

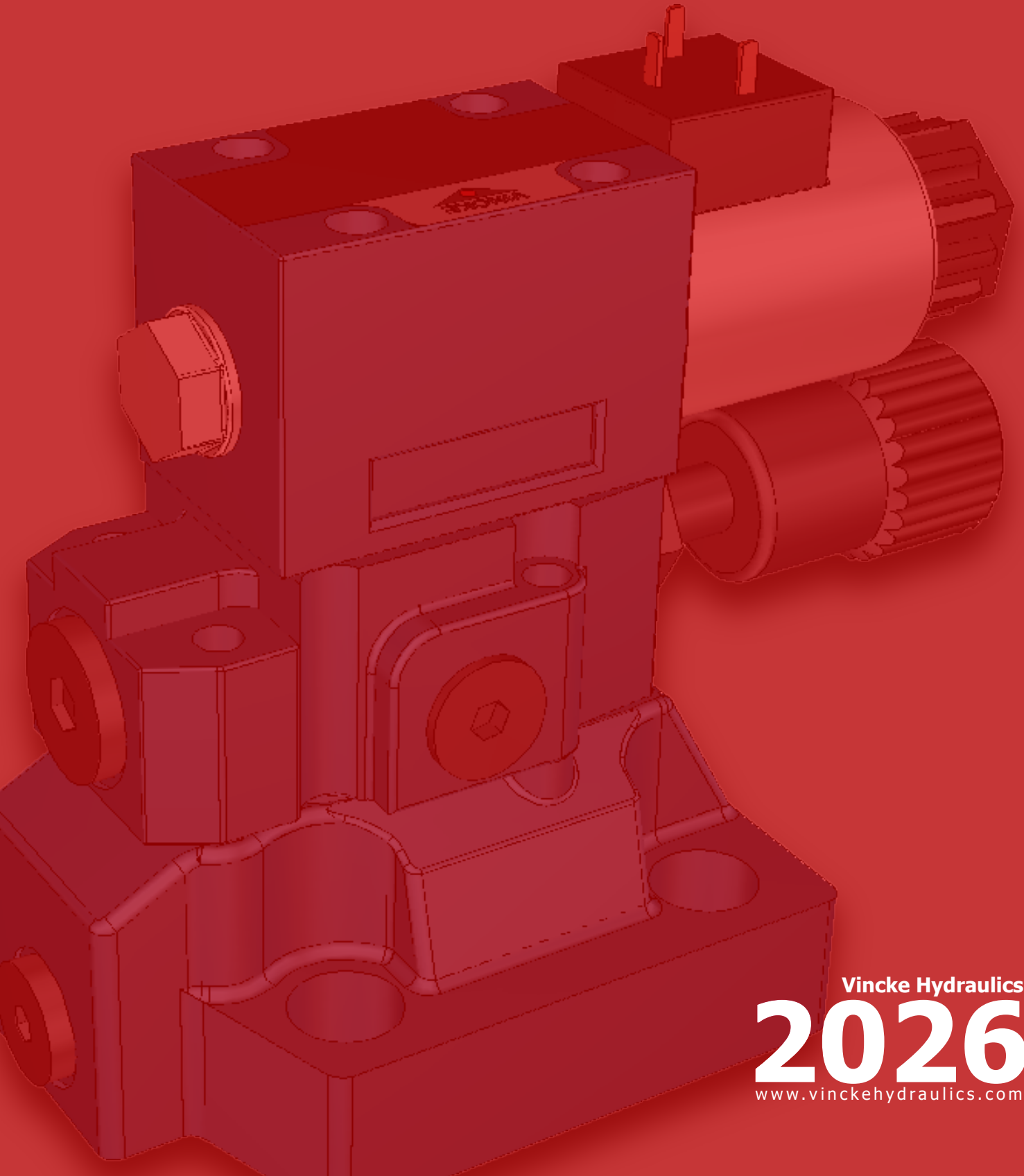

CETOP

Valves



Vincke Hydraulics
2026
www.vinckehydraulics.com



VINCKE
HYDRAULICS

01 VINCKE CETOP
SOLENOIDS

02 VINCKE CETOP
MODULARS VALVES

03 VINCKE PRESSURE
CONTROL VALVES

**ELECTRICAL OPERATED DIRECTIONAL
CONTROL VALVE**

Pág 3

**SOLENOID VALVE WITH HAND
CONTROL**

Pág 12

PROPORTIONAL FLOW REGULATOR

Pág 15

PROPORTIONAL DIRECTIONAL VALVE

Pág 17

**ELECTRO-HYDRAULIC DIRECTIONAL
CONTROL VALVE**

Pág 29

CETOP COILS

Pág 36

MANUAL EMERGENCY POSITIONER

Pág 38

**MANUAL OPERATED DIRECTIONAL
CONTROL VALVE**

Pág 39

VINCKE
HYDRAULICS

Electrical operated directional control valve

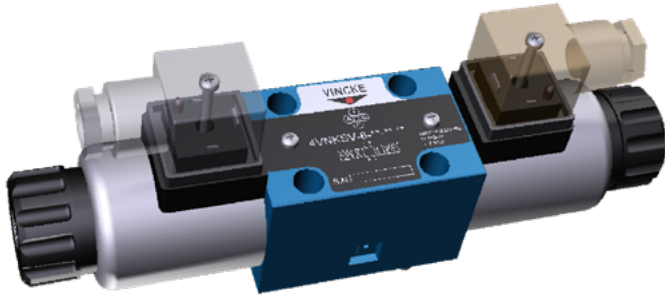

Vincke solenoid valves is designed and tested under innovative concepts to satisfy the advanced needs of currents machines: versatility, reduced power absorbed and safety of use.

Solenoid directional valves are used for changing flow direction in hydraulic systems.

Technical characteristics

Specification		06		10	
Working pressure (Mpa)	Oil ports P,A,B	35		31.5	
	Oil port T	16		16	
Max. Flow (L/min)		80		120	
Working fluid		Mineral oil: phosphate-ester			
Fluid temp. (°C)		-20~70			
Viscosity (mm ² /s)		2.8~100			
Working voltage (V)	DC	12		24	
	AC	110/50Hz		220/50Hz	
Max. Switch frequency (T/h)		15000 (DC)		7200 (AC)	
Insulation grade		IP65			
Weight (kg)	Single solenoid	1.45 (DC)	1.4 (AC)	5.1 (DC)	4.3 (AC)
	Double solenoid	1.95 (DC)	1.9 (AC)	6.7 (DC)	5.1 (AC)

Cleanliness

The maximum allowable cleanliness of the oil should be according to 9th degree of Standard Nas1638. It is suggested that the minimum filter rating should be $\beta_{10} \geq 75$.

Electrical operated directional control valve

Ordering Code

4VNKSV - 6 - E - OF - DC24 - 4L

4 main ports
 Nominal size 6 Cetop 3 or 10 Cetop 5
 Type of spool E, J, D, C, HA, E etc.
 With spring return = no code
 Without spring return = O
 Without spring return with detent = OF

Electrical Connection:
 4L= DIN connector+led
 4X= DIN connector without led
 DC 24 or DC12
 AC220 AC110 AC24

Code Symbol



1) Example:

Spool symbol H with spool A and coil side A, ordering code HA

Solenoid directional valves are used for changing flow direction in hydraulic systems.

Electrical operated directional control valve

Code symbol

4VNKSV-6

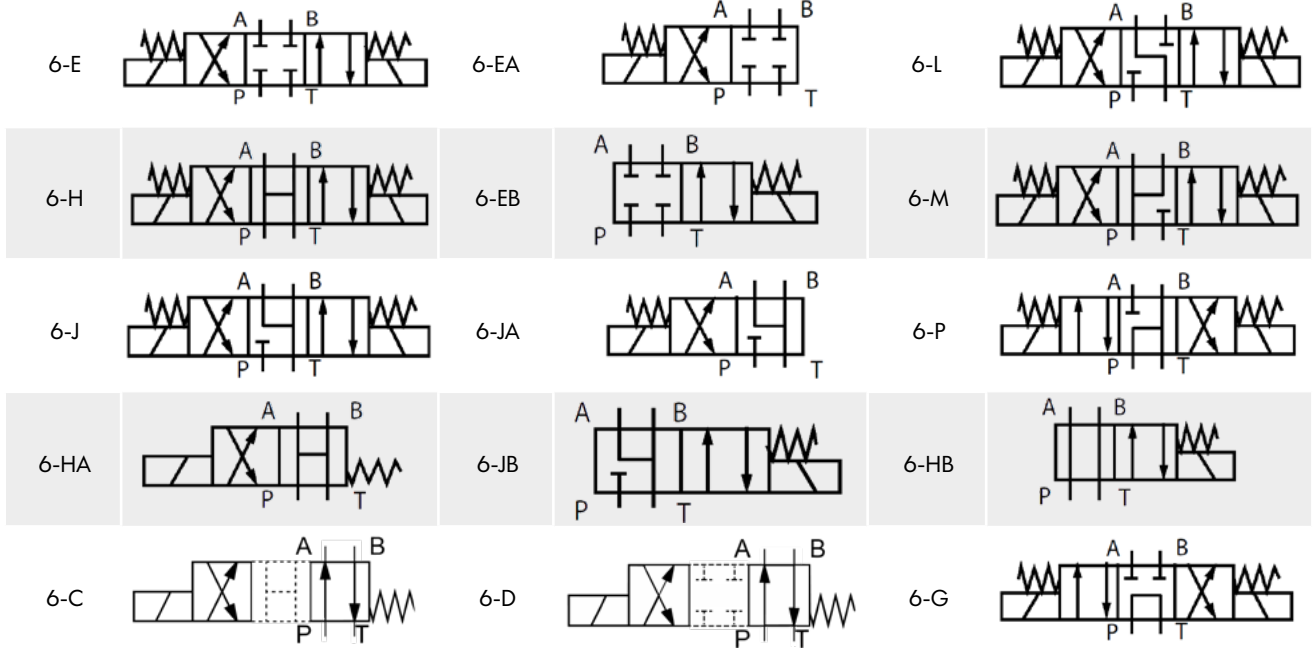

4VNKSV-10

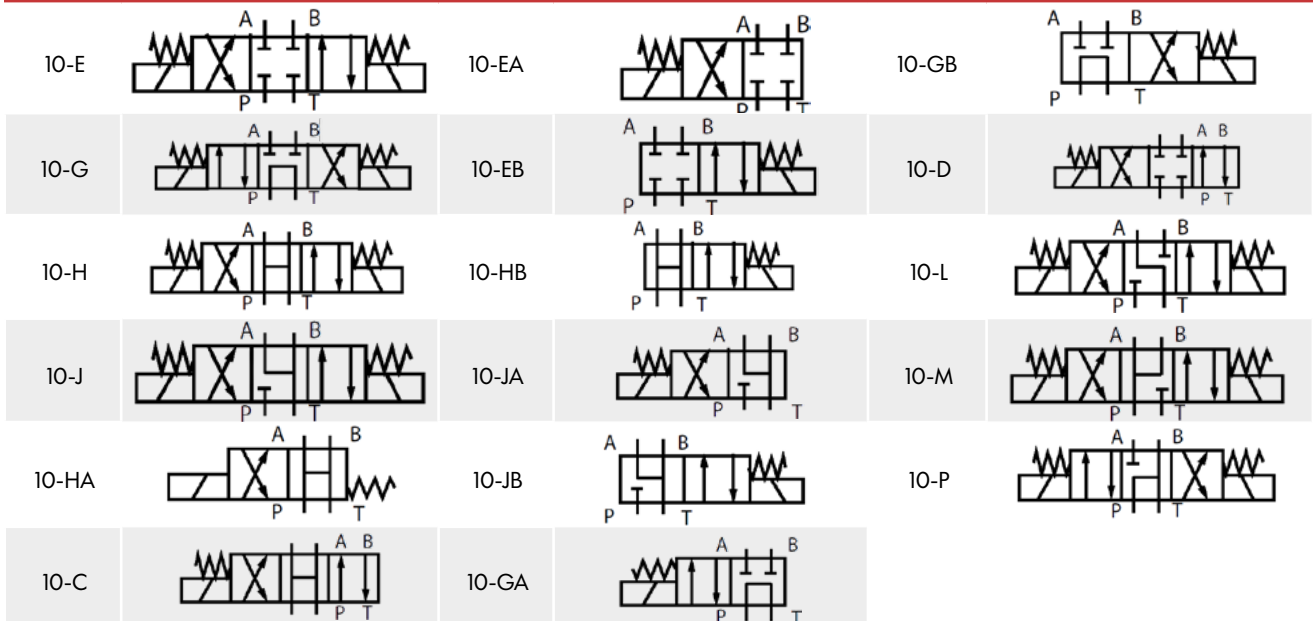

Electrical operated directional control valve

Cetop 3

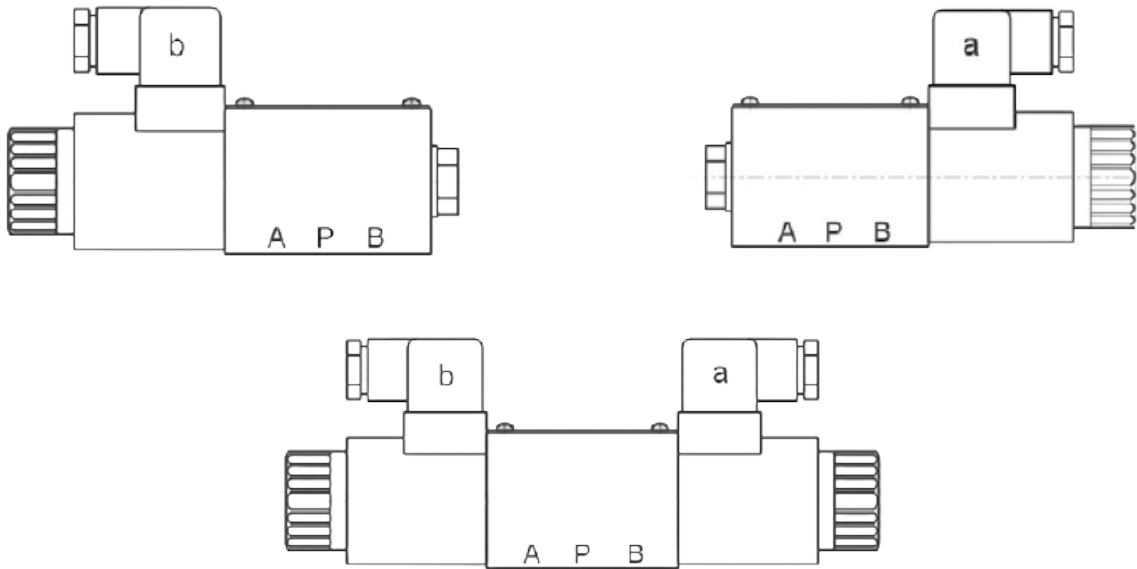

Specification Performance curve

Measured at $v=4\text{mm}^2/\text{s}$ and $t=50^\circ\text{C}$

Function Code	Direction			
	P > A	P > B	A > T	B > T
C	1	1	3	1
D	5	5	3	3
E	3	3	1	1
F	1	3	1	1
G	6	6	9	9
H	2	4	2	2
J	1	1	2	1
L	3	3	4	9
M	2	3	3	3
P	3	1	1	1

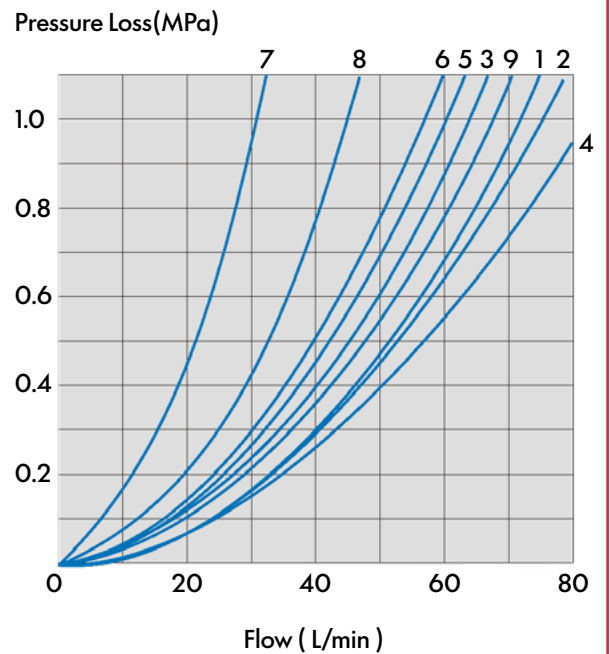

8. Spool symbol G in the neutral position P > T

Electrical operated directional control valve

Specification Working Limits

DC24 12 110		AC 220 110 24 50HZ	
Curve	Symbol	Curve	Symbol
4	F P	14	F M
5	J	15	G
6	G H	16	H
7	L	17	E H/OF E/OF J M L
8	C D	18	C D
9	M		
10	E H/OF E/OF		

With regard to the four-way valve, the normal flow data as show is get from the regular use of two directions of the flow. See tables. If only one flow direction is needed, the maximum flow may be very small in the serious condition.

Working pressure (MPa)

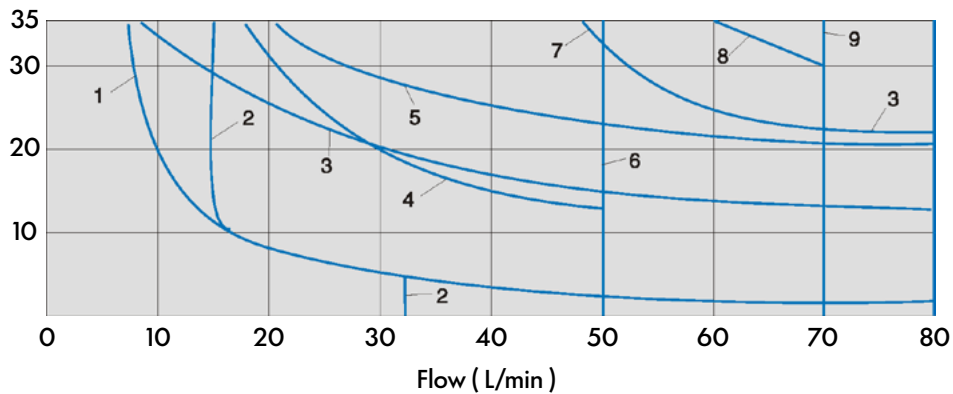

- 1) No manual emergency operation
- 2) Oil return from actuator to oli tank

Working pressure (MPa)

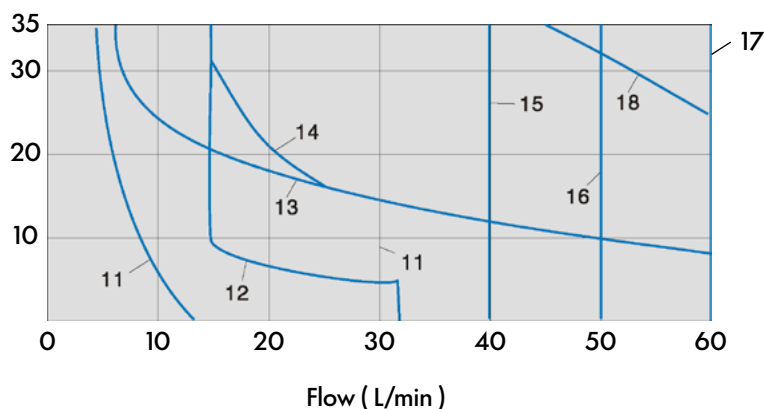

Electrical operated directional control valve

External Dimensions

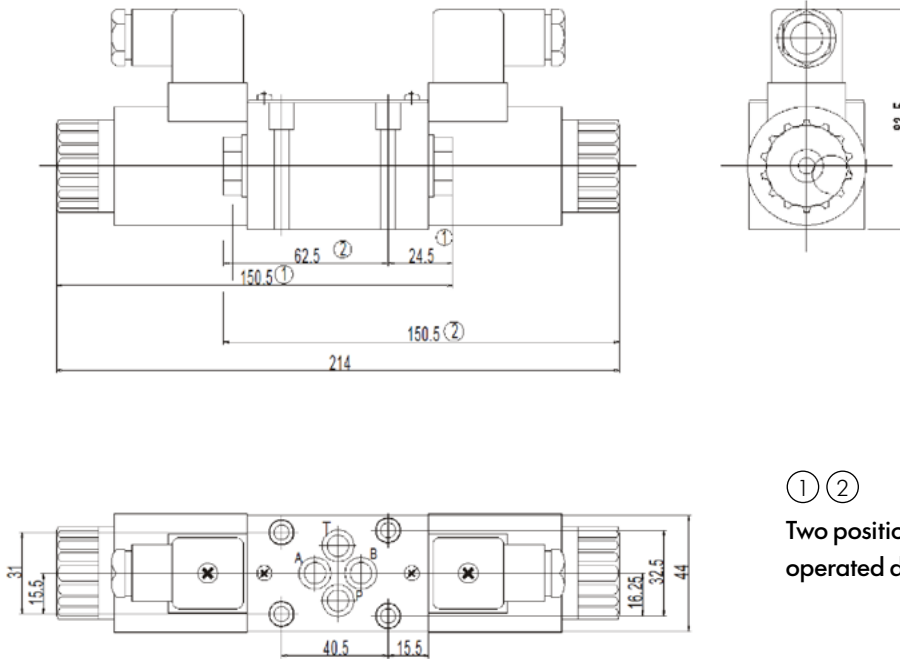

① ②

Two positions Electrical operated directional control valve

Size of Subplate Oil Port

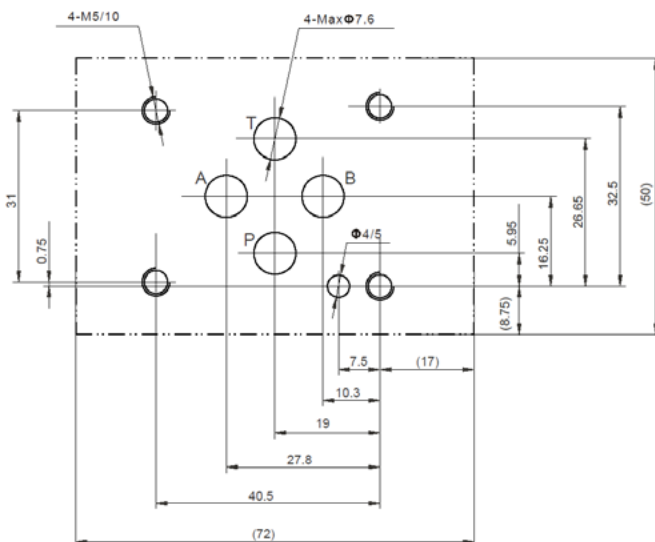

Mounting screw	Amount	Tighten torque
M5x45 - 10.9	4	9Nm

Supplementary explanation

1. When installing the product, considering horizontal position firstly.
2. The medium used in the hydraulic system must be filtered, its accuracy at least 20 μ m.
3. Screw should be according to the parameters in catalogue.
4. The surface, connecting with the valve, should be Ra0.8 roughness, and 0.01/100mm flatness.

Electrical operated directional control valve

Cetop 5

SPECIFICATION PERFORMANCE CURVE
Measured at $v=4\text{mm}^2/\text{s}$ and $t=50^\circ\text{C}$

Function Code	Direction			
	P > A	P > B	A > T	B > T
C D	2	2	3	3
E	2	2	4	4
F	2	3	3	5
G	3	3	4	6
H	1	1	4	5
L	1	1	4	5
M	1	1	5	1
P	3	2	5	3

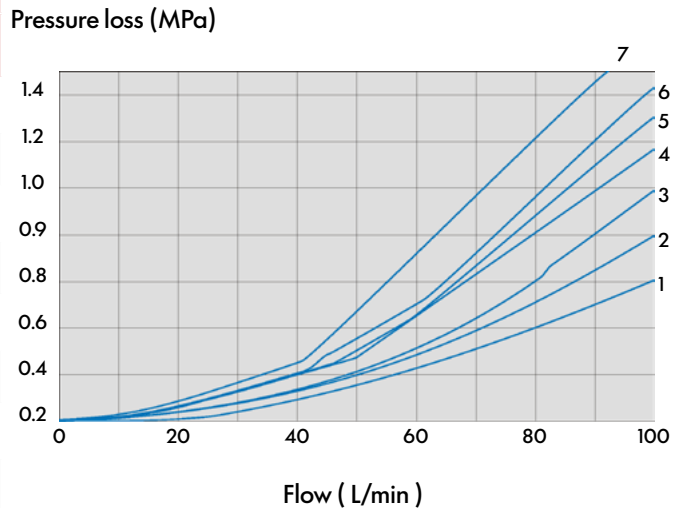

8. Spool symbol G in the neutral position P > T

Specification Working Limits

With regard to the four-way valve, the normal flow data as shown is get from the regular use of two directions of the flow (e.g. P to A, and simultaneous return flow from B to T). See tables, if only one flow direction is needed, for example: when a four port valve which is closed up port A or port B, used as a three-way valve, the maximum flow may be very small in the serious condition.

Working pressure (MPa) DC Solenoid operation

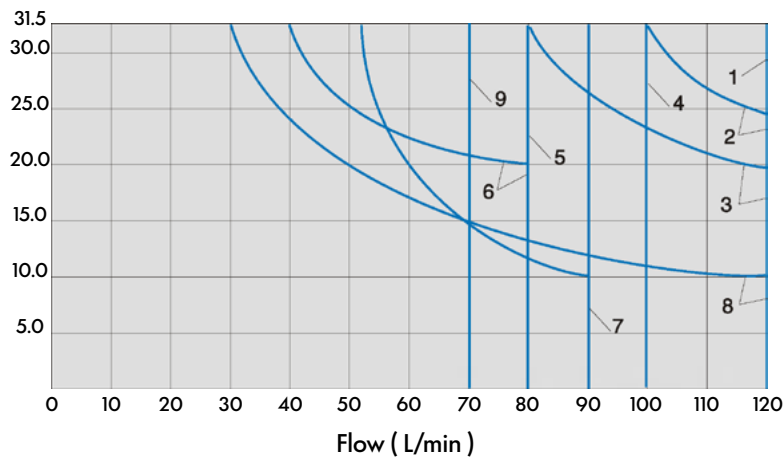

Curve	Symbol
1	C D H/OF E/OF M
2	E
4	L J H
6	G
7	F P

(1) Return circuit (independent of area ratio)

Electrical operated directional control valve

Working pressure (MPa) DC Solenoid operation

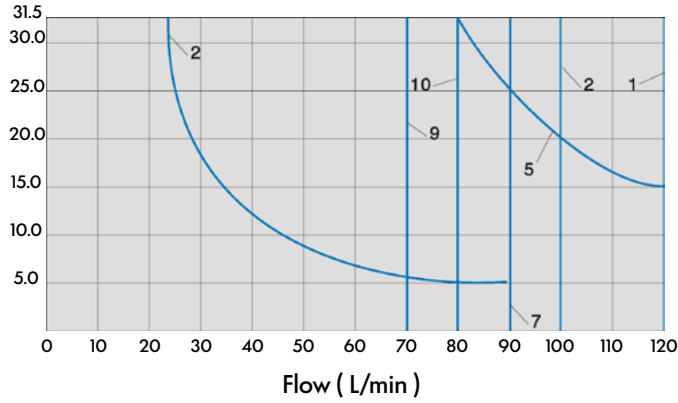

Working pressure (MPa) DC Solenoid operation

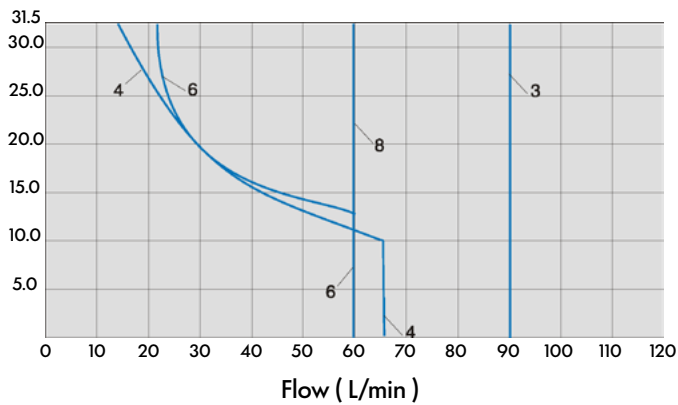

110V 220V	
Curve	Symbol
1	C D E/OF
2	E
3	L M
5	J
6	G
7	F P
8	H

External Dimensions

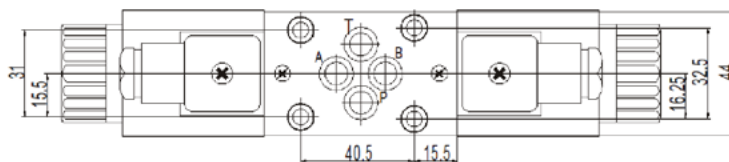
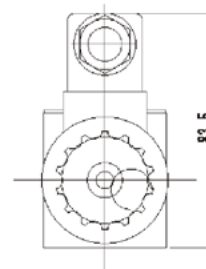
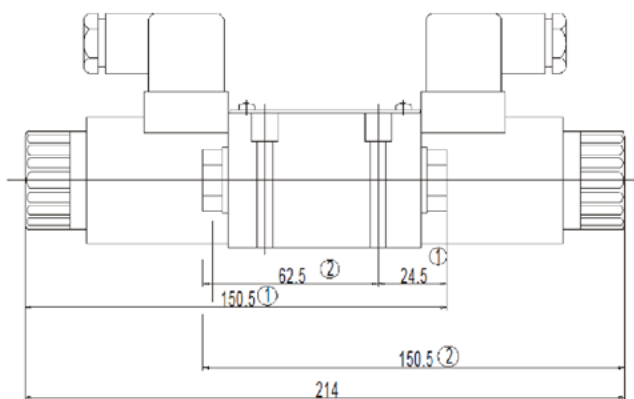

① ②

Two positions Electrical operated directional control valve

Electrical operated directional control valve

Size of Subplate Oil Port



Mounting screw	Amount	Tighten torque
M6x50 - 10.9	4	15Nm

Supplementary explanation

1. When installing the product, considering horizontal position firstly.
2. The medium used in the hydraulic system must be filtered, its accuracy at least $20 \mu\text{m}$.
3. Screw should be according to the parameters in catalogue.
4. The surface, connecting with the valve, should be Ra0.8 roughness, and 0.01/100mm flatness.

Solenoid Valve With Hand Control

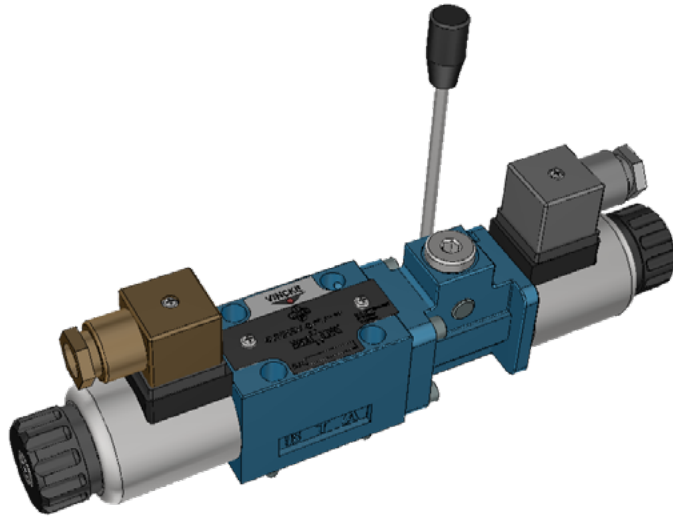

4VNKSV can work as standard solenoid directional valve.
Also can control the spool movement with hand level on power-off condition.

Technical Characteristics

Model		Cetop 3 / NG6	
Working pressure (Mpa)	Oil ports P,A,B	35	
	Oil port T	10	
Max. Flow rate (L/min)		80	
Installation		Any, recommended horizontal oil	
Working Fluid		Mineral hydraulic oil; phosphate ester hydraulic oil	
Fluid temp. (°C)		-20~70	
Fluid Viscosity (mm ² /s)		2.8~100	
Working voltage (V)	DC	12-24	
	AC	110/50Hz	
Max. Switch frequency (T/h)		15000 (DC)	7200 (AC)
	Protection grade	IP65	

Cleanliness

NAS1638 Class 9, recommended filtration precision Min $\beta_{10} \geq 75$.

Solenoid Valve With Hand Control

Ordering Code

4VNKSV - 6 - *HL - DC24 - 4L - * - * - *

Solenoid valve with hand control

Nominal size 6 Cetop 3

Spool type CHL, EHL, LHL etc.

DC 24 or 12 DC
AC220 AC110

Z5L Dinconnector with LED

Seal material
omit NBR
V FPM

Omit without damping
08 ø0.8 Damping
10 ø1.0 Damping
12 ø1.2 Damping

Omit with concealed
emergency push rod

Code Symbol

4VNKSV-6-*HL

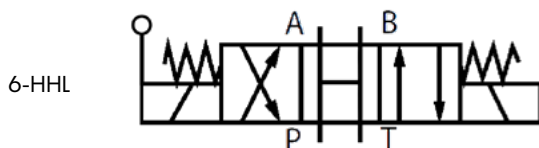
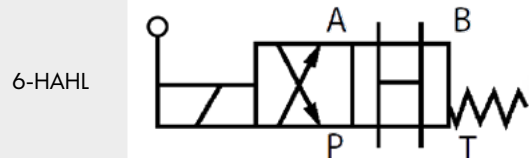
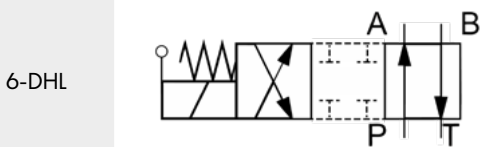
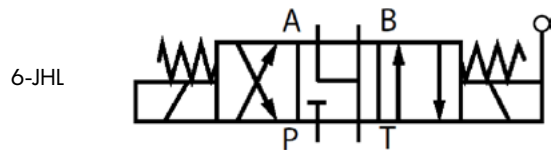
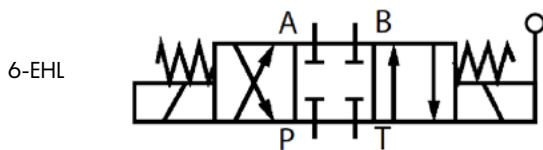

Solenoid Valve With Hand Control

External Dimensions

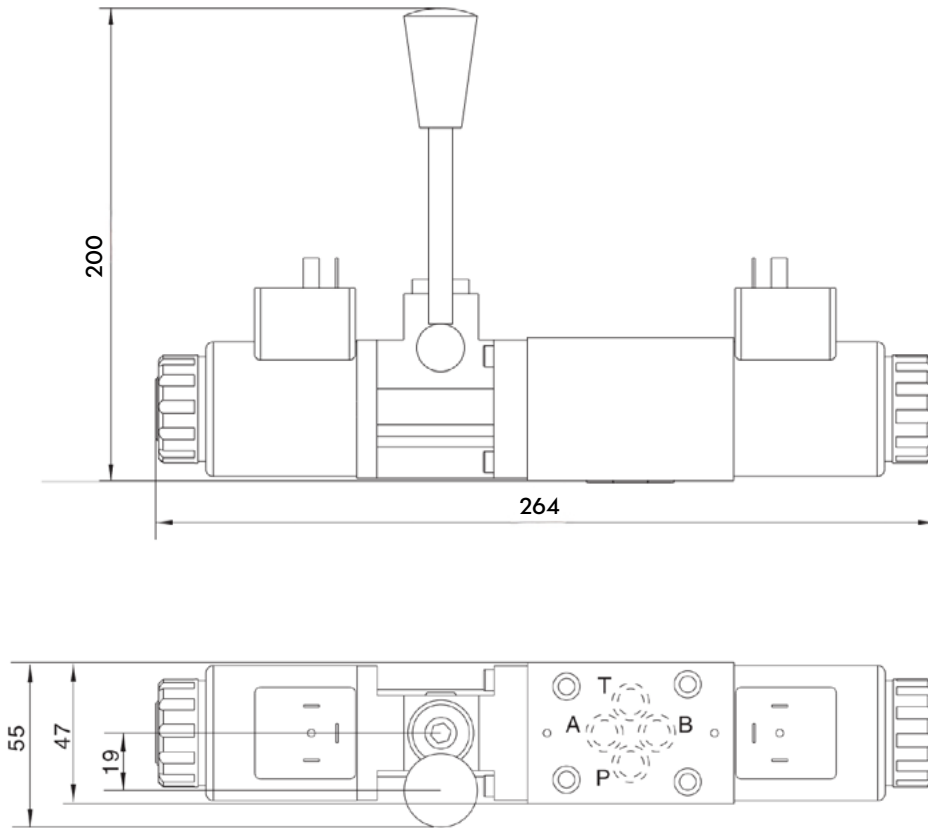

Size of Subplate Oil Port

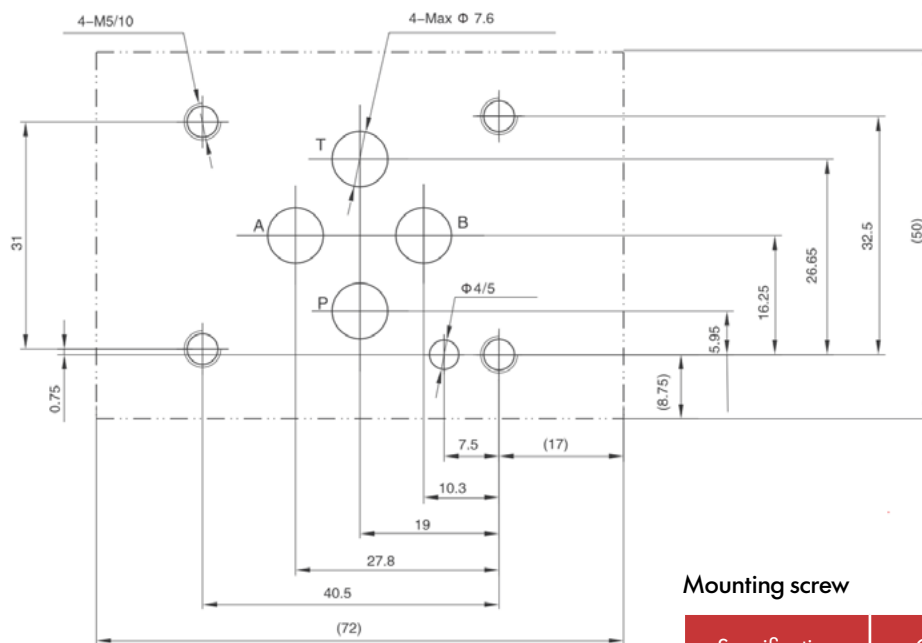

Mounting screw

Specification	Qty	Torque
M5x45 - 10.9	4	9Nm

Proportional Flow Regulator

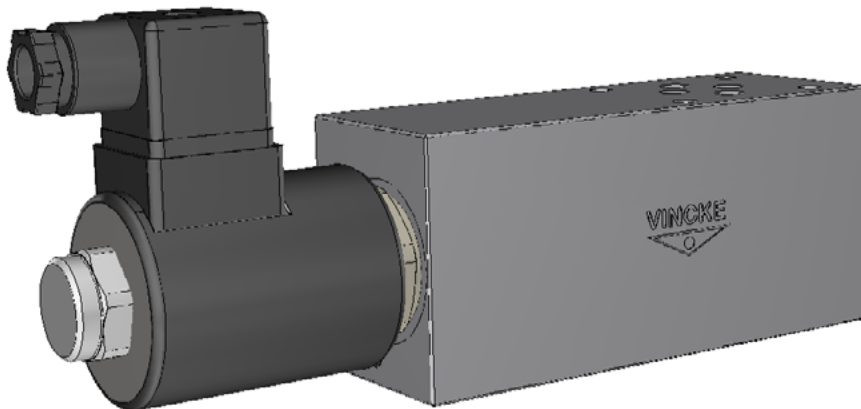

Technical Characteristics

Model	Cetop 3 / NG6
Flow Range:	See curves for various versions
Max. System Pressure:	241 bar
Leakage:	250 cc/min @ 207 bar
Hysteresis:	±5
Viscosity Range:	3 to 647 cSt
Filtration:	ISO 18/16/13
Media Operating Temp. Range	-30°C +100°C
Weight:	34Kg
Operating Fluid Media:	General Purpose Hydraulic Fluid
Cartridge Torque Requirements	50Nm
Coil Nut Torque Requirements	3-4Nm
External surfaces:	Zinc plated / zincate
Standard seals:	NBR 70 Shore A

Proportional Flow Regulator

Hydraulic Symbol

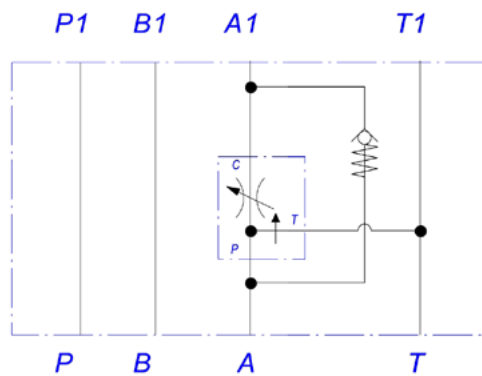

External Dimensions

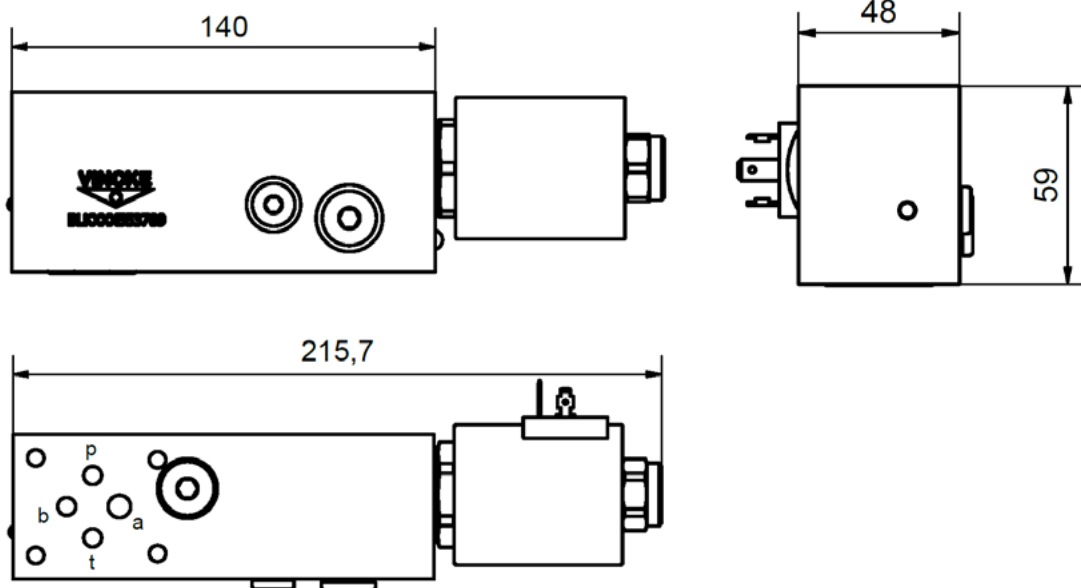

Proportional directional valve

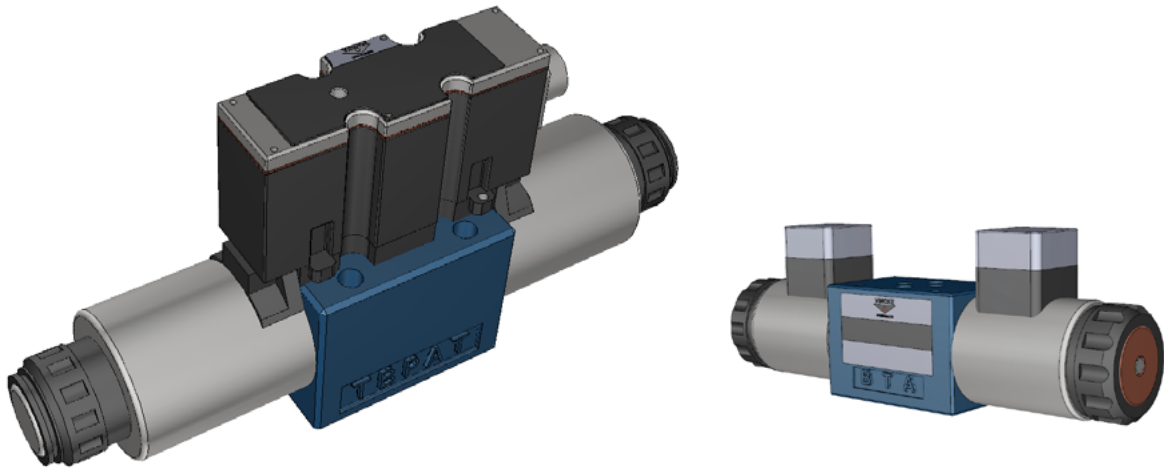

Technical Specification

Model	4VNKPV	4VNKPV-IE
Installing position	Optional, preferably horizontal	
Storage temperature range (°C)	-20~80	
Ambient temperature range (°C)	-20~70	-20~50

Hydraulic

	4VNKPV	4VNKPV-IE
Operating pressure (bar)	Ports A, B, P	315
	Port T	210
Nominal flow When q_{nom} at $\Delta p=10$ bar (L/min)	DN6	7, 17 and 30
	DN10	30, 60
Flow (Max. Permissible) (L/min)	DN6	42 (with double flow) 80
	DN10	75 (with double flow) 140
Pressure fluid	Mineral Oil (HL, HLP) to DIN 51 524; For other fluid please consult with us	
Fluid temp. Range (°C)	-20~80 (+40-+50 is preference)	
Viscosity range (mm ² /s)	-20~380 (30 ~ 46 is preference)	
Hysteresis (%)	≤5	
Reversal error (%)	≤1	
Response sensitivity (%)	≤0.5	

Cleanliness

Maximum permissible degree of pressure fluid contamination to NAS 1683 to class 9 Recommended filter $\beta_{10} \geq 75$.

Proportional directional valve

Electrical

Model		4VNKPV	4VNKPV-IE
Voltage type		Direct Voltage	
BFWN Command signal	Voltage input "A1" (V)	±10	±10
	Current Input "F1" (mA)	4~20	4~20
Max. current per solenoid (A)		2.5	2.5
Solenoid coil Resistance (Ω)	Cold value at 20 °C	6DN2	10DN2
	Max. Warm value	6DN3	10DN3
Duty Cycle (%)		100	
Max. Coil temperature ²⁾ (°C)		up to 150	
Hysteresis (%)		≤5	
Electrical connection		socket as per DIN EN 175 301-803 and ISO 4400 with component plug to DIN EN 175301-803 and ISO 4400	socket as per DIN EN 43 563-AM6-3 with component plug to DIN 43 563-BF6-3/ Pg11
Insulation of valve to DIN 40 050		IP 65	

Control Electronics

4VNKPV (type)	Analogue amplifier in Eurocard format ³⁾	Details refer to proportional amplifier	
	Digital amplifier in Eurocard format ³⁾	Details refer to proportional amplifier	
4VNKPV-IE (type)	Analogue command value module	Integrated into the valves	
Supply voltage	Nominal voltage	VDC	24
	4VNKPV-IE	V	21/22
	4VNKPV ¹⁾	V	35
Amplifier current consumption	/ _{max}	A	1.8
	Max. impulse current	A	3

1) With HOYEA control amplifier. 2) Due to the occurring surface temperature of the solenoid coils, the European Standards DIN EN 563 and DIN EN 982. 3) separate order.

Proportional directional valve

Ordering Code

4VNKPV-IE-6-***-24DC-***

Proportional directional valve (4VNKPV/-IE)

No code Without integrated electronics
IE With integrated electronics

Nominal size 6 Cetop 3, 10 Cetop 5

Spool symbols

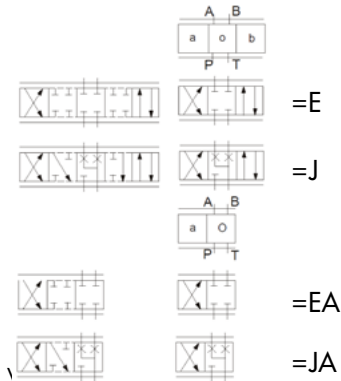

Note:
With spools 3C40 and 2B40B, in the neutral position, there is a connection from A to T and B to T with approx. 3 % of the relevant nominal cross section.

1. Other types of electrical protection on request
2. Only for DN6 for version 3C40 see a water resistant only state K 31 !

Further details in clear text

Nitrile rubber sealing
Omit
V NBR seals suitable for mineral oil (HL, HLP) to DIN 51 524

No code 4VNKPV(type)
4VNKPV-IE(type)
A1 Command value input $\pm 10V$
F1 Command value input 4~20mA

Electrical connection For
4VNKPV(type)
²K4 with plug component DIN EN 175301-803 see page A.1.3
4VNKPV-IE(type)
²K31 with plug component DIN 43 650-AM2 See page A.1.4

Special protection
No code Without special protection
¹J Seawater resistant (only for DN6)

24V 24VDC

2X Component series 20 to 29
(20 to 29 unchanged installation and connection dimensions)

Nominal flow at valve pressure differential $\cdot P = 10$ bar

07	DN 6
17	7 L/min
30	17 L/min
30	30 L/min
60	DN 10
60	30 L/min
60	60 L/min

Model Description

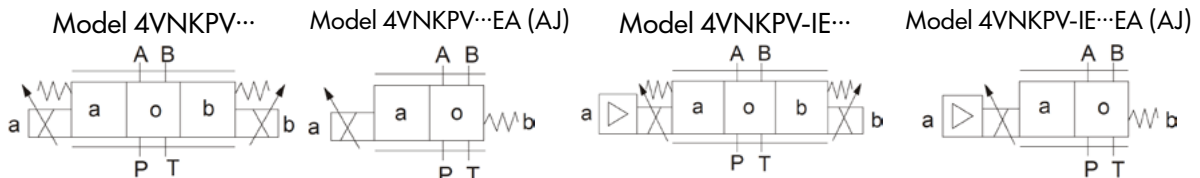

Proportional directional valve

Structure and Function Description, Section

The 4/2-way and 4/3-way proportional directional valves are designed as direct operated components for subplate mounting. They are actuated by means of proportional solenoid with central removable coil. The solenoids are controlled either by external control electronics (type 4VNKPV) or integrated control electronics (type VNKPV-IE).

Design:

The valves basically consist of:

- Body (1) with mounting surface
- Control spool (2) with compression springs (3 and 4)
- Solenoids (5 and 6) with central coil
- Optional integrated electronics (7)

Function:

-When solenoids (5 and 6) do not work, the control spool (2) is held in the central position by compression springs (3 and 4)

-Direct actuation of the control spool (2) by energising a proportional solenoid E.g. When the solenoid "b" power is on (6)

-The control spool (2) is moved to the left in proportion to the electrical input signal

-connection from P to A and B to T via orifice-like cross-sections with progressive flow characteristics

-When the solenoid power is off (6)

-The control spool (2) is returned to the central position by compression spring (3)

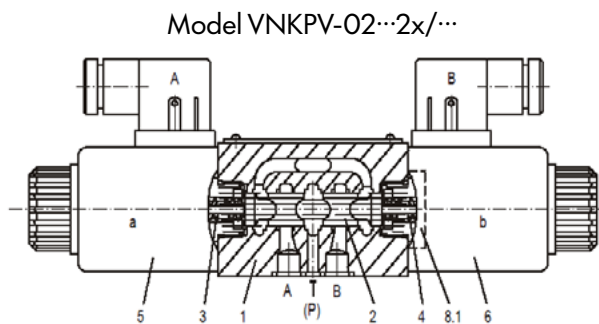

In theory, the function of this valve is the same to the valve with 3 positions. However, the valves with 2 positions are only fitted with solenoid "a".

For DN6 valve, there is a plug (8.1) fixed in the second solenoid, but for DN10, it is a cover (8.2) instead.

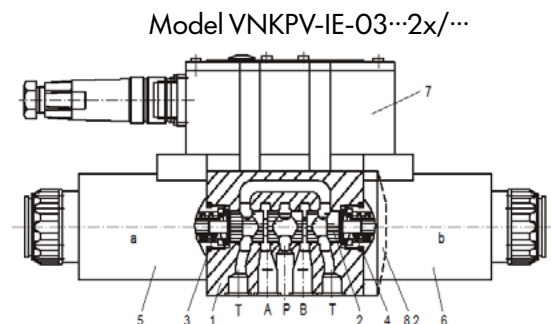

Note for type VNKPV-02 2X/ :

Draining of tank line is to be avoided.

With the appropriate installation conditions, a back pressure valve is to be installed (back pressure approx. 2 bar).

Proportional directional valve

Electrical Connection, Plug-in Connectors

VNKPV type (Without integrated electronics not for version "J" = sea water-resistant)

Connection on component plug

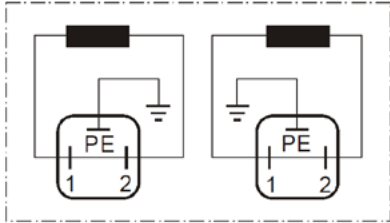

Connection on plug-in connector

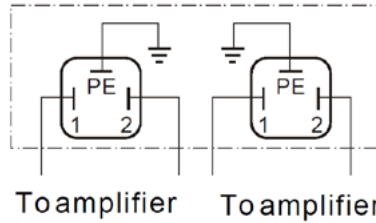

Plug-in connector: CECC 75
301-803-A002FAH3D08-
G/DIN EN 175 301-803 and ISO 4400

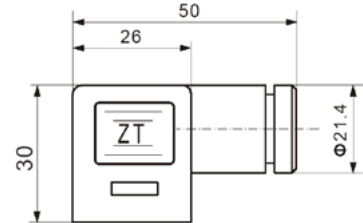

For type VNKPV-IE (with integrated electronics (OBE) and for version "J" = sea water-resistant) Plug-in connector see the block circuit diagram below

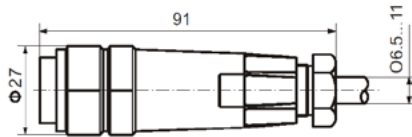

Plug-in connector:
DIN 43 563-BF6-3/Pg11

Integrated electronics for type VNKPV-IE

Pin allocation of the component plug

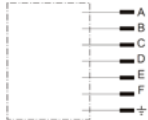

	Contact	Signal
Supply voltage	A	24DC (19~35DC)
	B	GND
	C	n.c. ⁽¹⁾
Differential amplifier input	D	Com. value ($\pm 10V/4-20mA$)
	E	reference potential
	F	n.c. ⁽¹⁾

Com. value: Positive command value (0 to 10 V or 12 to

20 mA) at D and reference potential to E causes flow from P to A and B to T.

Negative command value (0 to 10 V or 12 to 4 mA) at D and reference potential to E causes flow from P to B and A to T.

For valves with a solenoid on side a (spool variants 2B2B and 2B40B) a positive command value at D and reference potential to E (NS 6: 4 to 20 mA and NS 10: 12 to 20 mA) causes flow from P to B and A to T.

Recommendation:

-up to 25m cable length type LiYCY 5 x 0.75 mm²

-up to 50 m cable length type LiYCY 5 x 1.0 mm²

External diameter 6.5 to 11 mm

Connect screen to PE only on the supply side

Proportional directional valve

Block Circuit Diagram / Connection Allocation

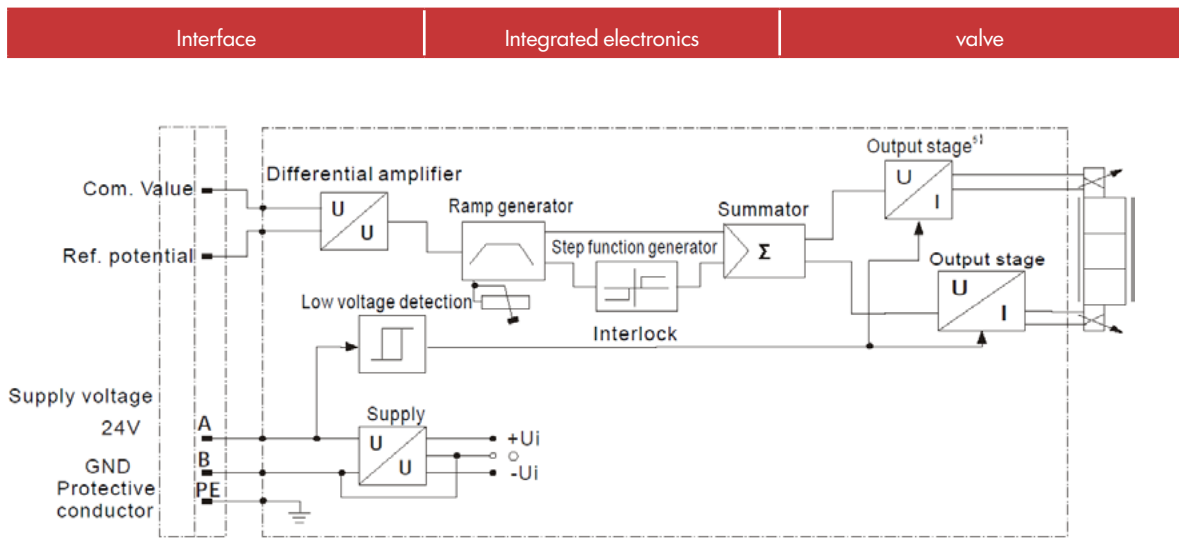

- 1) Contacts C and F must not be connected!
- 2) PE is connected to the cooling body and the valve housing
- 3) Protective conductor screwed to the valve housing and cover
- 4) Ramp be externally adjusted from 0 to 2.5s; the same applies for T_{up} and T_{down}
- 5) Output stages current regulated
- 6) Low voltage detection is not carried out for component type 4VNKPV-IE-03-2X

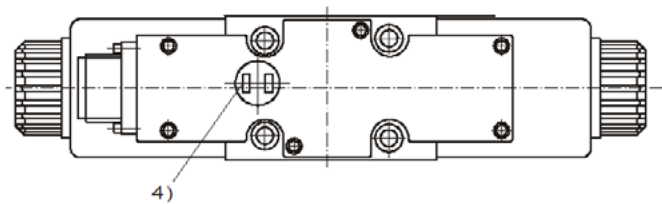

Proportional directional valve

Characteristic Curves

Cetop 3 / NG6

Transient functions with stepped form of electrical input signal

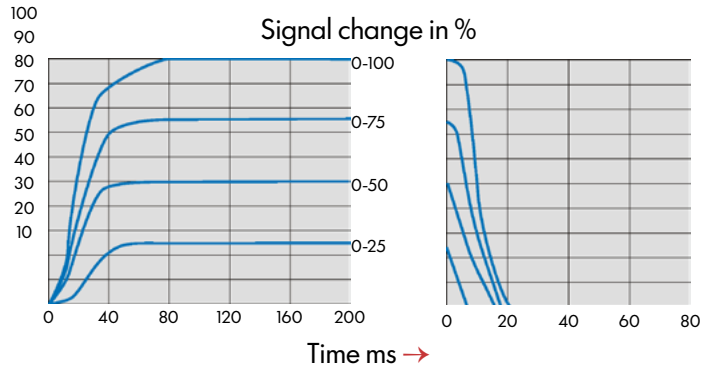

Performance limit, nominal flow 7 L/min

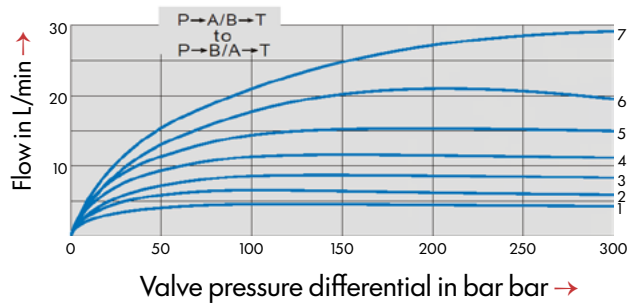

Performance limit, nominal flow 17 L/min

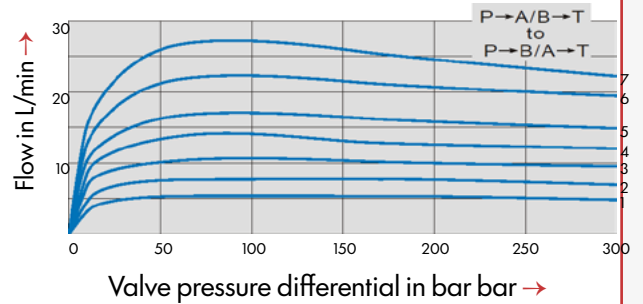

Performance limit, nominal flow 30 L/min

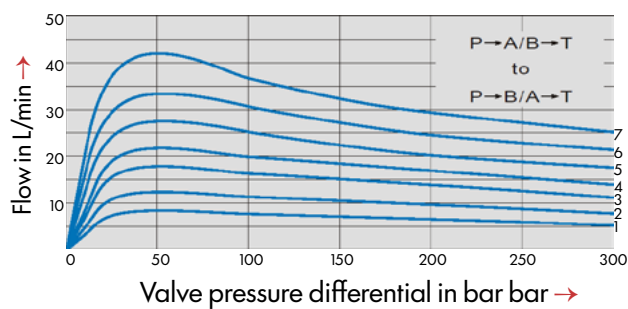

1. Com. Value=40%
2. Com. Value=50%
3. Com. Value=60%
4. Com. Value=70%
5. Com. Value=80%
6. Com. Value=90%
7. Com. Value=100%

If the performance limits are exceeded, then the movement of spool will be unstable

Proportional directional valve

Cetop 5 / NG10

Transient functions with stepped form of electrical input signal

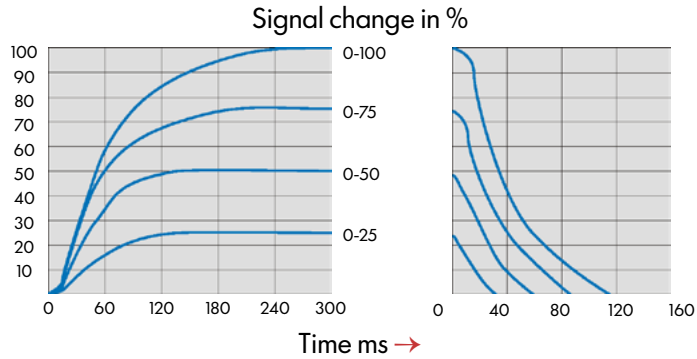

Performance limit, nominal flow 30 L/min

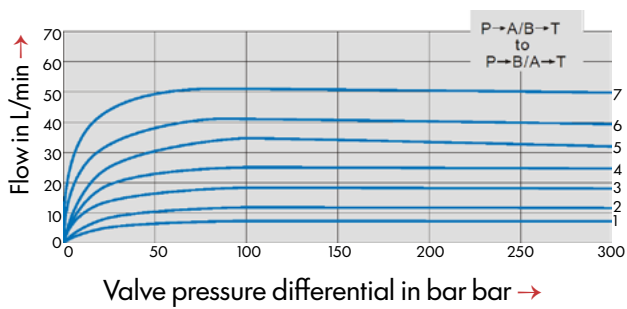

Performance limit, nominal flow 0 L/min

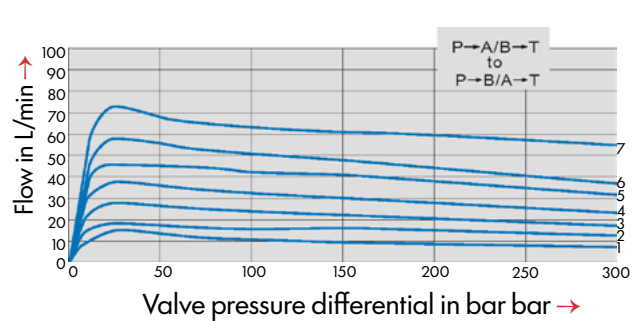

1. Com. Value=40%
2. Com. Value=50%
3. Com. Value=60%
4. Com. Value=70%
5. Com. Value=80%
6. Com. Value=90%
7. Com. Value=100%

If the performance limits are exceeded, then the movement of spool will be unstable

Proportional directional valve

Characteristic Curves (measured with HLP46, Qoil = 40 ± 5°C) Cetop 3 / DN6

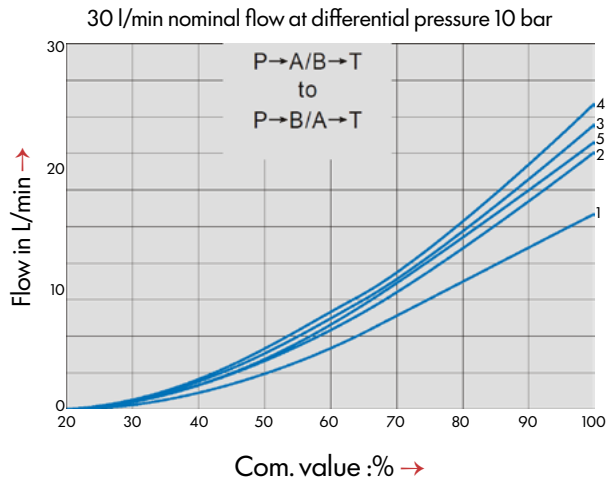
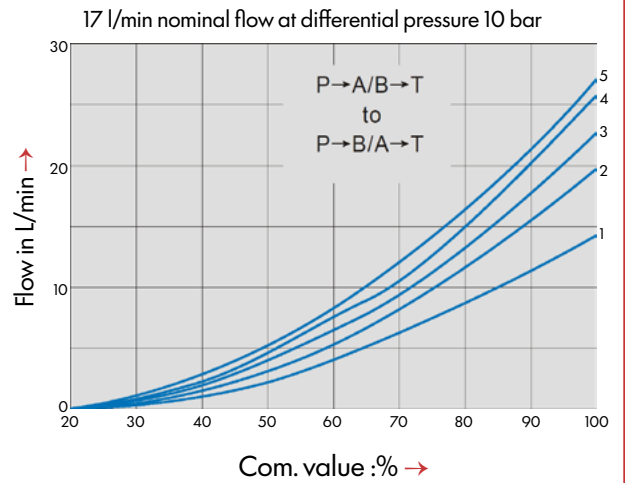
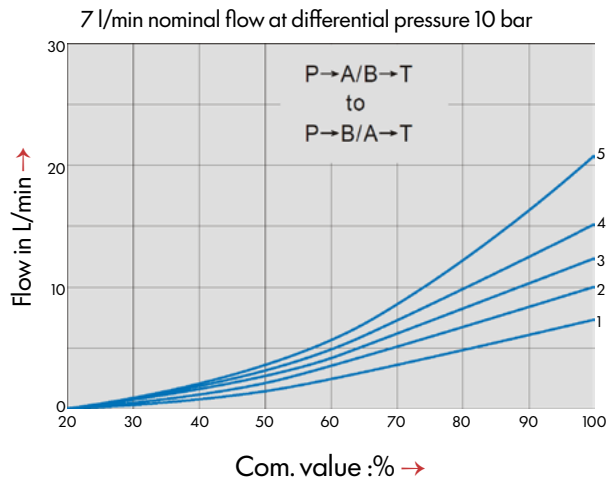

1. $\Delta p = 10 \text{ bar}$ Constant
2. $\Delta p = 20 \text{ bar}$ Constant
3. $\Delta p = 30 \text{ bar}$ Constant
4. $\Delta p = 50 \text{ bar}$ Constant
5. $\Delta p = 100 \text{ bar}$ Constant

Δp = Valve pressure differential
(inlet pressure P_p minus load pressure P_t and
minus return pressure P_r)

Proportional directional valve

Characteristic Curves (measured with HLP46, $Q_{oil} = 40 \pm 5^\circ C$) Cetop / DN10

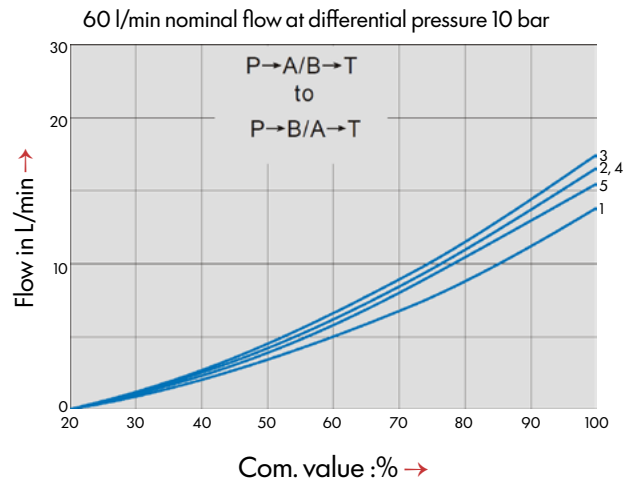
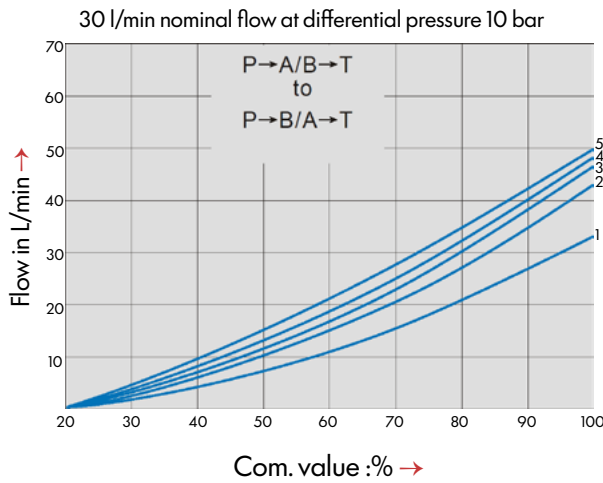

1. $\Delta p = 10$ bar Constant
2. $\Delta p = 20$ bar Constant
3. $\Delta p = 30$ bar Constant
4. $\Delta p = 50$ bar Constant
5. $\Delta p = 100$ bar Constant

Δp = Valve pressure differential
(inlet pressure P_p minus load pressure P_L and
minus return pressure P_r)

Unit Dimensions

Cetop 3 / NG6

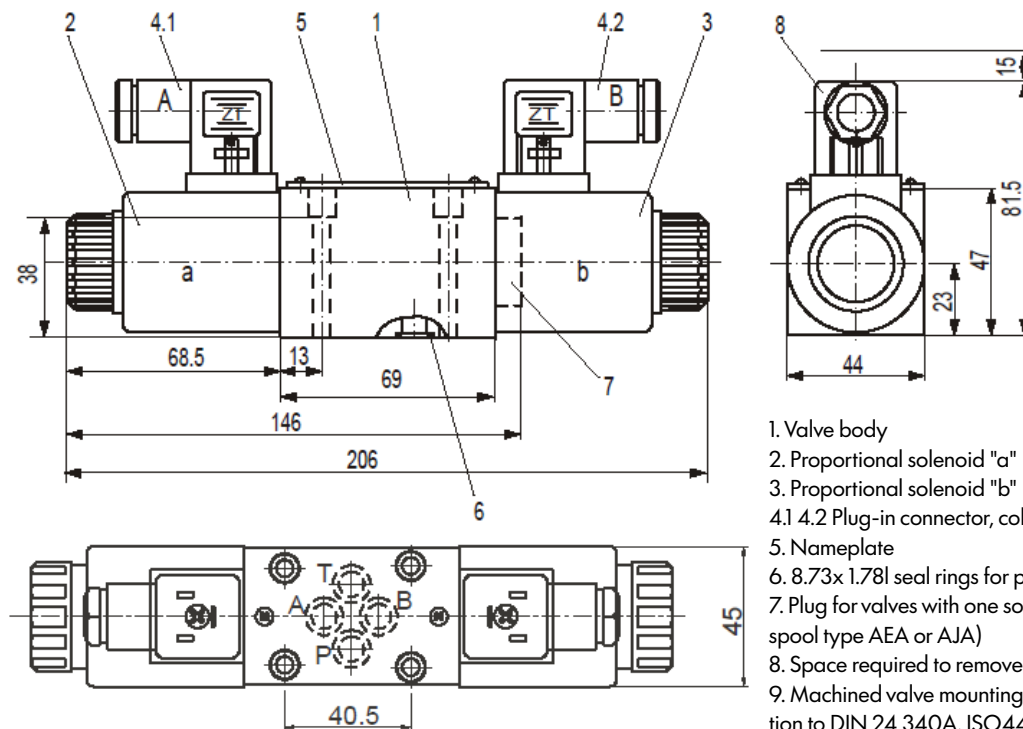

1. Valve body
2. Proportional solenoid "a"
3. Proportional solenoid "b"
- 4.1 4.2 Plug-in connector, colour black, separate order
5. Nameplate
6. 8.73x 1.78l seal rings for ports A, B, P and T
7. Plug for valves with one solenoid (2 positions
spool type AEA or AJA)
8. Space required to remove the plug-in connector
9. Machined valve mounting surface, connection location
to DIN 24 340A, ISO4401 (and) CETOP-RP 121H

Proportional directional valve

Cetop 3 / NG6

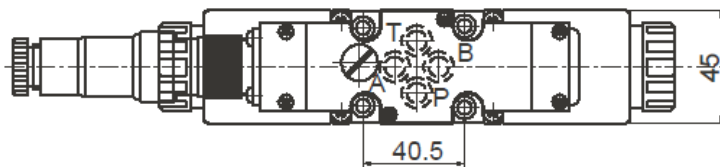
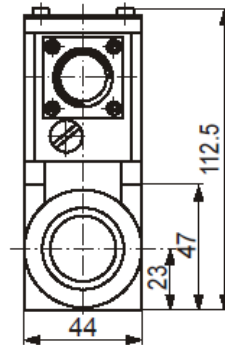
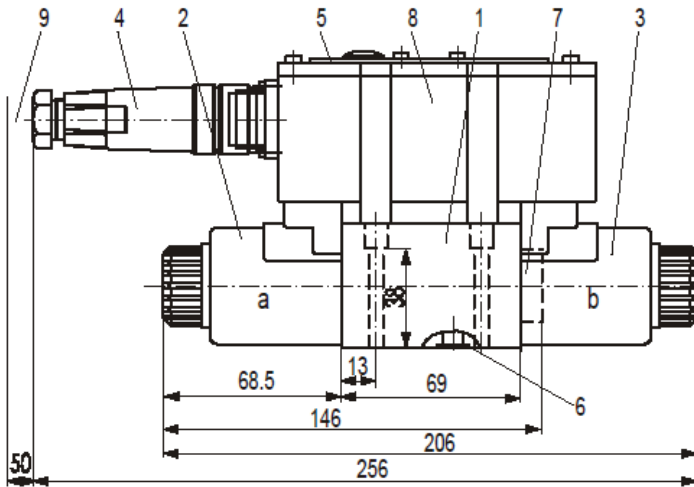

1. Valve body
2. Proportional solenoid "a"
3. Proportional solenoid "b"
4. Plug-in connector to E DIN 43 563-BF6-3/Pg11
5. Nameplate
6. 8.73x 1.78l identical seal rings for ports A, B, P and T
7. Plug for valves with one solenoid (2 switched positions pool type AEA or AJA)
8. integrated electronics
9. Space required for the connection cable and to remove the plug.in connector
9. Machined valve mounting surface, connection location DIN 24 340A, ISO440 and CETOP-RP 121H

Subplate Size

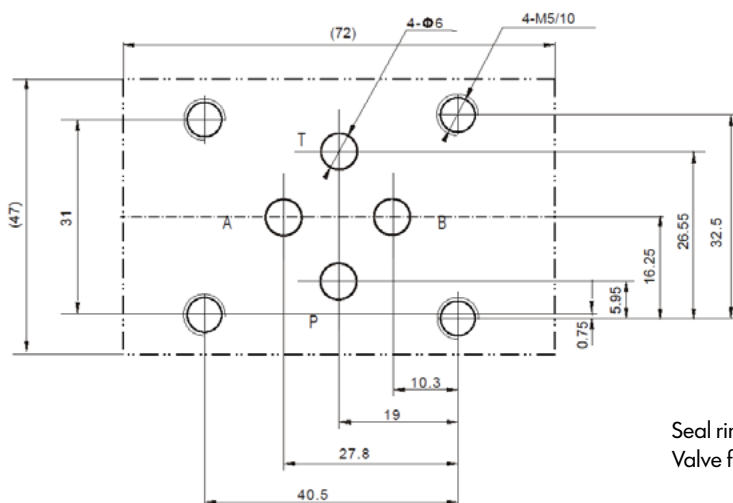

Seal ring: 8.73x1.78
 Valve fixing screw: 4-M5x45-12.9(GB70-85)

The surface, connecting with the valve, should be Ra0.8 roughness, and 0.01/100mm flatness.

Proportional directional valve

Cetop 5 / NG10

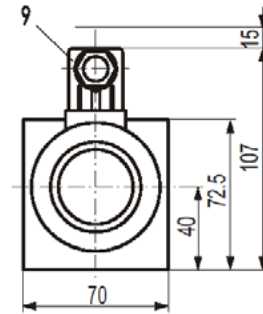
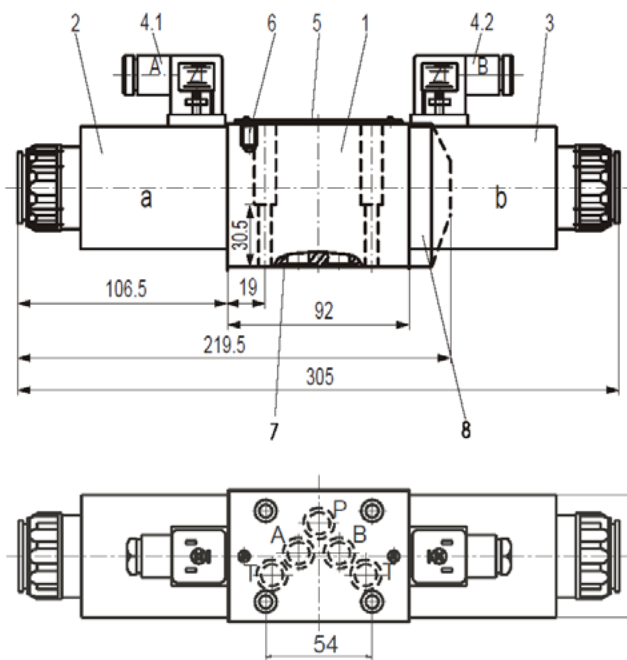

1. Valve body
2. Proportional solenoid "a"
3. Proportional solenoid "b"
- 4.1 4.2 Plug-in connector, colour black, separate order
5. Nameplate
6. Valve deflation screw
7. 12x 2 seal rings for ports A, B, P and T
8. Plug for valves with one solenoid (2 positions spool type AEA or AJA)
9. Space required to remove the plug-in connector
10. Machined valve mounting surface, connection location to DIN 24 340A, ISO4401 (and) CETOP-RP 121 H

Subplate Size

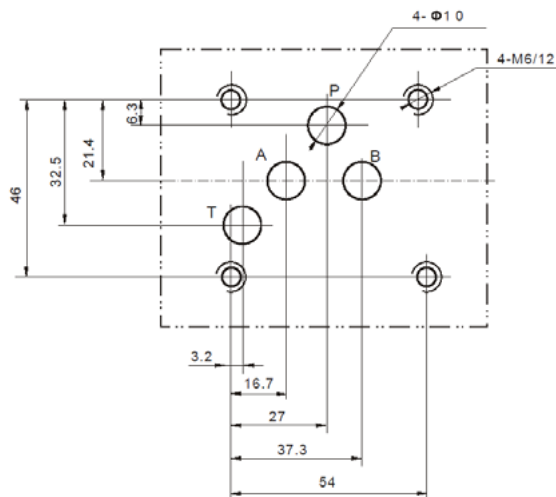

- Seal ring: 8.73x1.78
 Valve fixing screw: 4-M5x45-12.9(GB70-85)

The surface, connecting with the valve, should be Ra0.8 roughness, and 0.01/100mm flatness.

Electro-hydraulic directional control valve

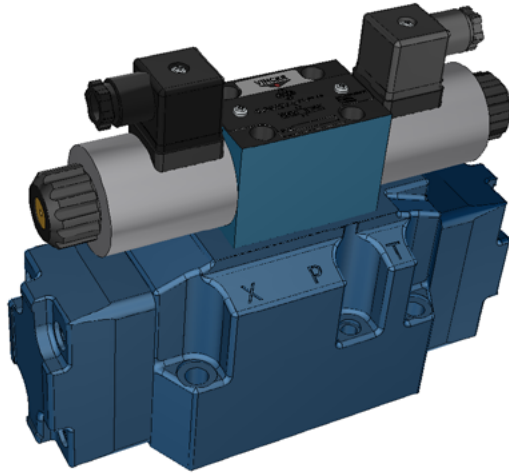

Technical Specification

Specification		Cetop 7 / NG16		Cetop 8 / NG25	
Model		4VNKEH-16	4VNKEH-16	4VNKEH-25	4VNKEH-25
	P, A, B Port		35		35
Max. Working (MPa) pressure	T port (internal leakage of control oil)		10		10
	Y port (external leakage of control oil)		10		10
Minimum control pressure (MPa)		1.2 Spring - Return 4/3 valve 4/2 valve		1.3 Spring - Return 4/3 valve 4/2 valve	
Maximum control pressure (MPa)		To25			
Max. Flow (L/min)		300		650	
Working fluid		Mineral oil: phosphate-ester			
Fluid temp. (°C)		-20~70			
Viscosity (mm ² /s)		2.8~380			

Cleanliness

The maximum allowable cleanliness of the oil should be according to 9th degree of Standard Nas 1638. It is suggested that the minimum filter rating should be $\beta_{10} \geq 75$.

Electro-hydraulic directional control valve

Ordering Code

4VNKEH-16-*-*-DC24V-*-*-*-*-*

Electro-hydraulic directional control valve

Nominal size 16 Cetop 7, 25 Cetop 8

Main valve return type
Omit Spring return
H Hydraulic centration

Function code
Details as following symbol table

Working voltage
D12 DC12V
D24 DC24V
A110 AC110V
A220 AC220V
B110 AC110V Rectified
B220 AC220 Rectified

Z5L Square connector with light
Z6 Wire box type

Omit without hand emergency
N9 with concealed hand emergency

Seal material
Omit NBR Seals
V FPM Seals

²⁾Omit No reducing valve
D3 With reducing valve

¹⁾Omit Without pre-load valve
P4.5 With pre-load valve

Omit without stroke adjusting device
A Head A of main valve with stroke adjustment
B Head B of main valve with stroke adjustment
W Both heads with stroke adjustment

Omit without shifting time adjustment
S With shifting time adjustment: Inlet flow control
S1 shifting time adjustment: Outlet flow control

Omit without damping
08 ø0.8 Damping
10 ø1.0 Damping
12 ø1.2 Damping

Omit Intl cntrl intl disch
XY Extl cntrl intl disch
X Extl cntrl intl disch
Y Intl cntrl intl disch

Explanation

- For neutral unloaded directional control valve it must be ordered separately. There is no model (4VNKEH) Electro-hydraulic directional control valve NS10.
- Only applied when the controlling pressure is higher than 25MPa

Code Symbol

4VNKSV-6-*HL

16-E
25-E

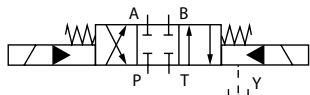

16-J
25-J

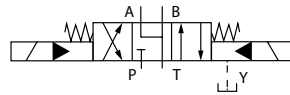

16-M
25-M

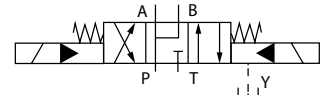

16-G
25-G

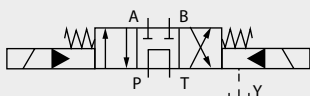

16-L
25-L

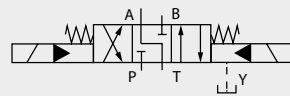

16-P
25-P

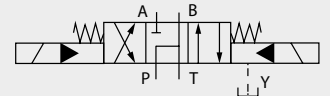

16-H
25-H

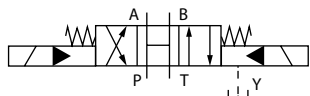

16-GA
25-GA

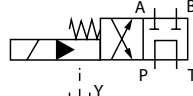

Electro-hydraulic directional control valve

Name of Solenoid

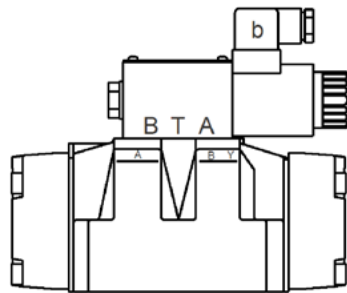
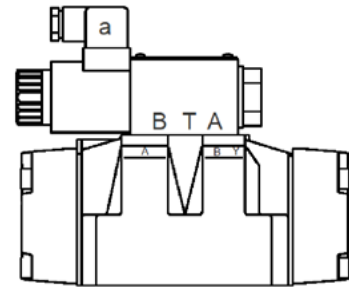
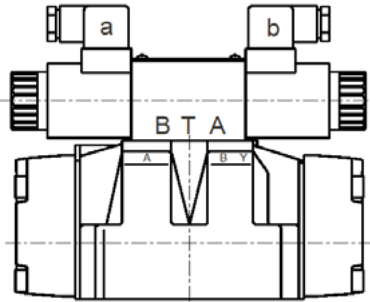

1. a When movement a, $P \rightarrow A$ $B \rightarrow T$
 2. b When movement b, $P \rightarrow B$ $A \rightarrow T$
 3. G Oil flow in the opposite direction with the above-mentioned movement.
- For E, when solenoid "a" works, $P \rightarrow A, B$

Electro-hydraulic directional control valve

Performance Curve

Cetop 7 / NG16

E

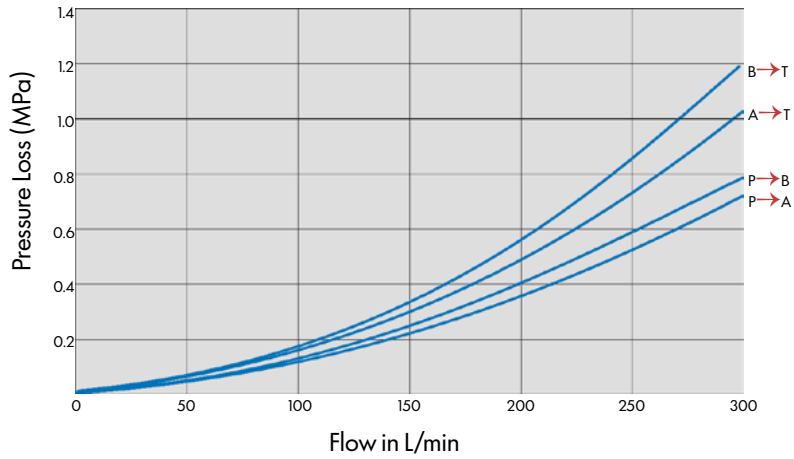

G

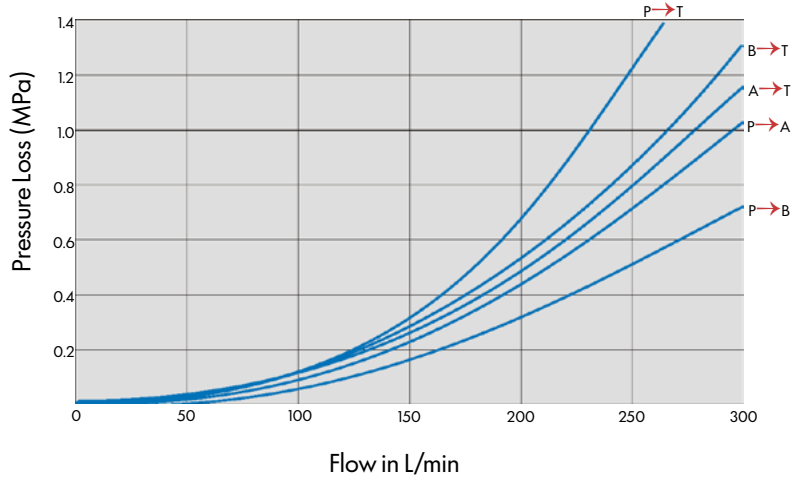

R

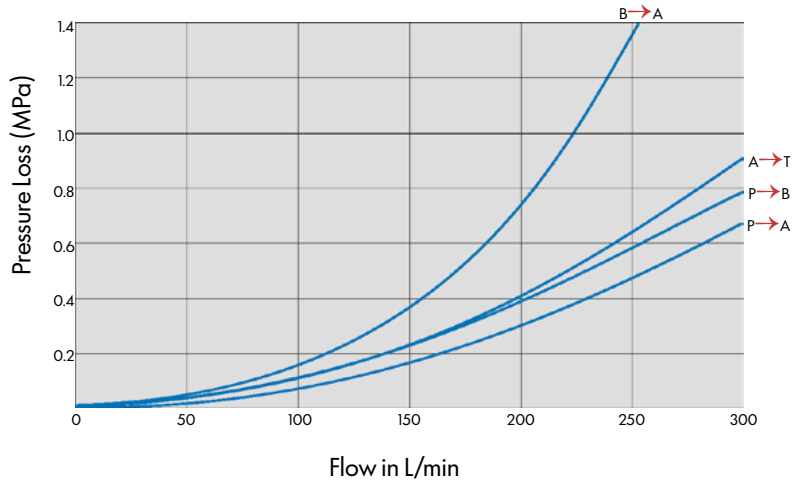

Electro-hydraulic directional control valve

Cetop 8 / NG25

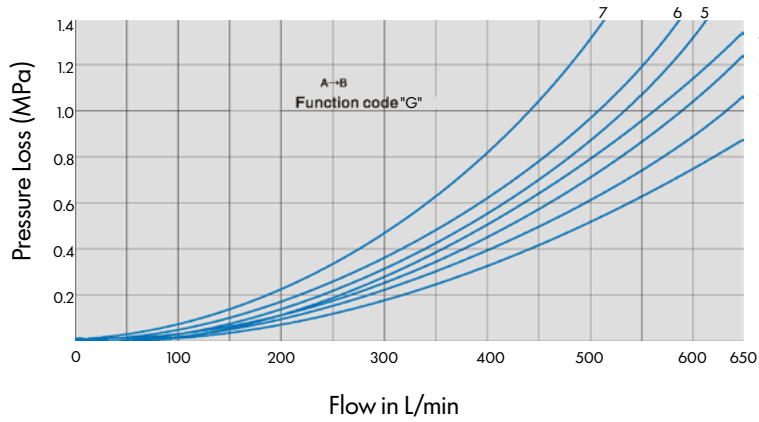

Function	Switching position			
	P→A	P→B	A→T	B→T
E	1	2	4	5
F	1	4	1	1
G	4	2	2	6
H	4	4	1	4
J	1	2	1	3
L	2	3	1	4
M	4	4	3	4
P	4	1	3	4
E	2	3	3	5
V	3	3	3	4

7. Function code "G" type, neutral position P → T

8. Function code "R" type, control position A → B

External Dimensions

Cetop 8 / NG25

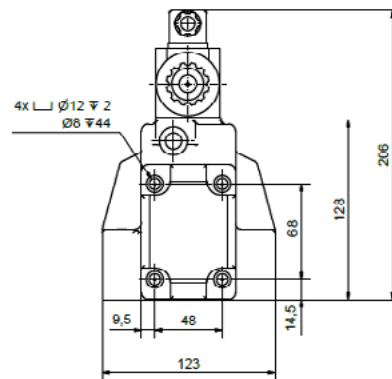
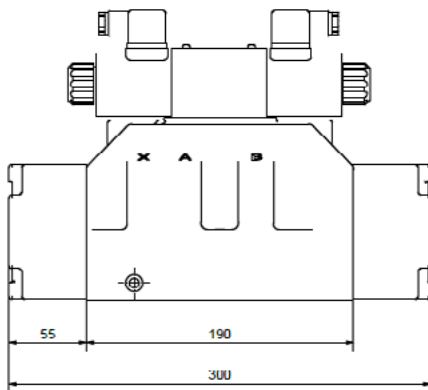
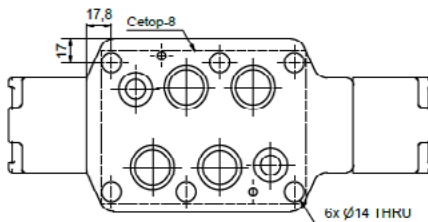

Electro-hydraulic directional control valve

Subplate Size

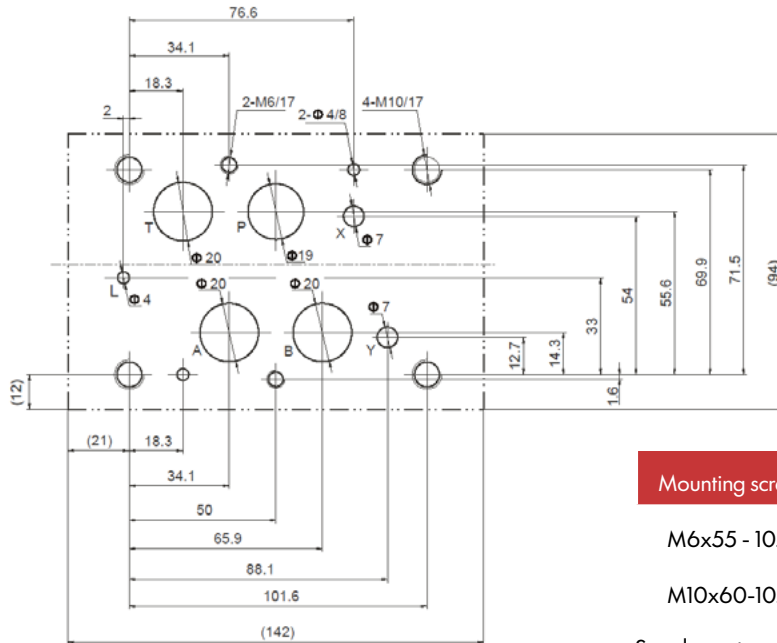

Mounting screw	Amount	Tighten torque
M6x55 - 10.9	2	15Nm
M10x60-10.9	4	75Nm

Supplementary explanation

1. When installing the product, considering horizontal position firstly.
2. The medium used in the hydraulic system must be filtered, its accuracy at least $20 \mu\text{m}$.
3. Screw should be according to the parameters in catalogue.
4. The surface, connecting with the valve, should be Ra0.8 roughness, and 0.01/100mm flatness.

External Dimensions

Electro-hydraulic directional control valve

Subplate Size

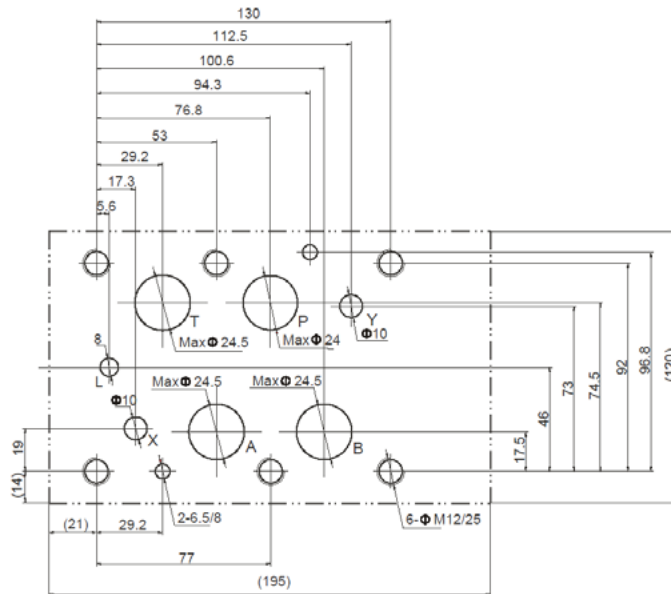

Mounting screw	Amount	Tighten torque
M12x60 - 10.9	6	130Nm

Supplementary explanation

1. When installing the product, considering horizontal position firstly.
2. The medium used in the hydraulic system must be filtered, its accuracy at least 20 μ m.
3. Screw should be according to the parameters in catalogue.
4. The surface, connecting with the valve, should be Ra0.8 roughness, and 0.01/100mm flatness.

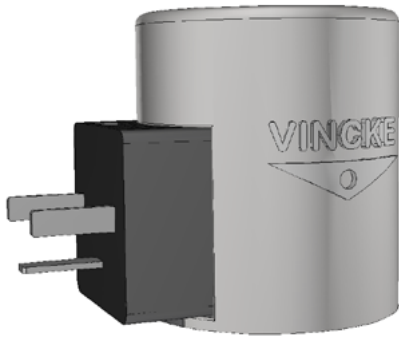

Technical Specification

Specification	Cetop 3 / NG6				Cetop 5 / NG10			
Voltage Type	DC voltage(-DC)	DC voltage(-DC)	Half-wave rectified voltage (B-AC)	Half-wave rectified voltage (B-AC)	DC voltage(-DC)	DC voltage(-DC)	Half-wave rectified voltage (B-AC)	Half-wave rectified voltage (B-AC)
Code	C-6-DC12V	C-6-DC24V	C-6-B-AC110	C-6-B-AC220	C-6-DC12V	C-6-DC24V	C-6-AC110	C-6-AC220
Applicable voltage (V)	DC12V	DC24V	B-AC110	B-AC220	DC12V	DC24V	B-AC110	B-AC220
Allowable voltage fluctuation tolerance (%)	±10	±10	±10	±10	±10	±10	±10	±10
Power consumption (W)	30	30	30	30	36	36	36	36
Power-on duration	ED100%	ED100%	ED100%	ED100%	ED100%	ED100%	ED100%	ED100%
Maximum switching frequency (t/h)	12000	12000	12000	12000	12000	12000	12000	12000
Switching time on (ms)	25~45	25~45	25~45	25~45	25~45	25~45	25~45	25~45
Maximum coil internal temperature rise(°C)	≤150	≤150	≤150	≤150	≤150	≤150	≤150	≤150
Insulation class	F	F	H	H	F	F	H	H
Connector type	DIN43650	DIN43650	DIN43650	DIN43650	DIN43650	DIN43650	DIN43650	DIN43650

External Dimensions

Cetop 3 / NG6

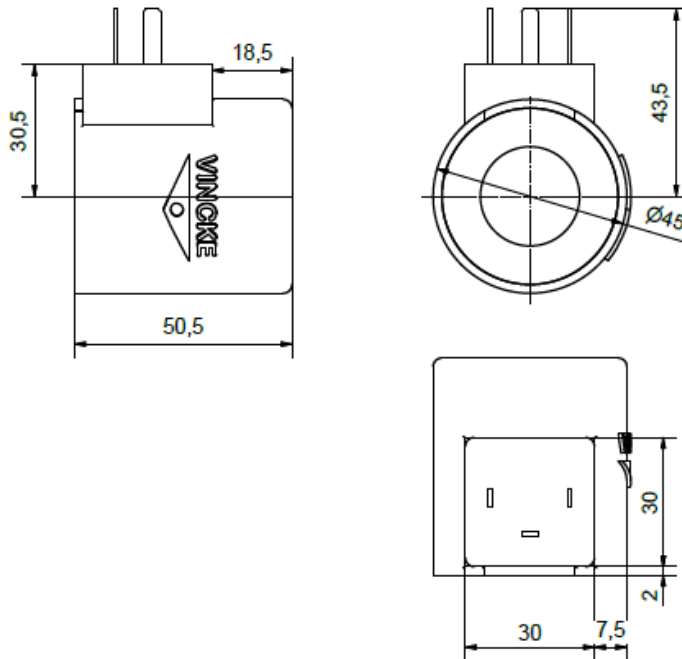

Cetop 5 / NG10

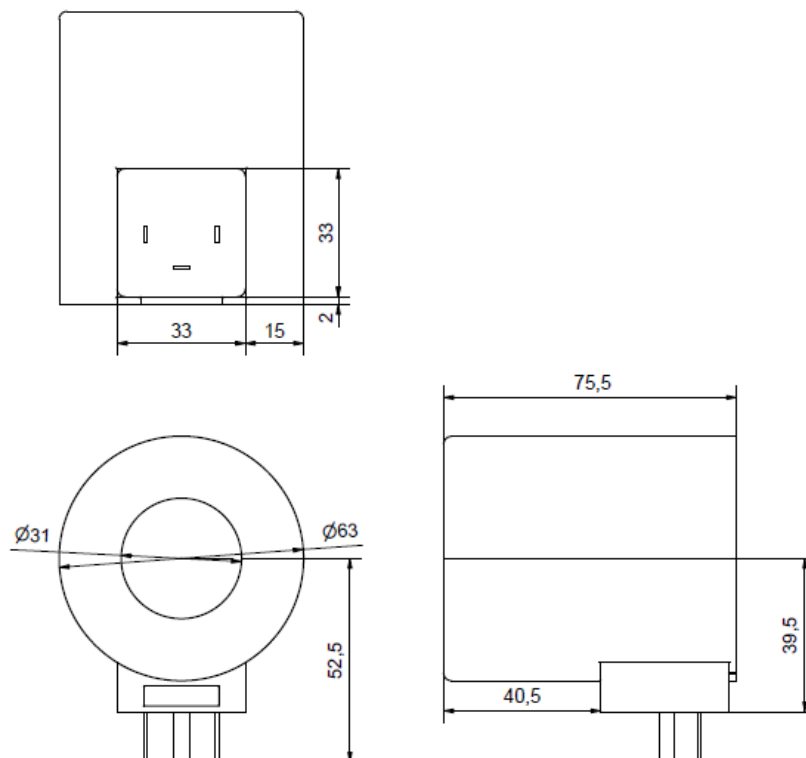

Manual Emergency Positioner



External Dimensions

Cetop 3 / NG6

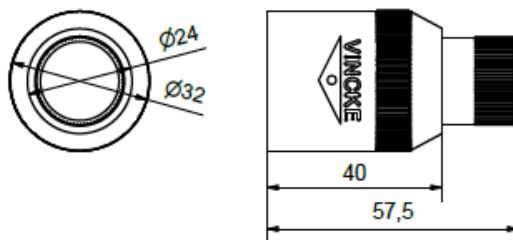

Cetop 5 / NG10

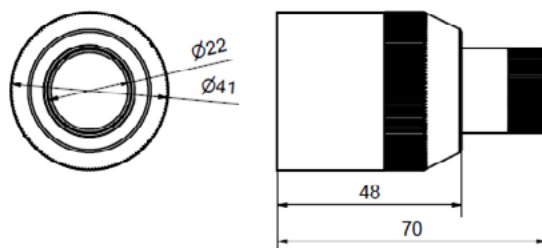

Manual operated directional control valve

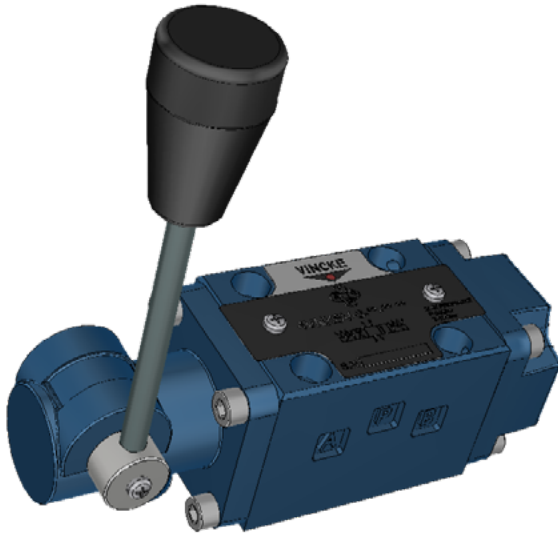

Manual operated directional control valve is a directional control valve, by operating the handle, the spool moves in the axial direction to achieve oil loop switching.

Manual operated directional control valve and electrical operated directional control valve are played the same role in the hydraulic system. Easy operation, reliable work, and without the need for electricity

Technical Specification

Specification	Cetop 3 / NG6	Cetop 5 / NG10
Working pressure (Mpa)	Port P,A,B	31.5
	Port T	16
Max. Flow (L/min)	60	100
Working fluid	Mineral oil: phosphate-ester	
Fluid temp. (°C)	-20~70	
Viscosity (mm ² /s)	2.8~380	
Weight (kg)	About 1.4	About 3.3

Cleanliness

The maximum allowable cleanliness of the oil should be according to 9th degree of Standard NAS1638. It is suggested that the minimum filter rating should be $\beta_{10} \geq 75$.

Manual operated directional control valve

Ordering Code

4VNK-MV-06-*-*-*

Manual operated directional control valve

Nominal size 6 Cetop 3 or 10 Cetop 5

Spool type E, G, J etc.

Omit Spring return
OF With detent

Seal material
Omit NBR Seals
V FPM Seals

Omit without damping
08 ϕ 0.8 Damping
10 ϕ 1.0 Damping
12 ϕ 1.2 Damping

Code Symbol

4VNMV

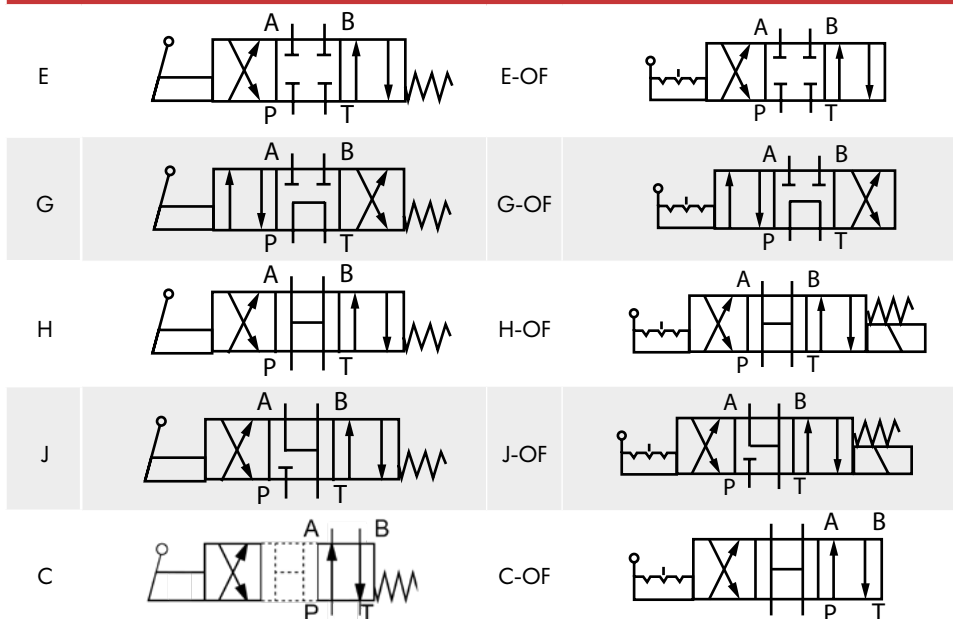

Manual operated directional control valve

Specification Working limits

As the plug, the switch function of the valve is determined by the filter. In order to reach the largest flow as shown, we suggested to use full-flow filter 20 μ m. Every force on the valve can also affect the flow. With regard to the four-way valve, the normal flow data as shown is get from the regular use of two directions of the flow (e.g.P to A, and simultaneous return flow from B to T). See tables. If only one flow direction is needed, for example: When a four port valve which is closed up port A or port B, used as a three-way valve, the Maximum flow may be very small in the serious condition.

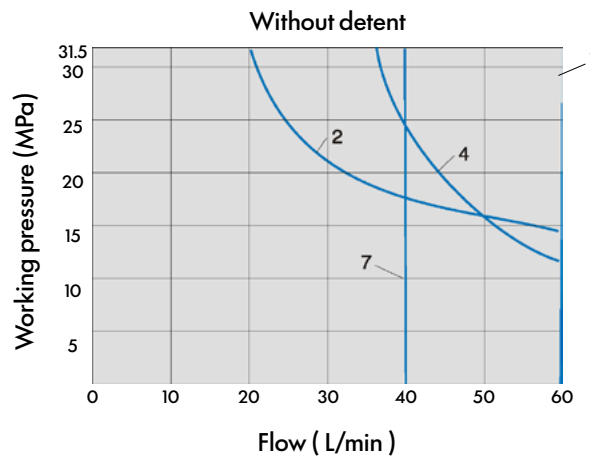
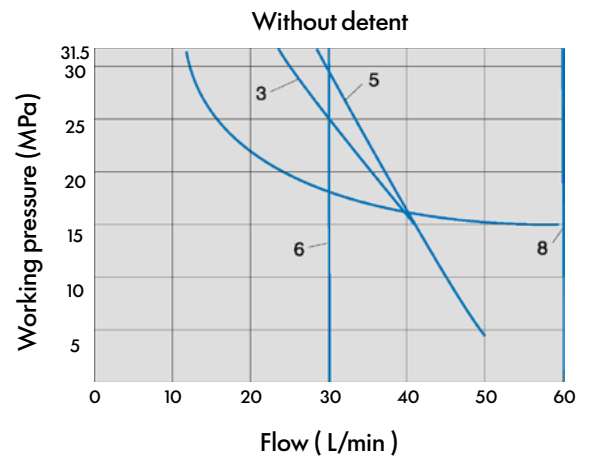
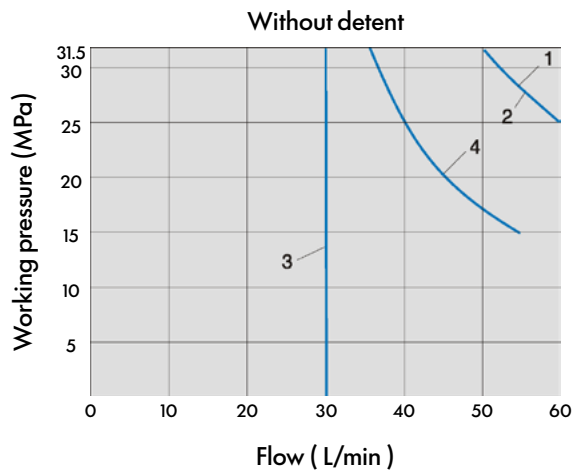

4. Spool symbol "G" in the median position P to T.

Performance curve	Function code
-------------------	---------------

Without detent	1	E, H, C, G, J
----------------	---	---------------

Performance curve	Function code
-------------------	---------------

Without detent	1	H, C
With detent	2	E, J
	3	G

Manual operated directional control valve

The Relationship Between the Location of the Handle and the Directional of the Oil Flow

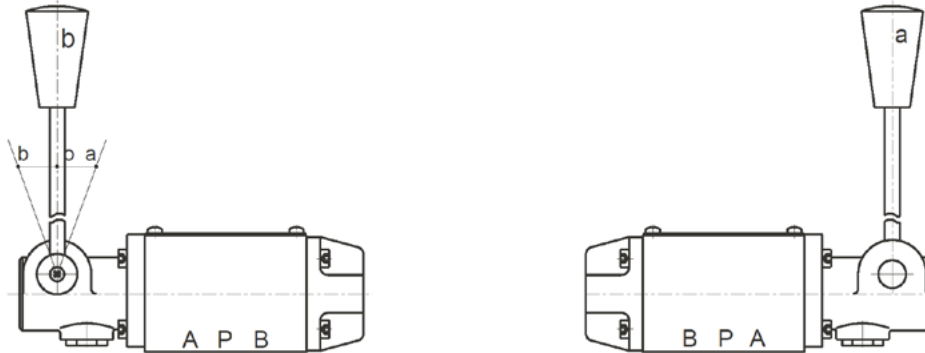

1. The name of the handle as shown in the picture
2. When the handle is on position P→B A→T
3. When the handle is on position P→A B→T
4. Oil flow in the opposite direction with the above-mentioned movement for 02/03: G.
Oil flow in the opposite direction with the above-mentioned movement for 04/06: G.

Specification Performance curve

Pressure loss (MPa)

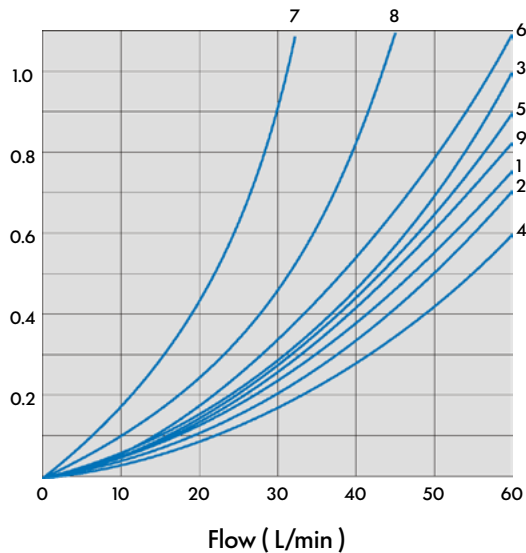

Function Code	Direction			
	P→A	P→B	A→T	B→T
C	1	1	3	1
E	3	3	1	1
G	6	6	9	9
H	2	4	2	2
J	1	1	2	1

Manual operated directional control valve

Pressure loss (MPa)

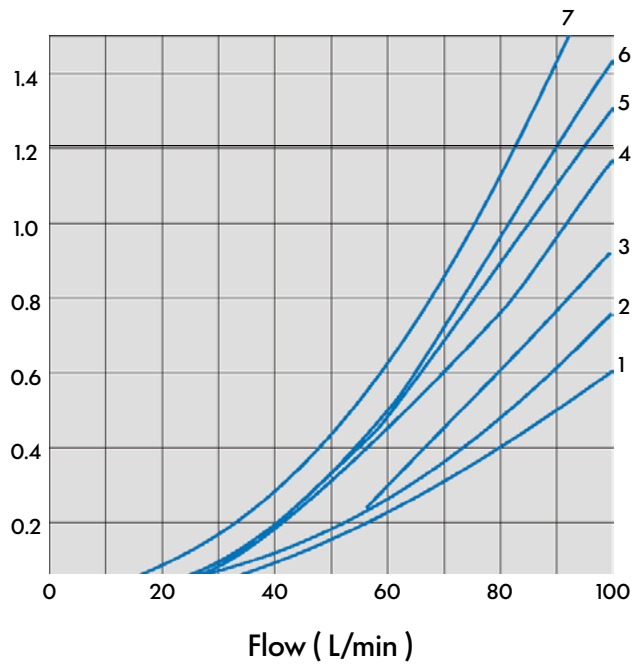

	P → A	P → B	A → T	B → T
C	2	2	3	3
E	2	2	4	4
G	3	3	4	6
H	1	1	4	5
J	2	2	3	3

4. Spool symbol "G" in the median position P → T.

With detent

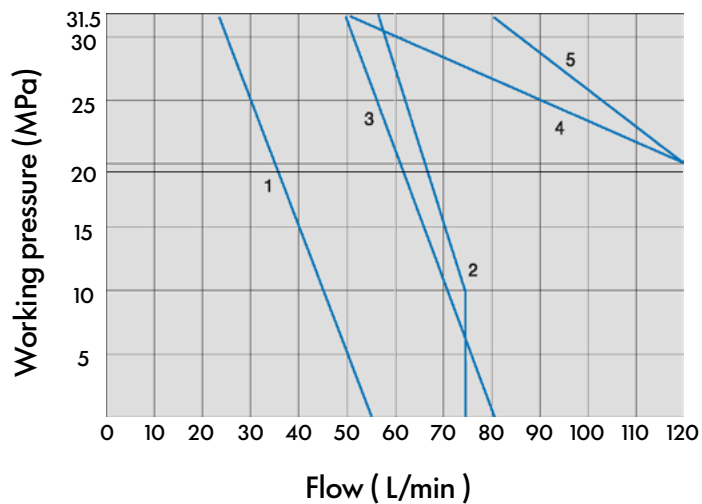

1	H
2	G
3	J
4	C, E

Manual operated directional control valve

External Dimensions

Cetop 3

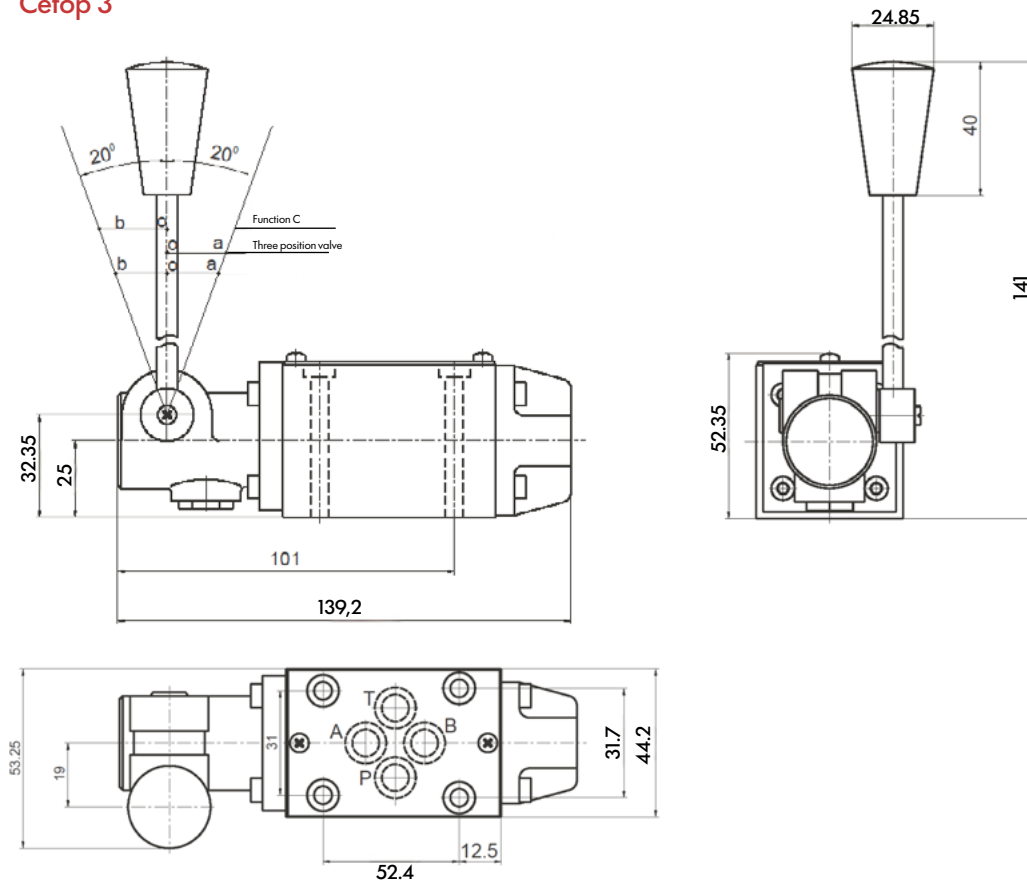

Size of Subplate Oil Port

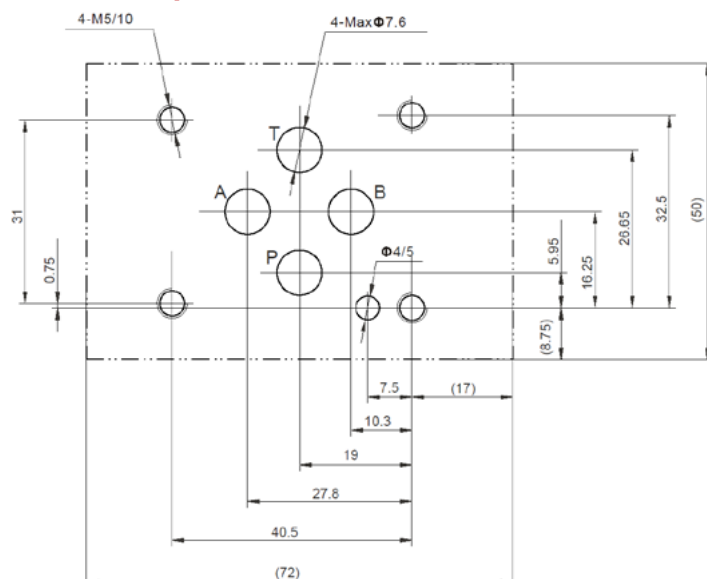

Mounting screw	Amount	Tighten torque
----------------	--------	----------------

M5x50 - 10.9	4	9Nm
--------------	---	-----

Supplementary explanation

1. When installing the product, considering horizontal position firstly.
2. The medium used in the hydraulic system must be filtered, its accuracy is at least 20 μ m.
3. Screw should be according to the parameters in catalogue.
4. The surface, connecting with the valve, should be Ra0.8 roughness, and 0.01/100mm flatness.

Manual operated directional control valve

Size of Subplate Oil Port

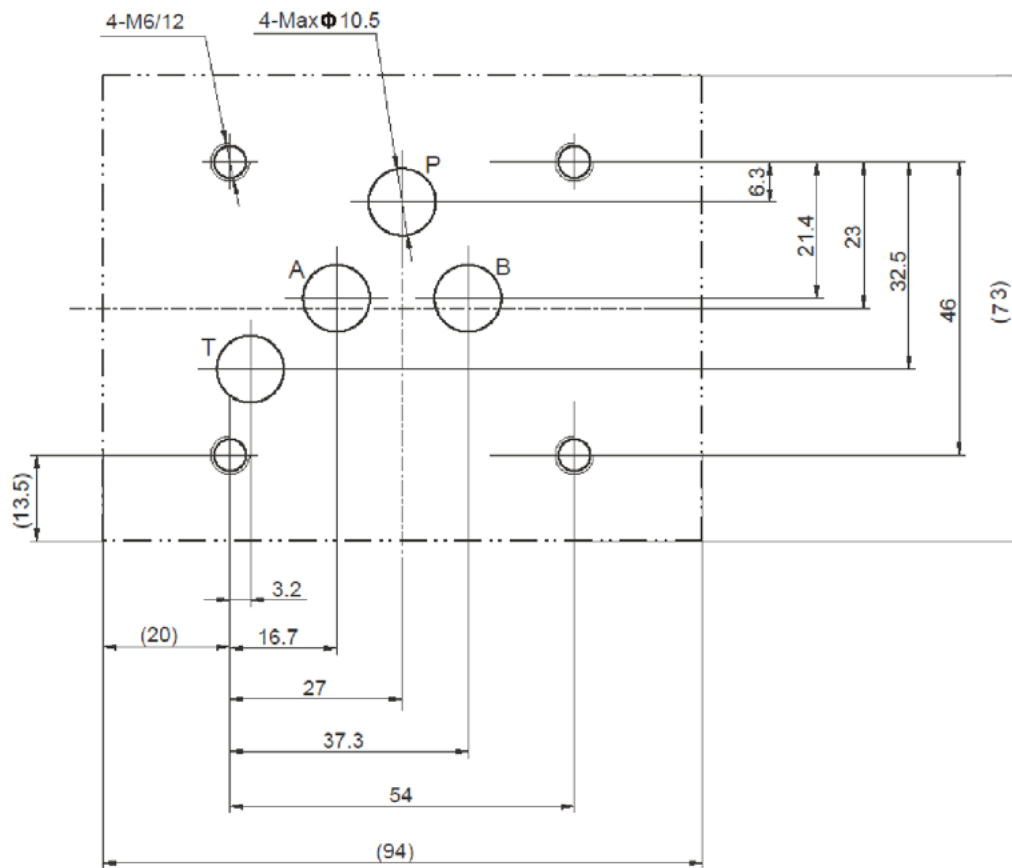

Mounting screw	Amount	Tighten torque
M6x50 - 10.9	4	15Nm

Supplementary explanation

1. When installing the product, considering horizontal position firstly.
2. The medium used in the hydraulic system must be filtered, its accuracy is at least $20 \mu\text{m}$.
3. Screw should be according to the parameters in catalogue.
4. The surface, connecting with the valve, should be Ra0.8 roughness, and 0.01/100mm flatness.

**MODULAR REVERSIBLE FLOW
CONTROL VALVE**

Pág 48

MODULAR FLOW CONTROL VALVE

Pág 50

MODULAR RELIEF VALVE

Pág 54

MODULAR REDUCING VALVE

Pág 59

MODULAR CHECK VALVE

Pág 63

**MODULAR PILOT-OPERATED CHECK
VALVE**

Pág 67

MODULAR OVERCENTER VALVE

Pág 71

ELECTRICAL CHECK VALVE

Pág 75

FAST-SLOW CETOP

Pág 78

FLOW CONTROL VALVE

Pág 81

VINCKE
HYDRAULICS

Modular Reversible flow control valve

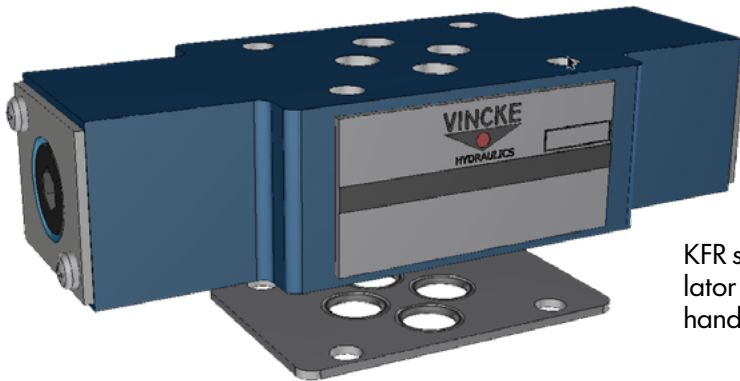

KFR series modular reversible flow regulator valves are used to restrict flow by handle.

Technical Specification

Specification	Cetop 3 / NG6	Cetop 5 / NG10
Max. working pressure (MPa)	31.5	
Max. Flow (L/min)	80	160
Mounting location	Any	
Working fluid	Mineral oil: phosphate-ester hydraulic oil	
Fluid temp. (°C)	-20~70	
Viscosity (mm ² /s)	10~800	

Cleanliness

NAS1638 Class 9, recommended filtration precision Min $\beta_{10} \geq 75$.

Ordering Code

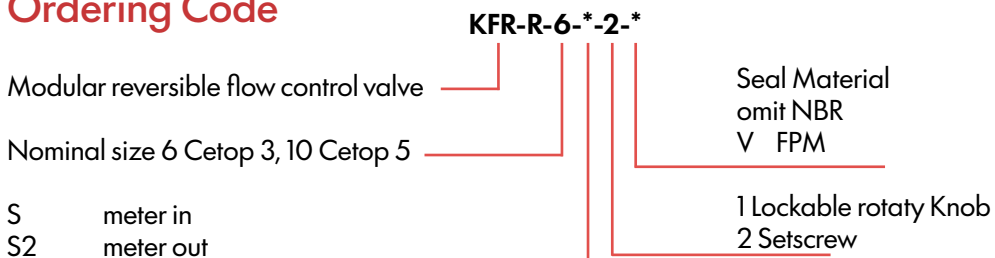

Note: For Dn6 and 10, meter in and meter out can be available by changing the valve body 180° so all these 2 types are marked with "S";
For Dn6, S4 is converted from S3, so these 2 types are marked with S3.

Modular flow control valve

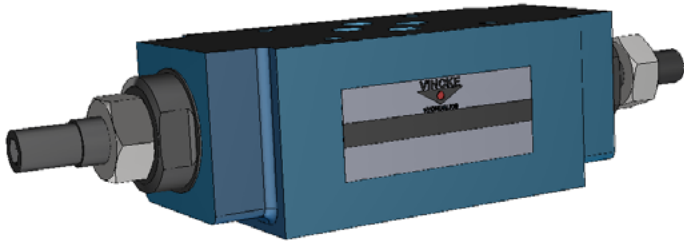

KFR series modular flow regulator valves are used to restrict flow by handle.

Technical Specification

Specification	Cetop 3 / NG6	Cetop 5 / NG10	Cetop 7 / NG16	Cetop 8 / NG25
Max. working pressure (MPa)	35			
Max. Flow (L/min)	30	50	80	360
Hydraulic fluid	Mineral oil: phosphate-ester hydraulic oil			
Fluid temp. (°C)	-20~70			
Viscosity (mm ² /s)	2.8~380			
Opening pressure (MPa)	α: 0.05			

Cleanliness

The maximum allowable cleanliness of the oil should be according to 9th degree of Standard NAS1638. It is suggested that the minimum filter rating should be Min β₁₀ ≥ 75.

Ordering Code

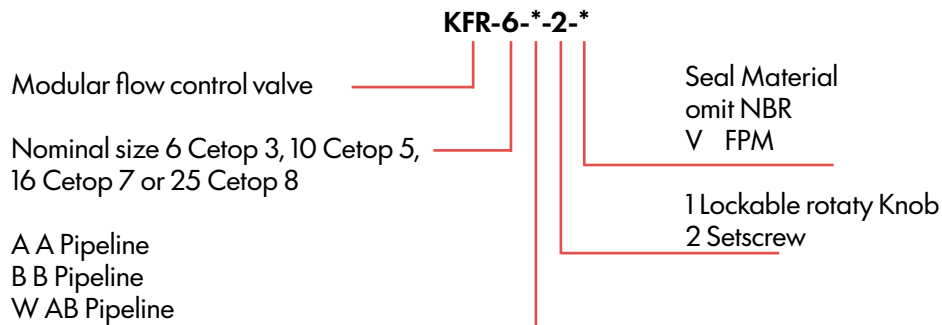

Hydraulic Symbol - Pipeline

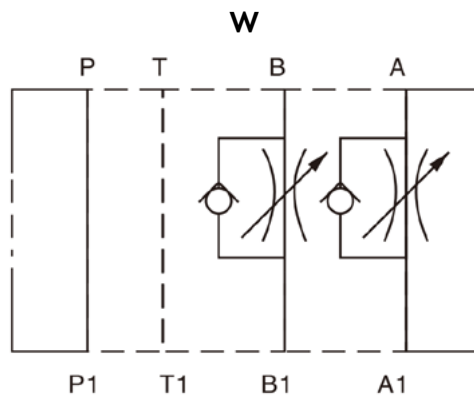
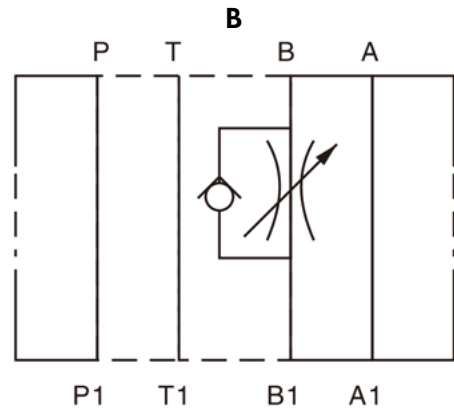
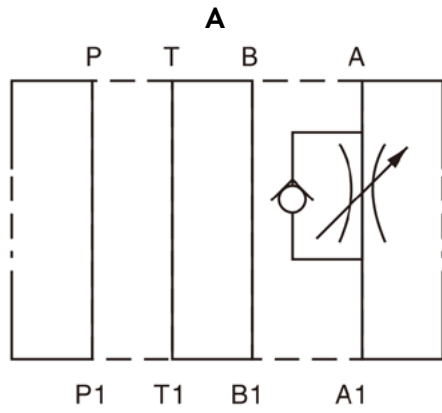

Modular flow control valve

External Dimensions

Cetop 3 / NG6

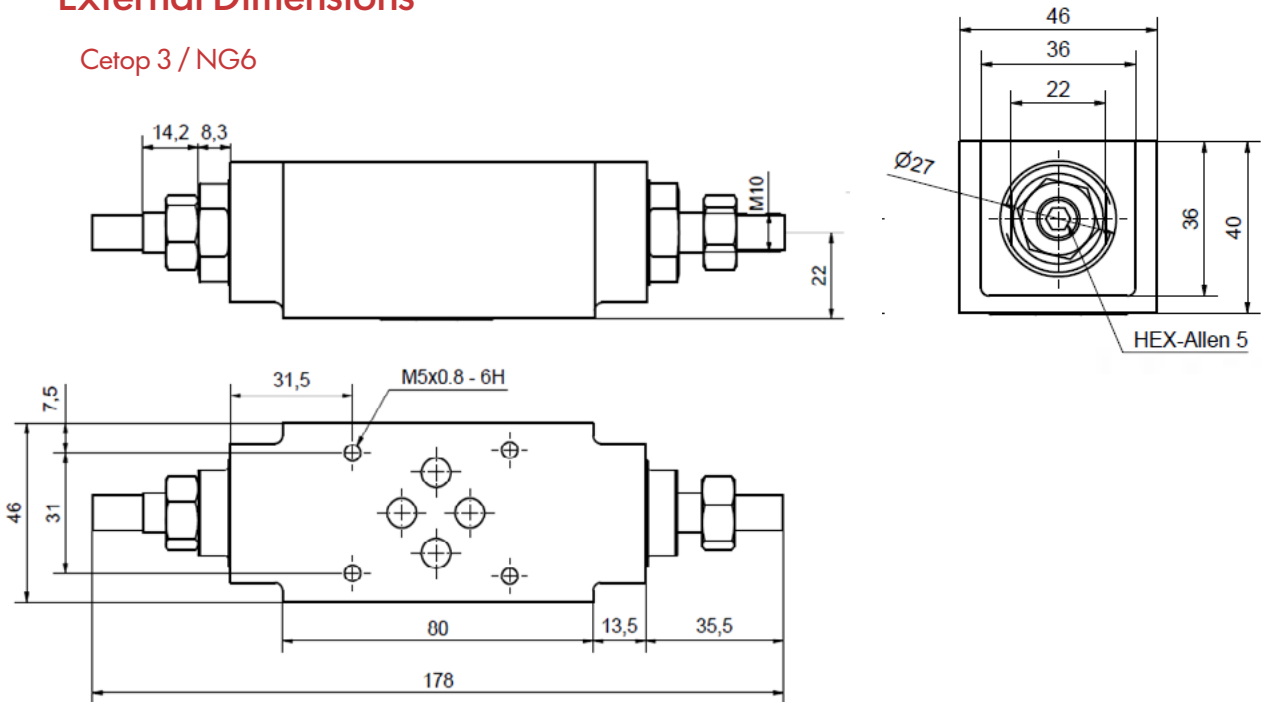

Cetop 5 / NG10

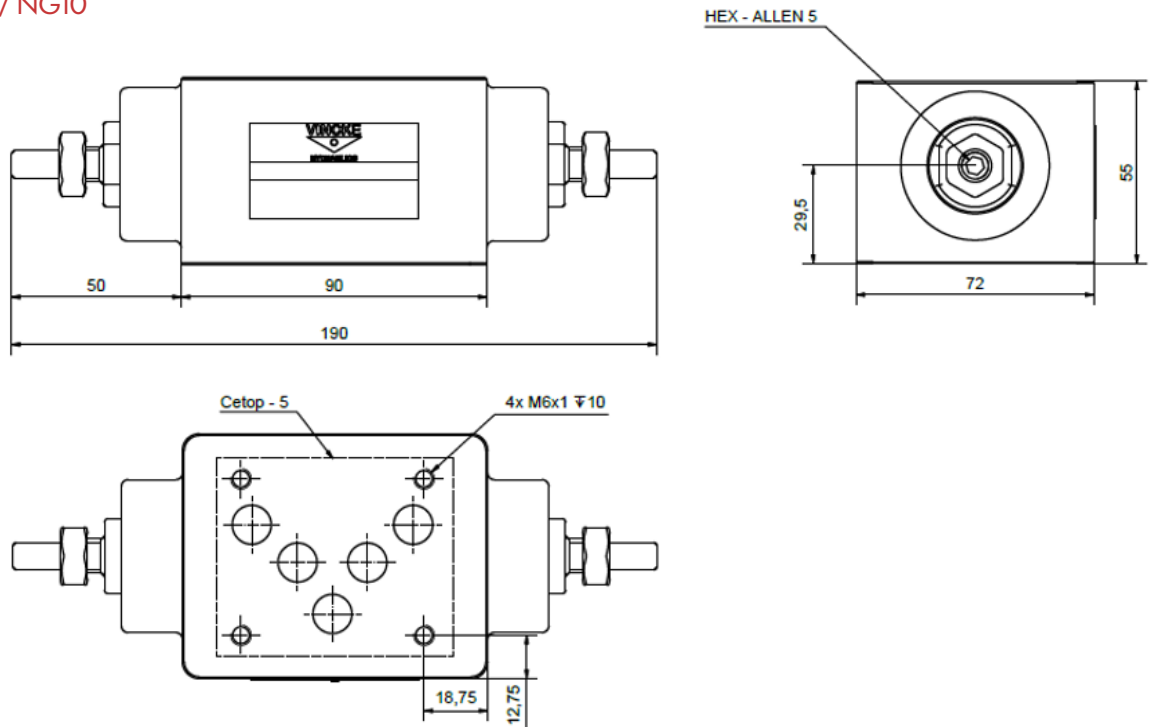

Modular flow control valve

Cetop 7 / NG16

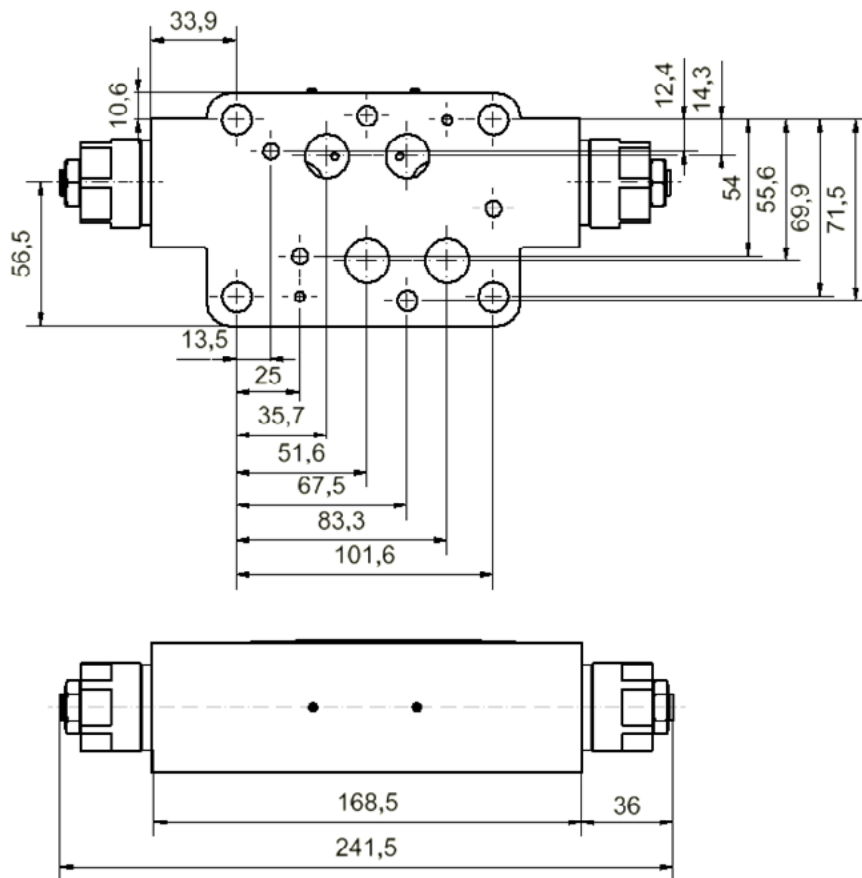

Cetop 8 / NG25

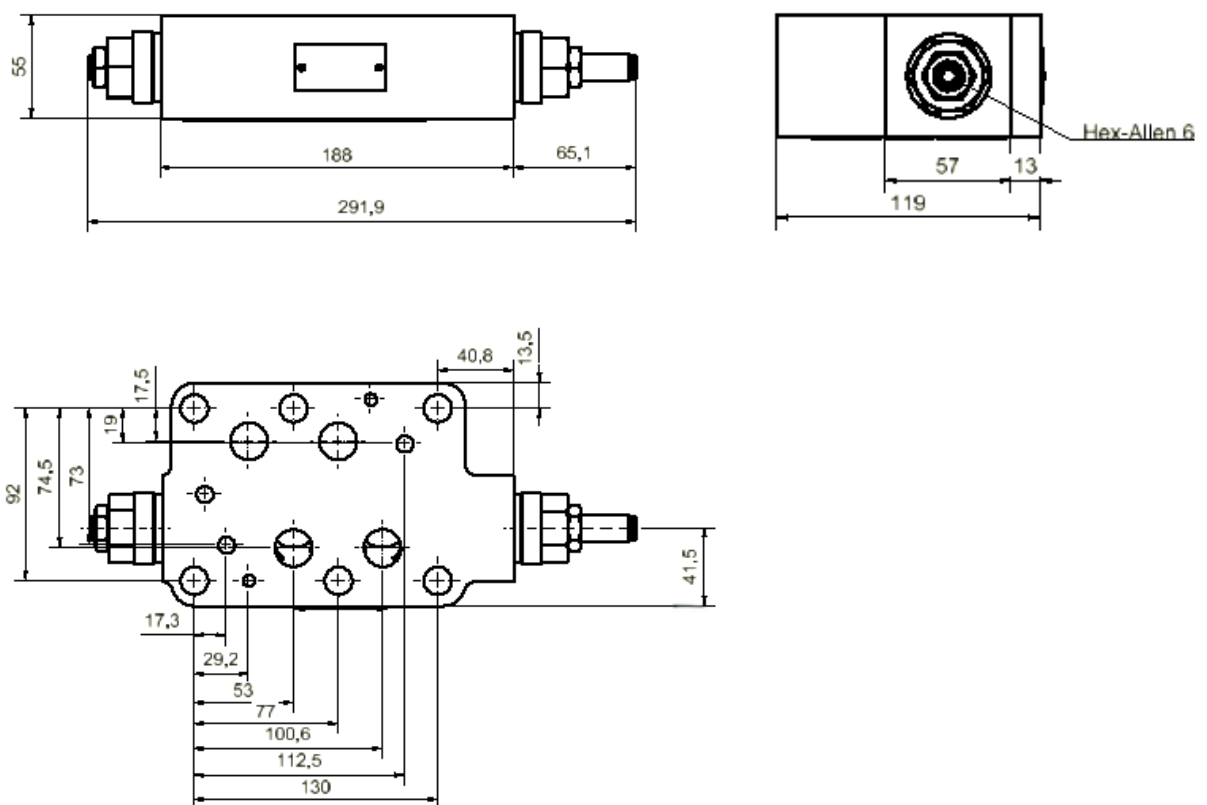

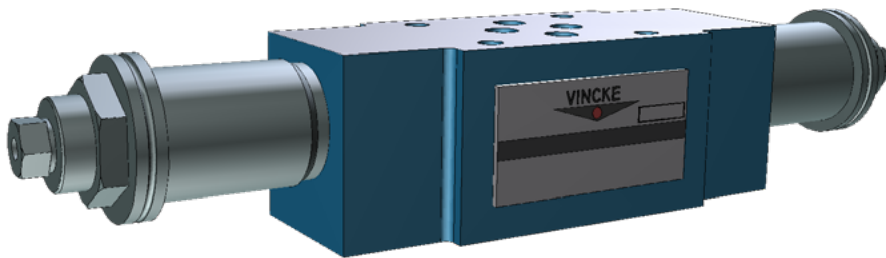

Technical Specification

Specification	Cetop 3 / NG6	Cetop 5 / NG10
Max. working pressure (MPa)	31.5	
Max. Flow (L/min)	60	100
Working fluid	Mineral oil: phosphate-ester hydraulic oil	
Fluid temp. (°C)	-20~70	
Viscosity (mm ² /s)	10~800	
Working voltage (MPa)	5, 10, 20, 31.5	

Cleanliness

NAS1638 Class 9, recommended filtration precision Min $\beta_{10} \geq 75$.

Ordering Code

KRV-6-**-**	
Modular relief valve Nominal size 6 Cetop 3, 10 Cetop 5, Relief method PP → T A A → T B B → T C A → T, B → T D A → B, B → A	Seal Material omit NBR V FPM 1 handle 2 with hexagon and protective cap Pressure range 5 upto 5MPa 10 upto 10MPa 20 upto 20MPa 31.5 upto 31.5MPa

Hydraulic Symbol

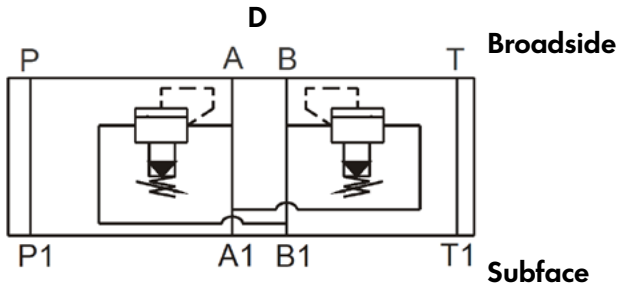
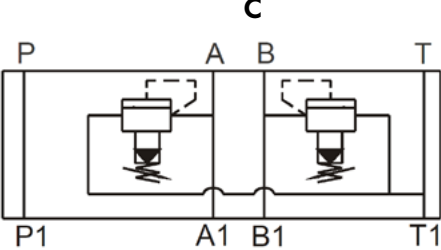
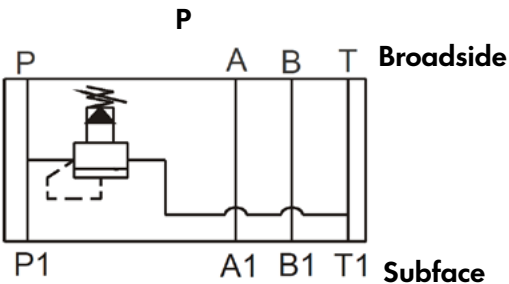
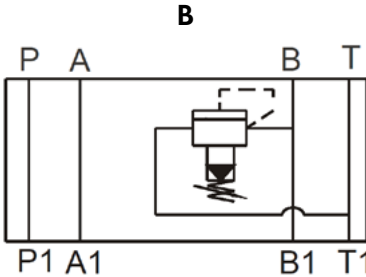
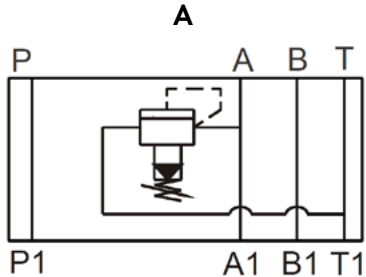

External Dimensions

Cetop 3 / NG6

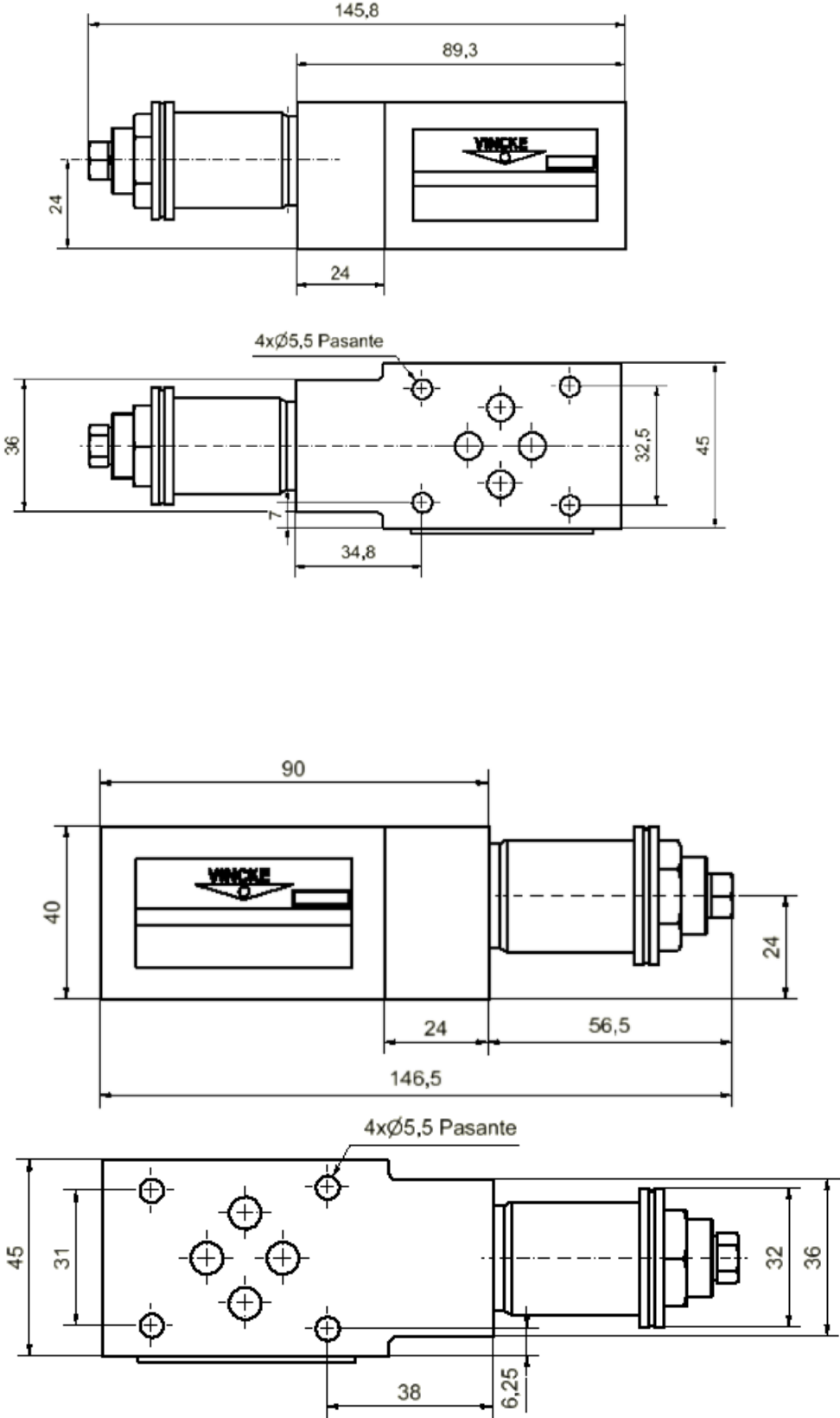

Modular relief valve

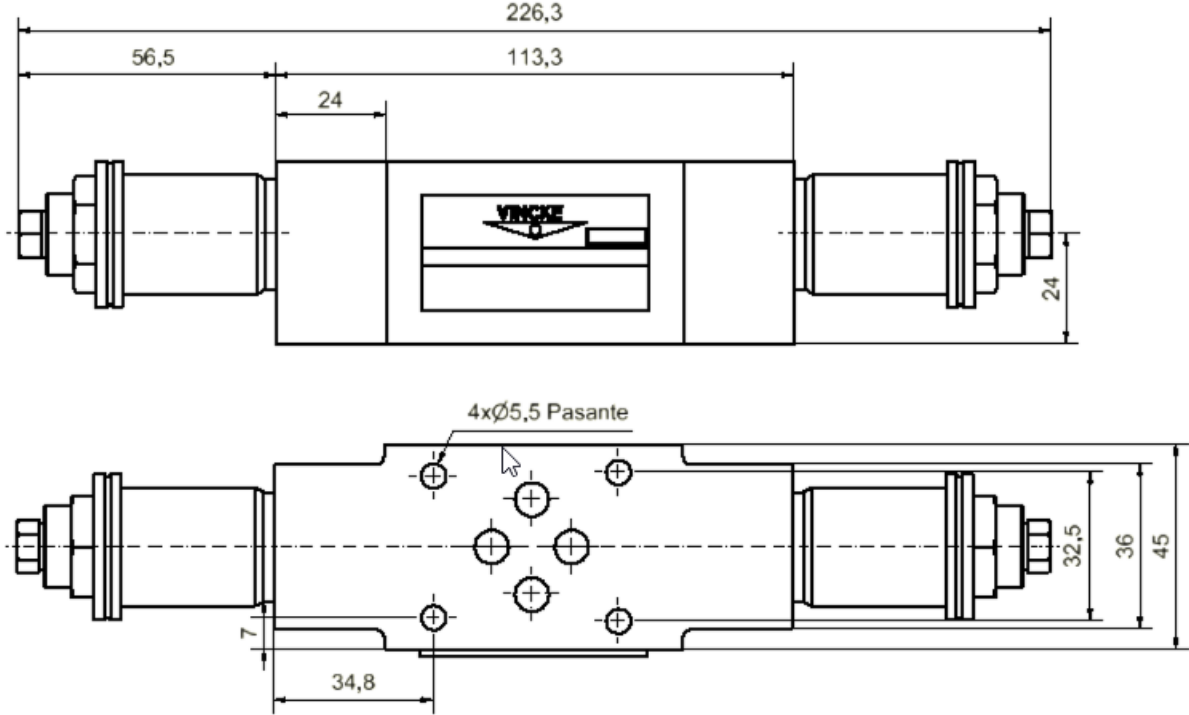

Cetop 5 / NG10

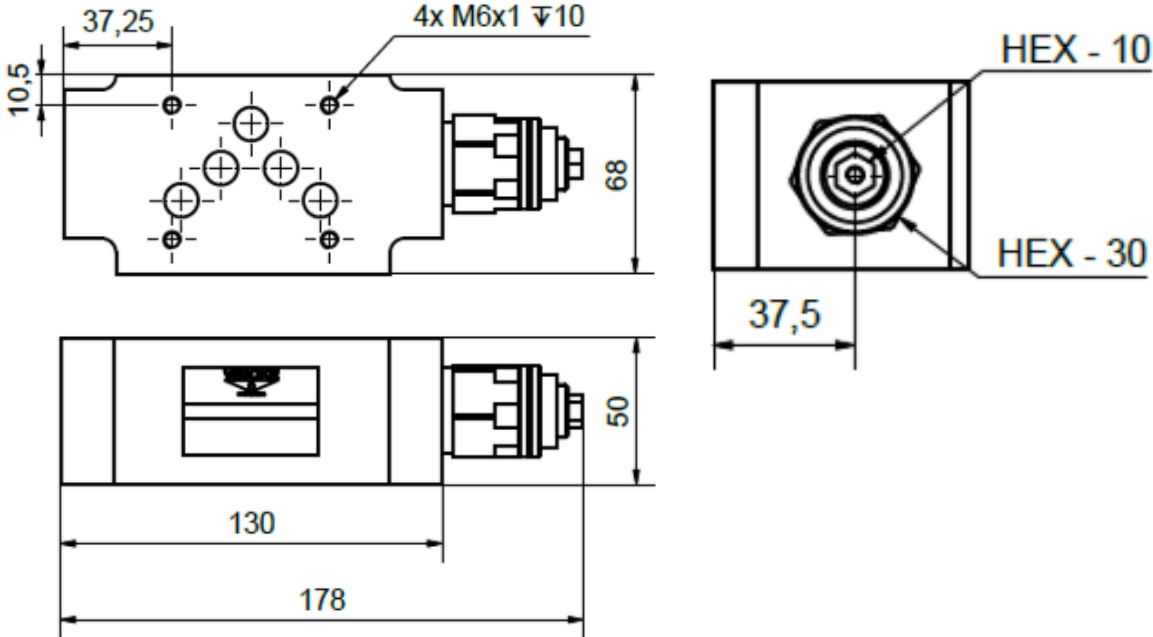

Modular relief valve

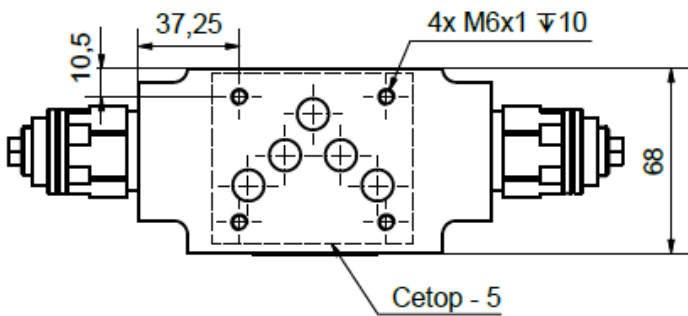
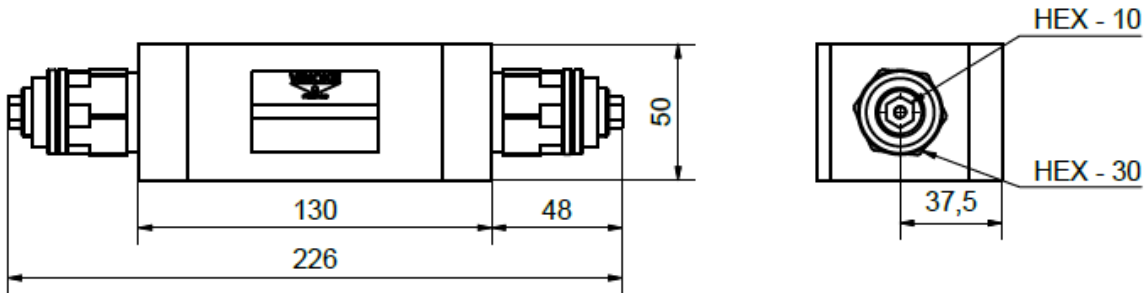
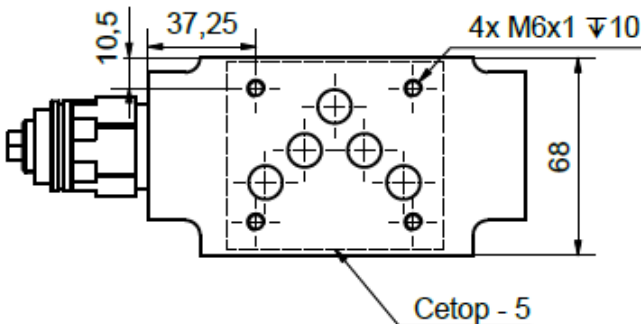
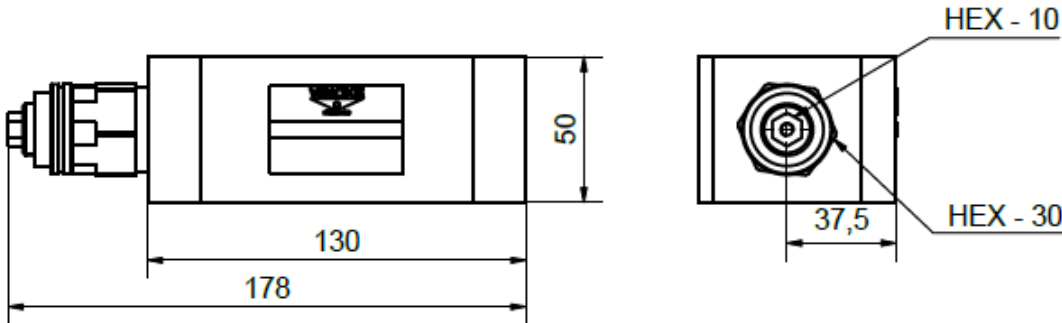

Modular reducing valve

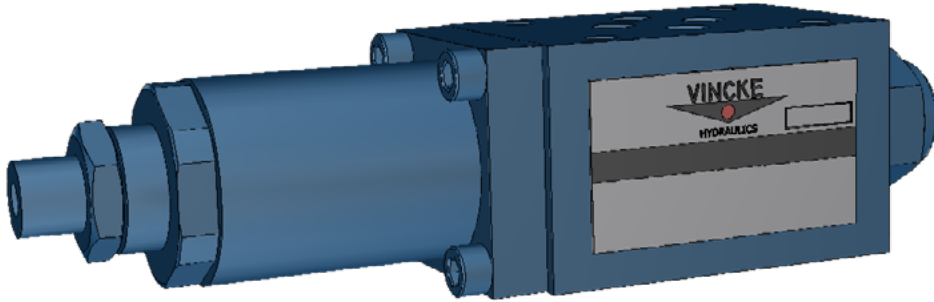

Technical Specification

Specification	Cetop 3 / NG6	Cetop 5 / NG10
Max. working pressure (MPa)	Working pressure	31.5
	Secondary pressure	To21
	Port T	To15
Max Flow (L/min)		50
Mounting location		Any
Working fluid	Mineral oil: phosphate-ester hydraulic oil	
Fluid Temp (C°)		-20~70
Viscosity (Mm ² /s)		10~800

Cleanliness

NAS1638 Class 9, recommended filtration precision Min $\beta_{10} \geq 75$.

Ordering Code

KRDV-6--**-****

Modular reducing valve

Nominal size 6 Cetop 3, 10 Cetop 5,

P P pipeline reducing
A A pipeline reducing
B B pipeline reducing (only for DN10)

2.5 upto 2.5MPa
7.5 upto 7.5MPa
15 upto 15MPa
21 upto 21MPa

Seal Material
omit NBR
V FPM

1 plastic handle
2 steel handle

Omit none
D check valve

Modular reducing valve

Hydraulic Symbol

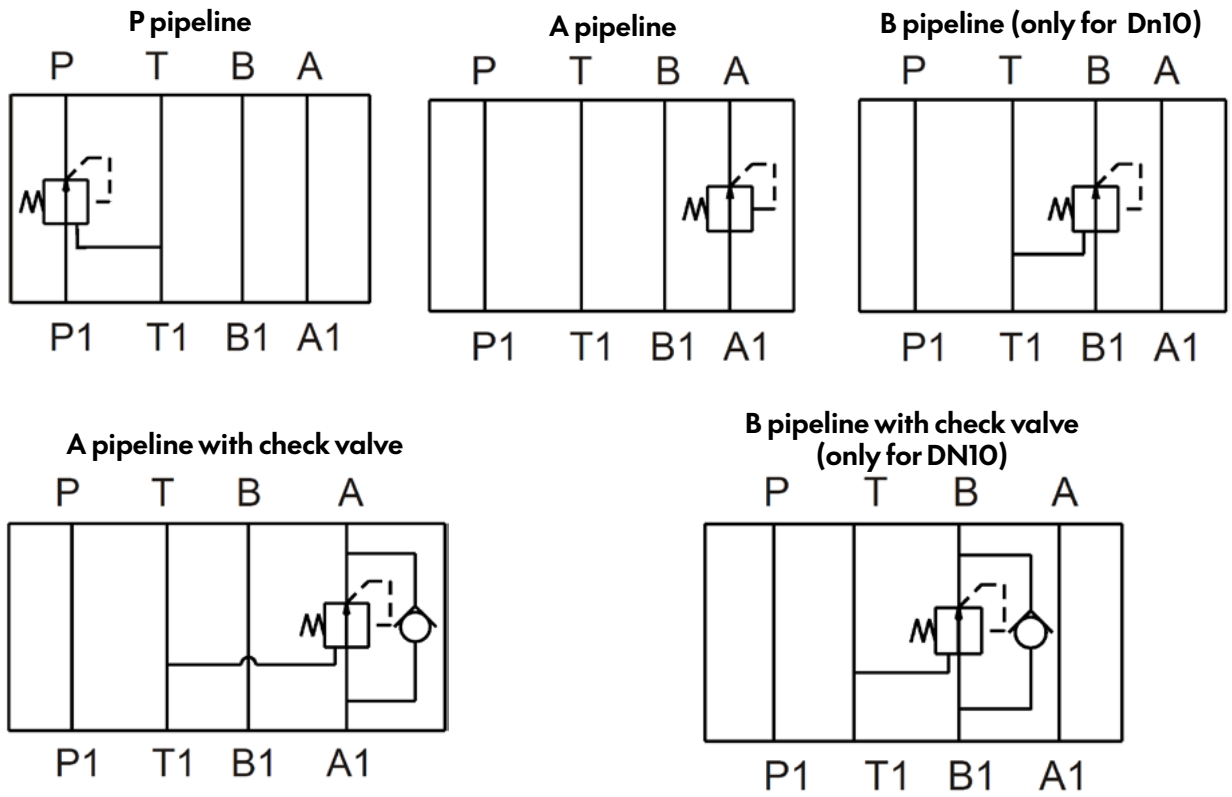

Modular reducing valve

Cetop 3 / NG6

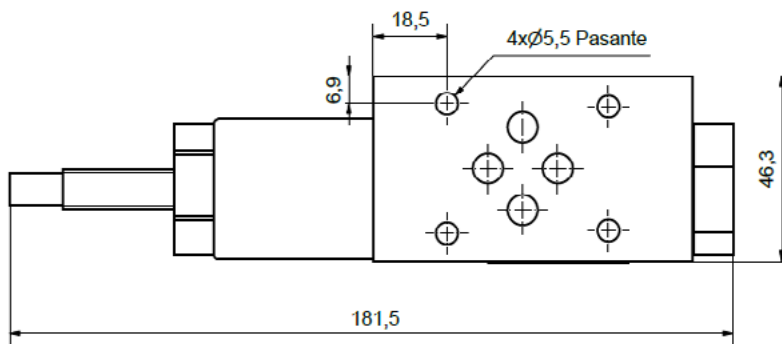
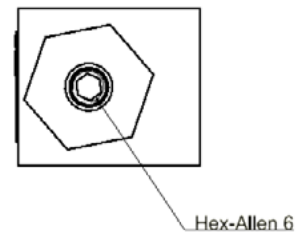
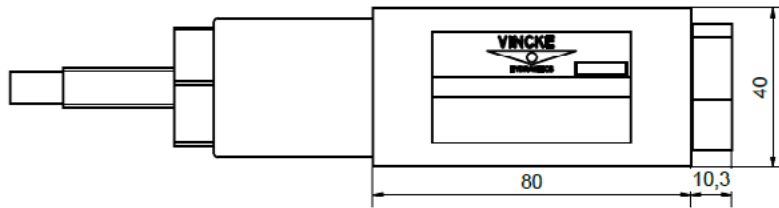
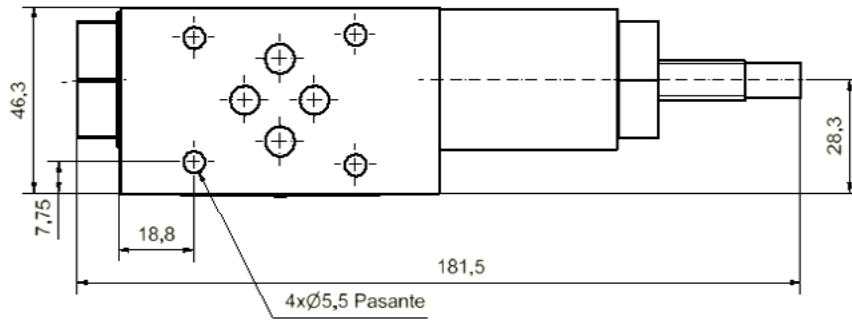
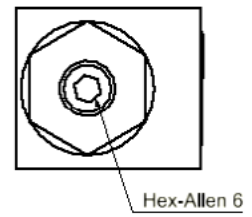
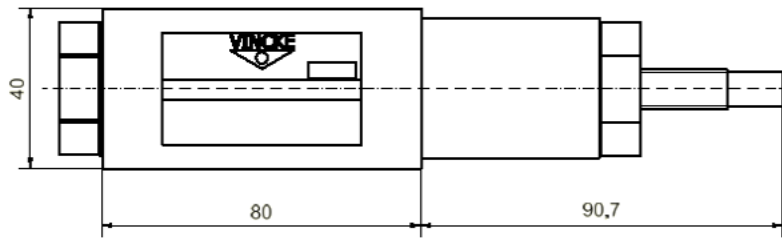

Modular reducing valve

Cetop 5 / NG10

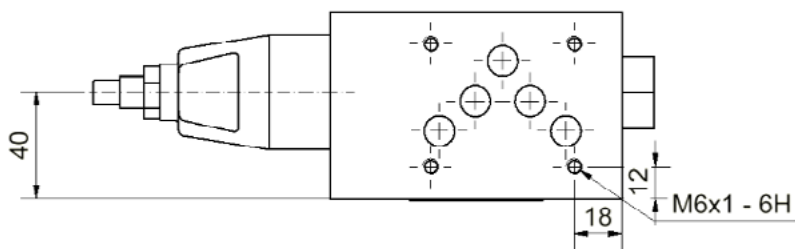
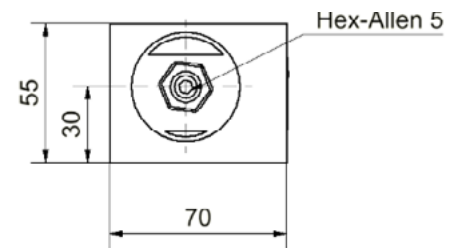
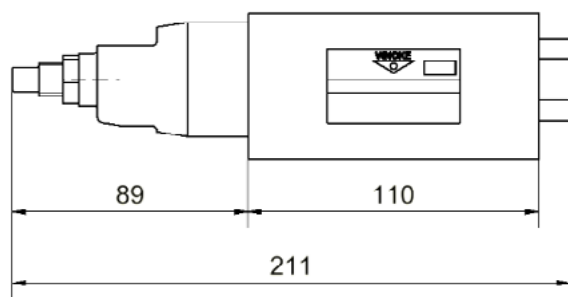
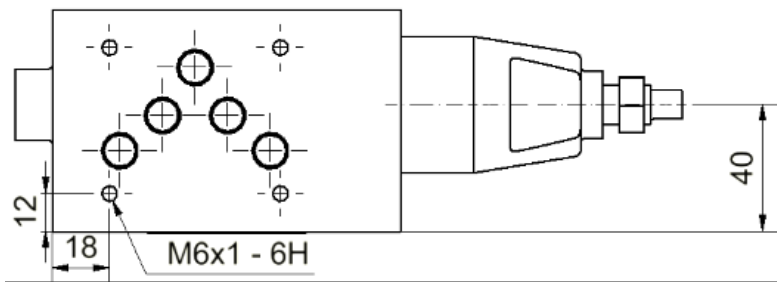
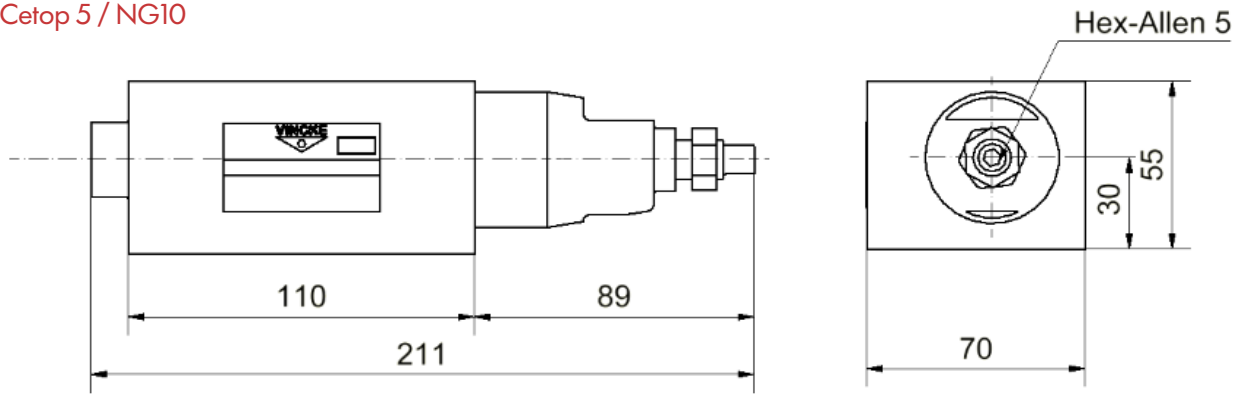

Modular check valve

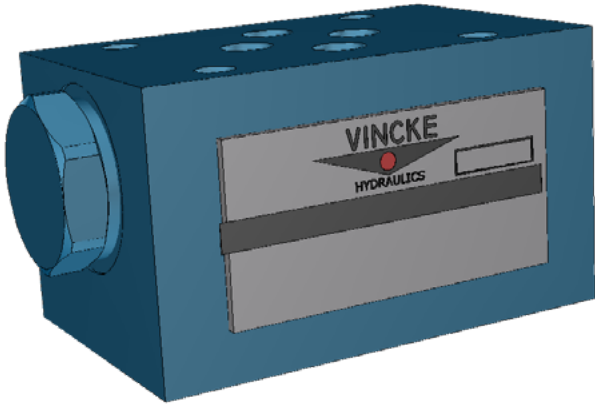

KCV series modular check valves allow free flow in one direction and block flow in the counter direction.

Technical Specification

Specification	Cetop 3 / NG6	Cetop 5 / NG10
Max. working pressure (MPa)	31.5	
Max. Flow (L/min)	40	100
Working fluid	Mineral oil: phosphate-ester	
Fluid temp. (°C)	-20~70	
Viscosity (mm ² /s)	2.8~380	
O penning pressure	a: 0.05 b: 0.25 c: 0.4	

Cleanliness

The maximum allowable cleanliness of the oil should be according to 9th degree of Standard NAS1638. It is suggested that the minimum filter rating should be $\beta_{10} \geq 75$.

Ordering Code

KCV-6-*-**

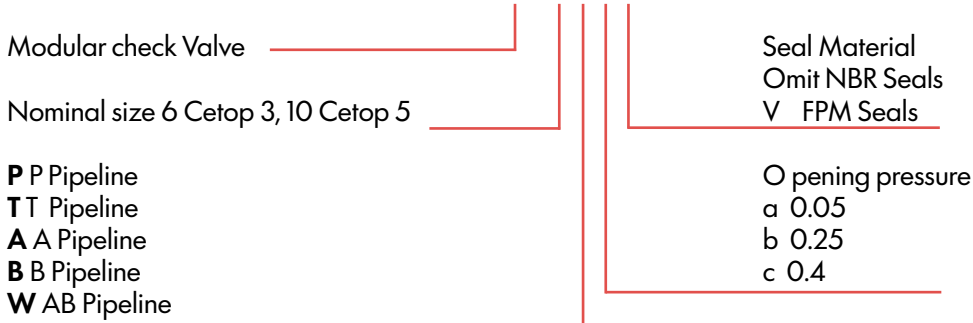

Code Symbol

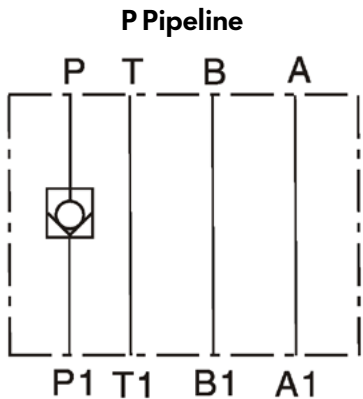

KCV-06-P

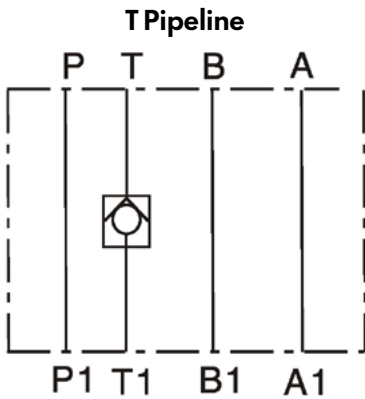

KCV-06-T

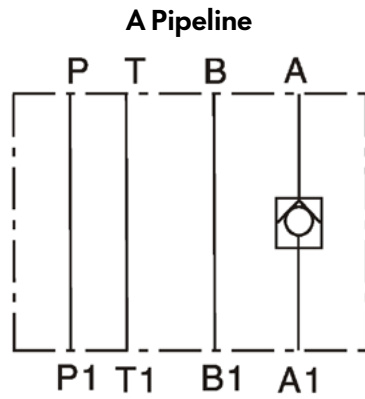

KCV-06-A

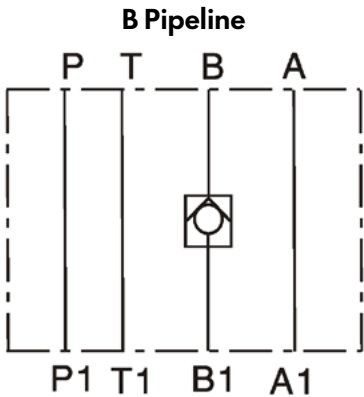

KCV-06-B

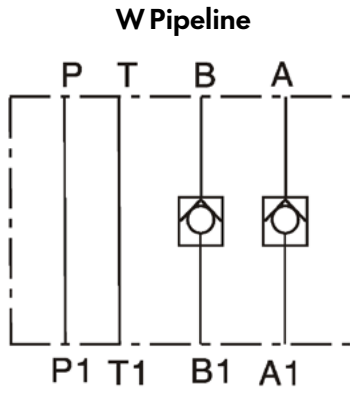

KCV-06-W

External Dimensions

Cetop 3 / NG6

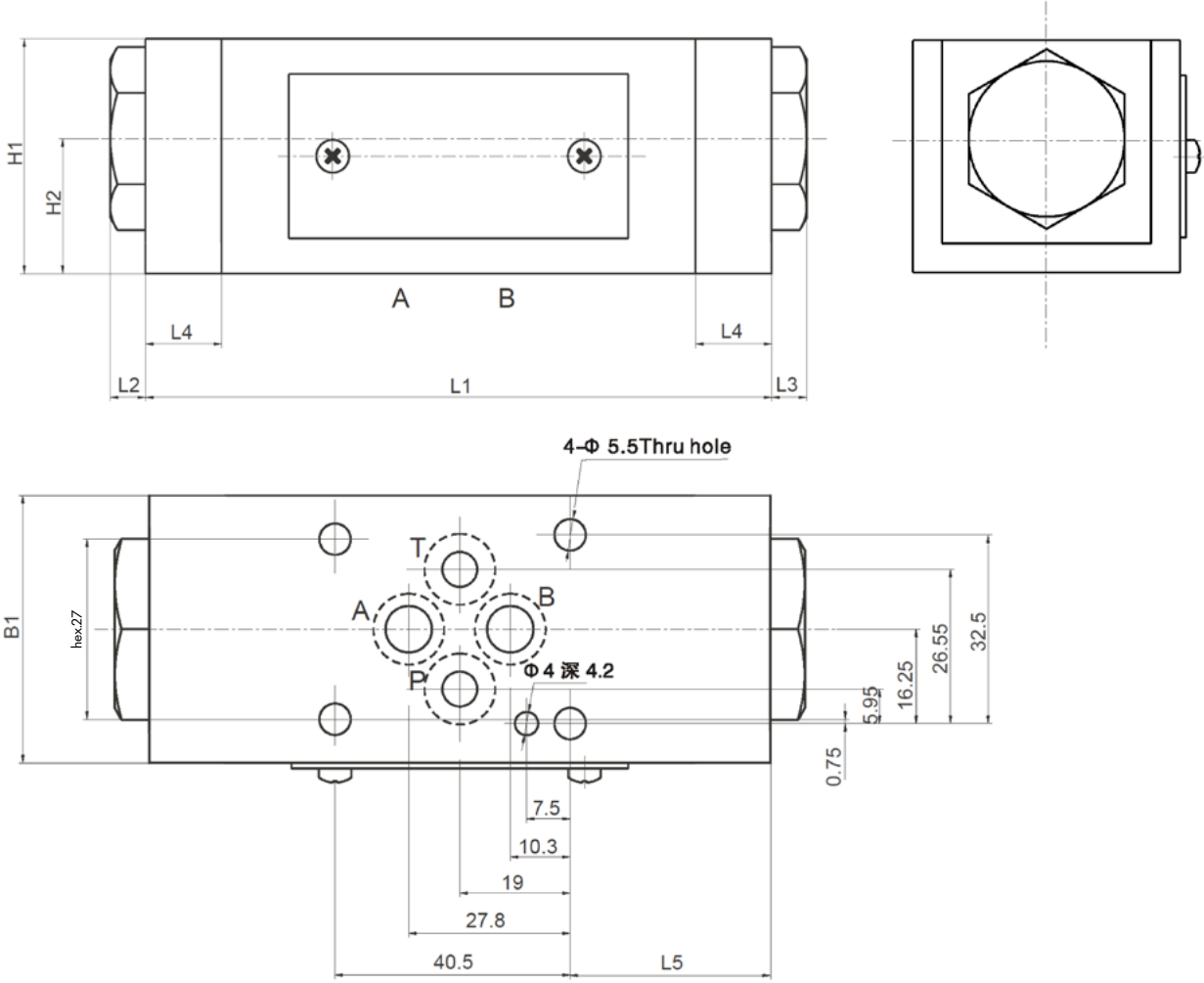

Specification	B1	H1	H2	L1	L2	L3	L4	L5
DA-02-A	46	40	20	80	6	-	-	20
DA-02-B	46	40	20	80	-	6	-	20
DA-02-P	46	40	20	80	-	6	-	20
DA-02-T	46	40	20	80	-	6	-	20
DA-02-W	46	40	23	107	6	6	13	34.5

External Dimensions

Cetop 5 / NG10

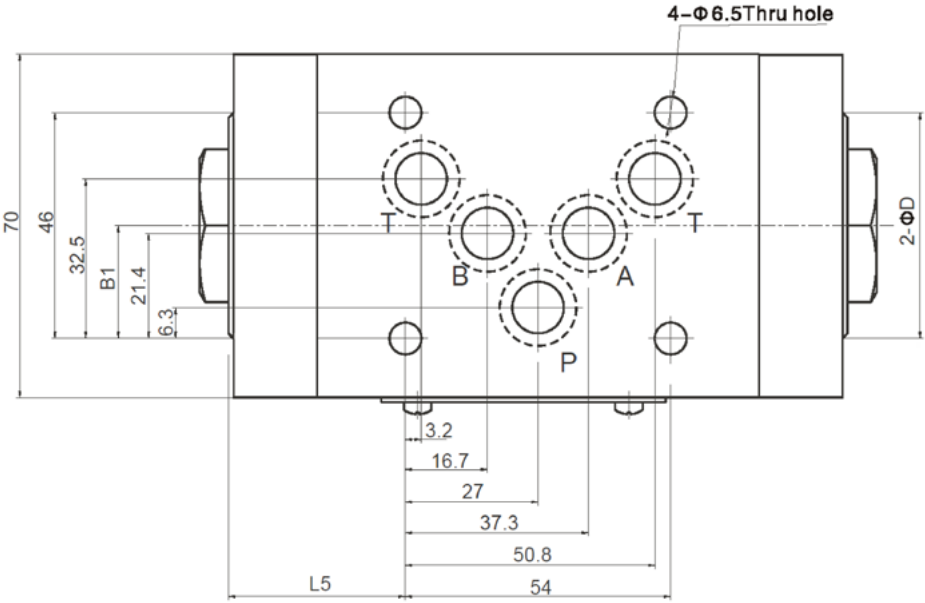
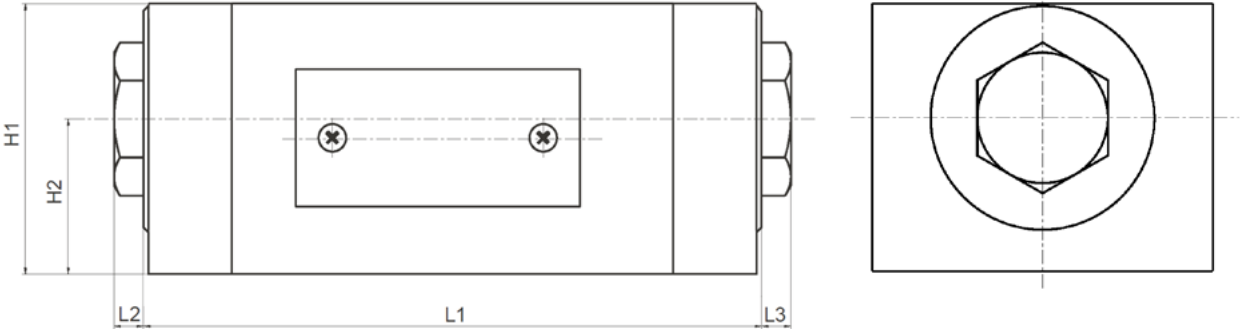

Specification	D	B1	H1	H2	L1	L2	L3	L5
DA-03-A	-	18.5	55	27.5	80	-	6	10
DA-03-B	-	18.5	55	27.5	80	6	-	16
DA-03-P	-	15.8	55	27.5	80	-	6	16
DA-03-T	-	23	55	27.5	100	-	6	19.5
DA-03-W	46	23	55	31.5	126	6	6	36
DA-03-WT	-	32.5	55	27.5	150	6	6	48

Modular pilot-operated check valve

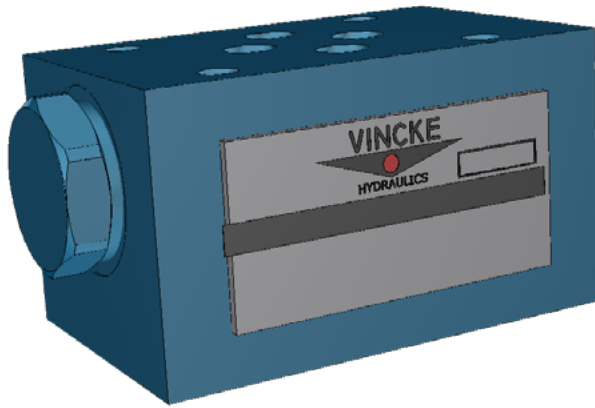

KPCV series modular check valves allow free flow in one direction and block flow in the counter direction.

Technical Specification

Specification	Cetop 3 / NG6	Cetop 5 / NG10	Cetop 7 / NG16	Cetop 8 / NG25
Max. working pressure (MPa)	31.5			
Max. Flow (L/min)	60	100	200	360
Working fluid	Mineral oil: phosphate-ester			
Fluid temp. (°C)	-20~70			
Viscosity (mm ² /s)	2.8~500			
O penning pressure	a: 0.05 b: 0.25 c: 0.4			

Cleanliness

The maximum allowable cleanliness of the oil should be according to 9th degree of Standard NAS1638. It is suggested that the minimum filter rating should be $\beta_{10} \geq 75$.

Ordering Code

KPCV-6--***

Modular Pilot-Operated Check Valve	Seal Material
Nominal size 6 Cetop 3, 10 Cetop 5, 16 Cetop 7 or 25 Cetop 8	Omit NBR Seals V FPM Seals
A A Pipeline	O penning pressure
B B Pipeline	a 0.05
W AB Pipeline	b 0.25
	c 0.4

Modular pilot-operated check valve

Code Symbol

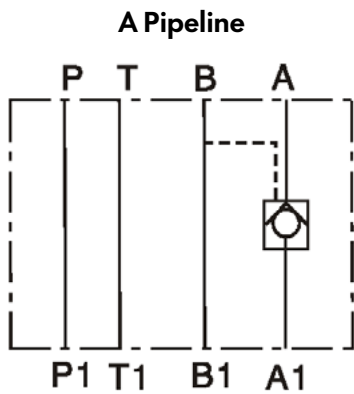

KPCV-06-A

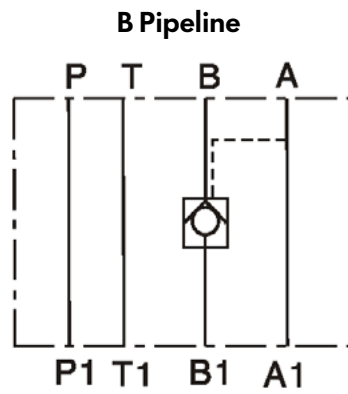

KPCV-06-B

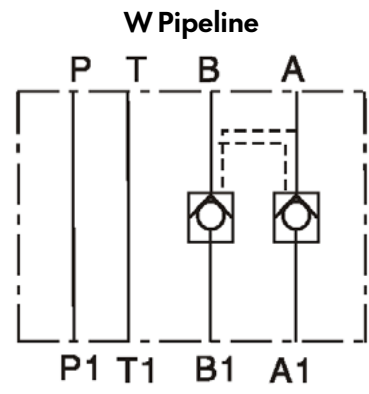

KPCV-06-W

External Dimensions

Cetop 3 / NG6

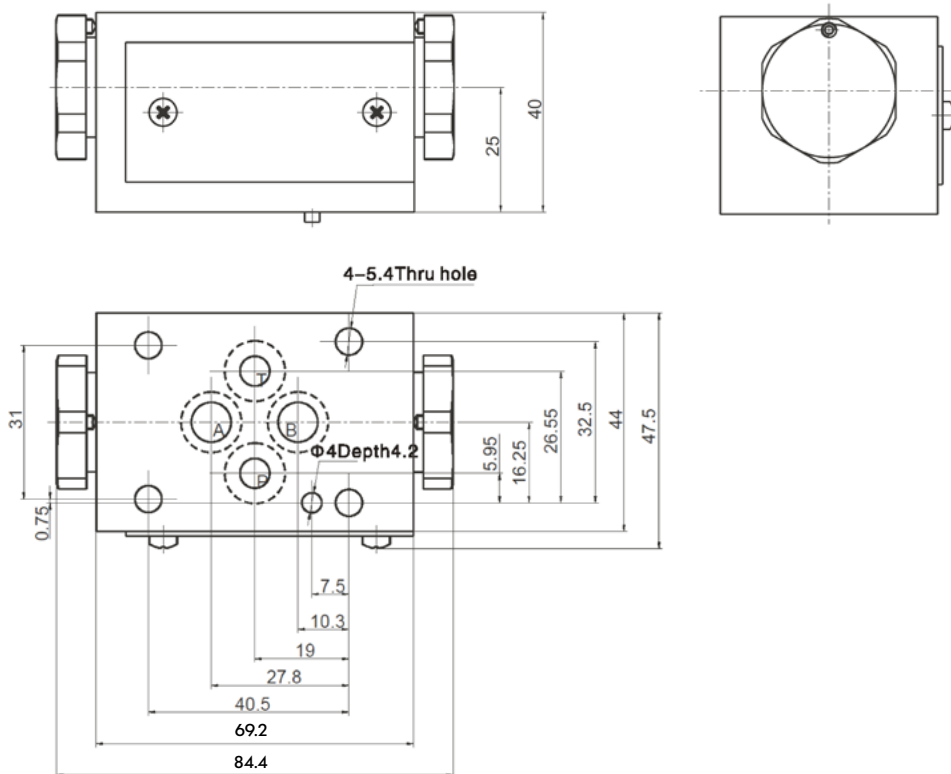

Modular pilot-operated check valve

Cetop 5 / NG10

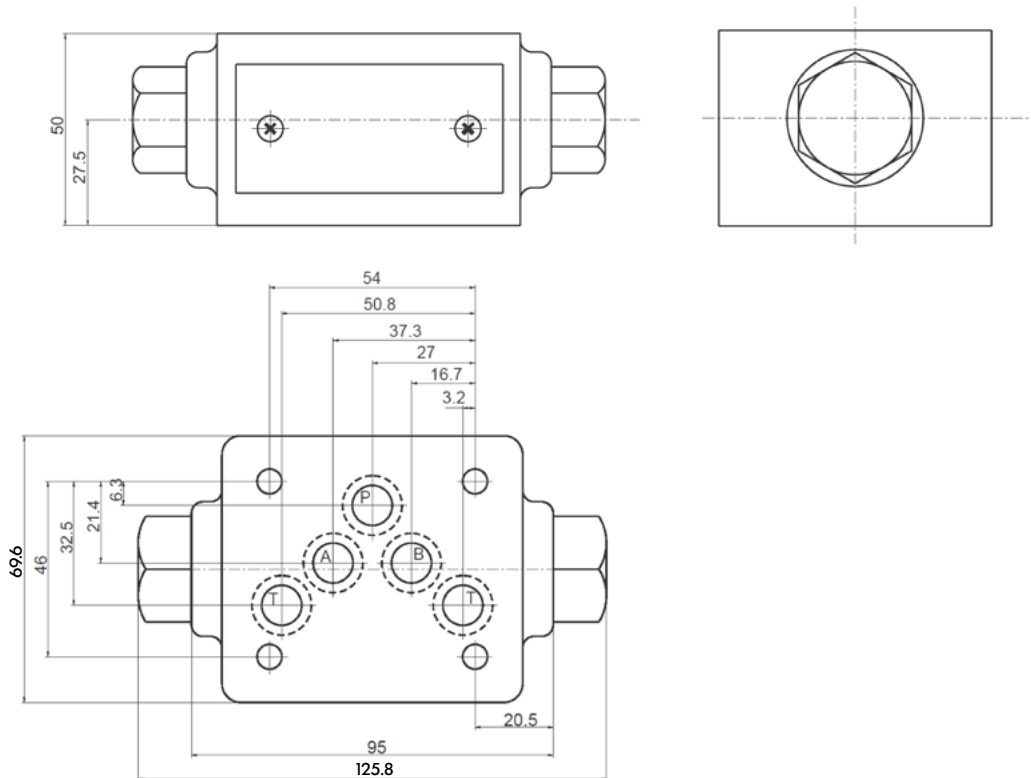

Cetop 7 / NG16

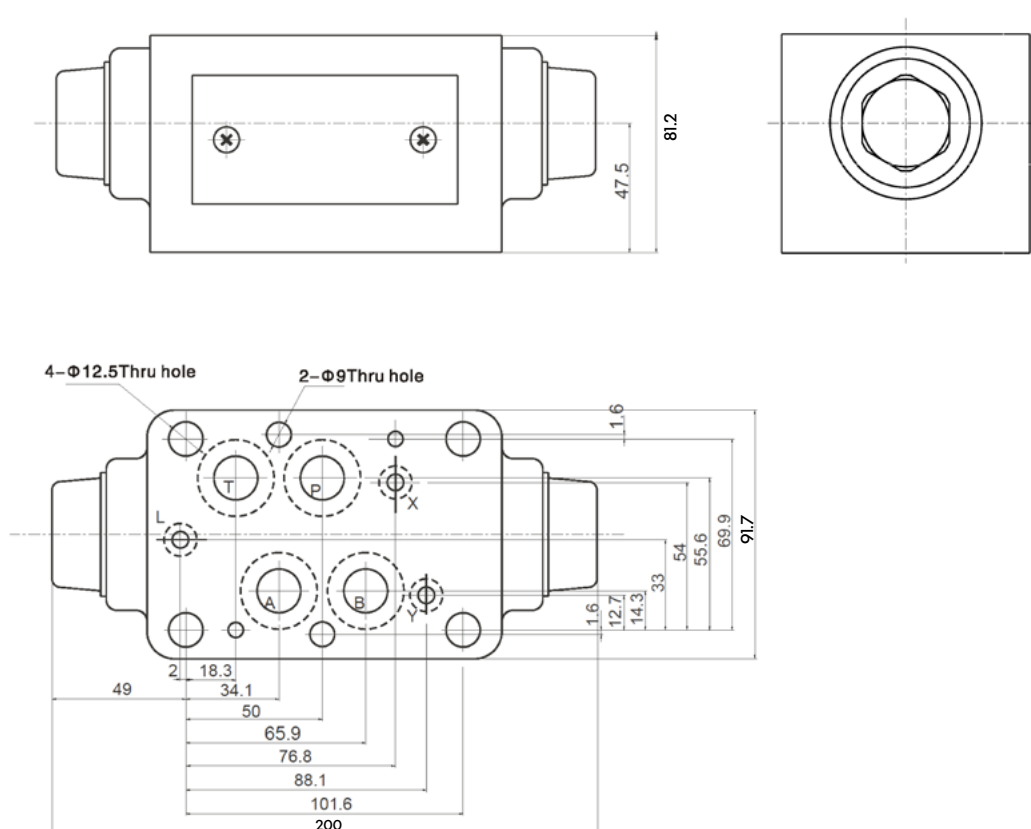

Modular pilot-operated check valve

Cetop 8 / NG25

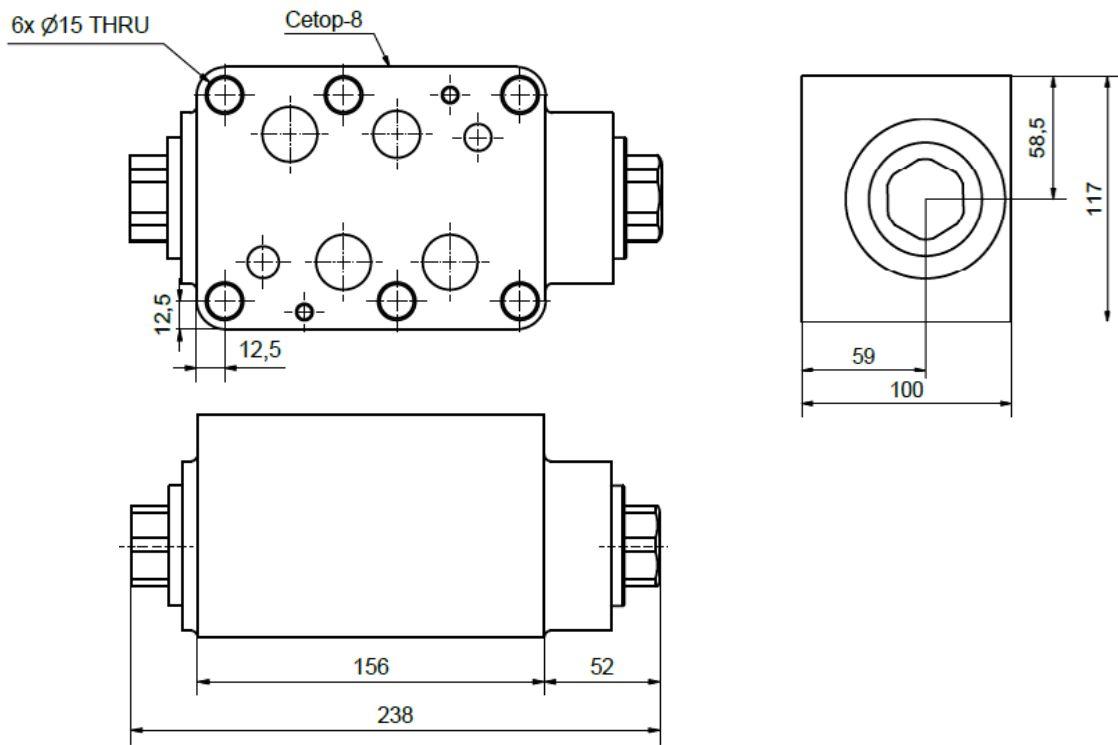

Modular overcenter valve



KOOV series modular Modular
Cetop free flow in one direction
and block flow in the counter
direction.

Technical Specification

Specification	Cetop 3 / NG6
Max. working pressure (MPa)	350
Max. Flow (L/min)	50
Working fluid	Mineral oil: phosphate-ester
Fluid temp. (°C)	-20~70
Viscosity (mm ² /s)	2.8~500
O penning pressure	a: 0.05 b: 0.25 c: 0.4

Cleanliness

The maximum allowable cleanliness of the oil should be according to 9th degree of Standard NAS1638. It is suggested that the minimum filter rating should be $\beta_{10} \geq 75$.

Ordering Code

KOOV-6-*-**

Modular Cetop

Nominal size 6 Cetop 3

A A Pipeline

B B Pipeline

W AB Pipeline

Seal Material
Omit NBR Seals
V FPM Seals

O penning pressure
a 0.05
b 0.25
c 0.4

Code Symbol

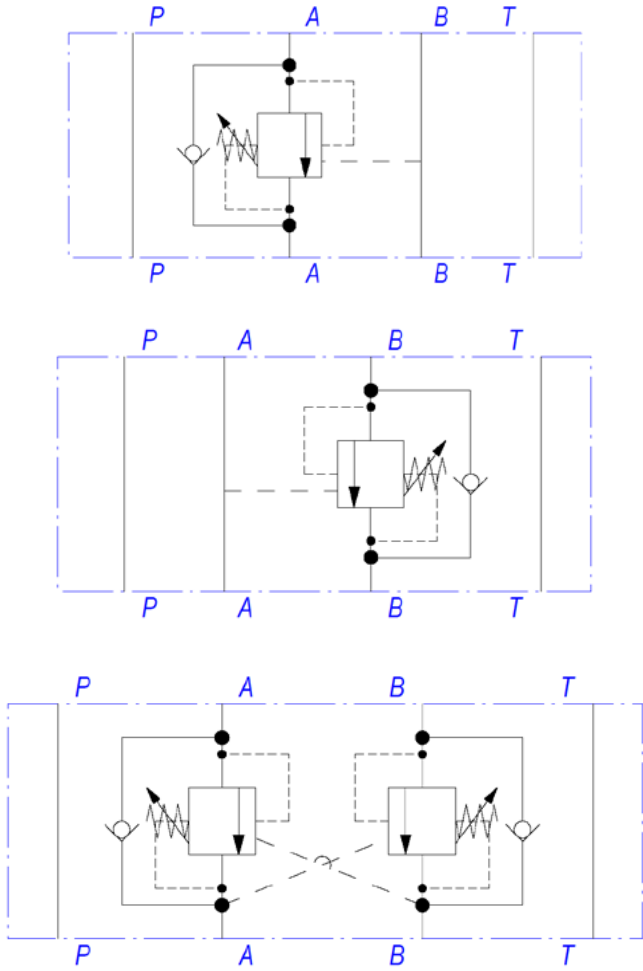

External Dimensions

Simple

Cetop 3

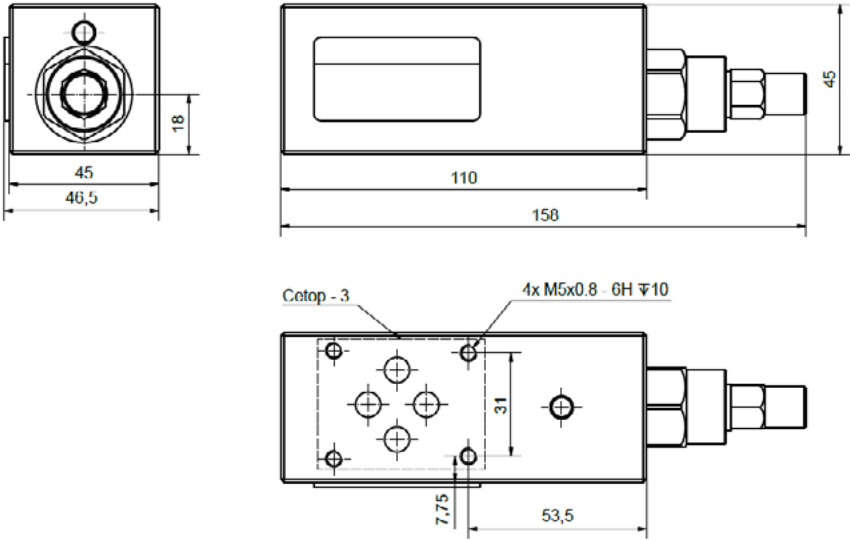

Cetop 5 / NG10

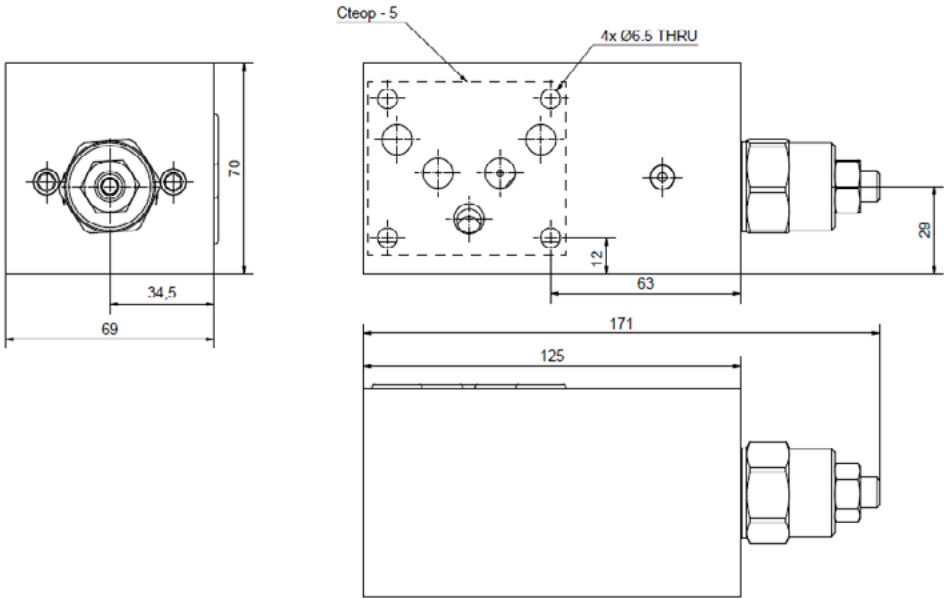

Modular overcenter valve

Double

Cetop 3 / NG6

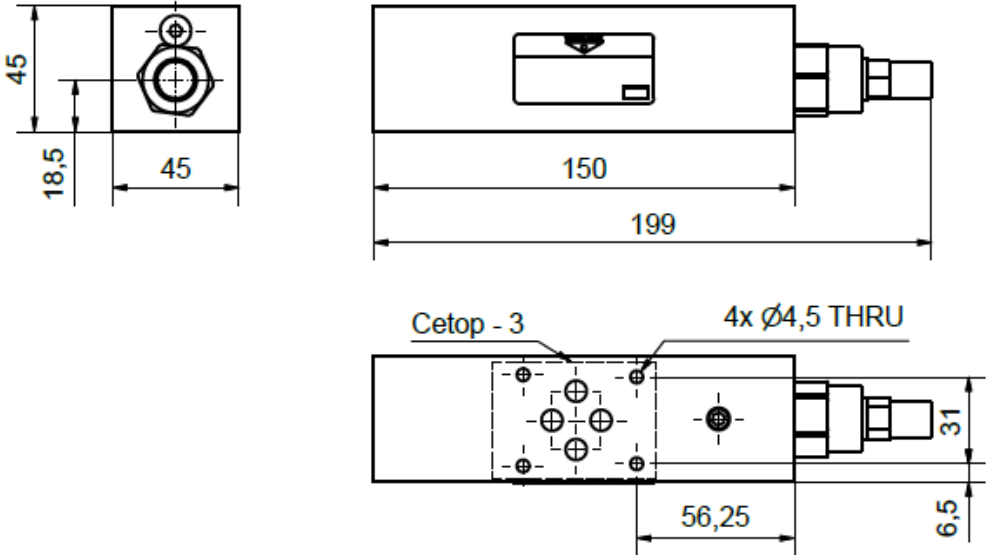

Cetop 5 / NG10

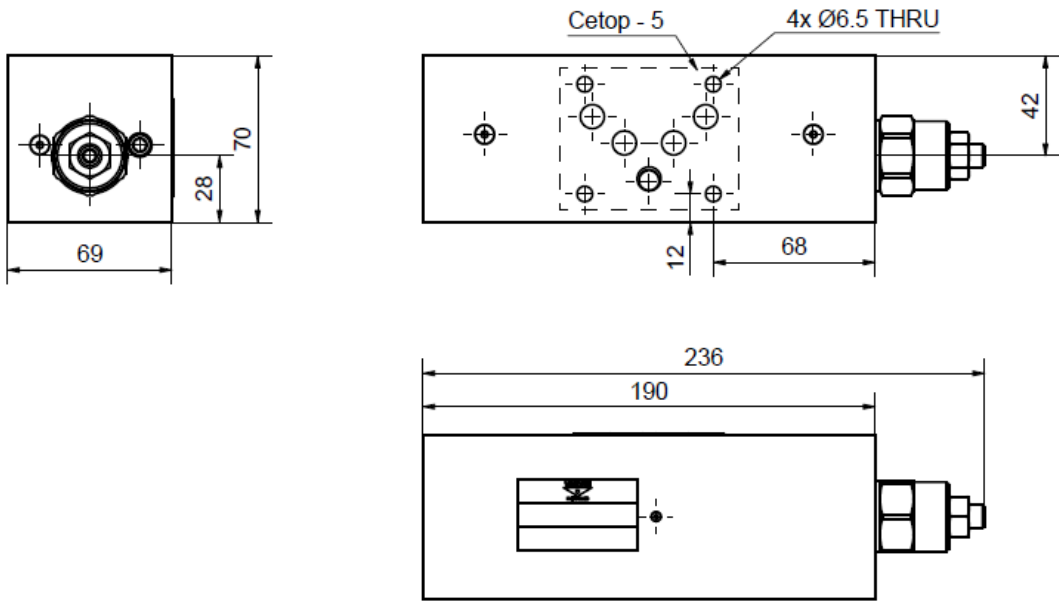

Electrical check valve

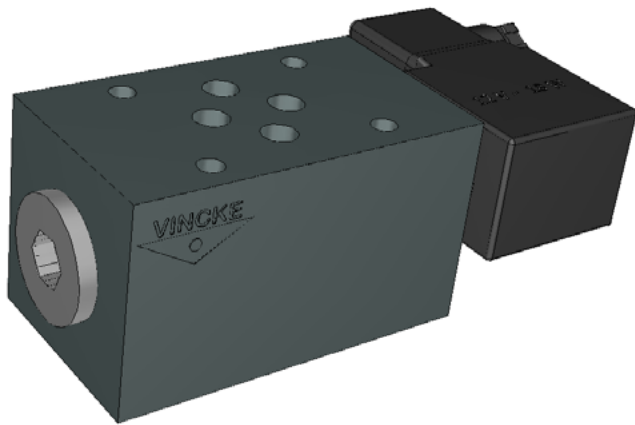

ECV series modular Electric check valve free flow in one direction and block flow in the counter direction.

Technical Specification

Specification	Cetop 3 / NG6
Max. working pressure (MPa)	350
Max. Flow (L/min)	50
Working fluid	Mineral oil: phosphate-ester
Fluid temp. (°C)	-20~70
Viscosity (mm ² /s)	2.8~500
O penning pressure	a: 0.05 b: 0.25 c: 0.4

Cleanliness

The maximum allowable cleanliness of the oil should be according to 9th degree of Standard NAS1638. It is suggested that the minimum filter rating should be $\beta_{10} \geq 75$.

Ordering Code

ECV-6-*-**

Electrical Check Valve

Nominal size 6 Cetop 3, 10 Cetop 5,

A A Pipeline

B B Pipeline

W AB Pipeline

Seal Material
Omit NBR Seals
V FPM Seals

O penning pressure
a 0.05
b 0.25
c 0.4

External Dimensions

Cetop 3 / NG6

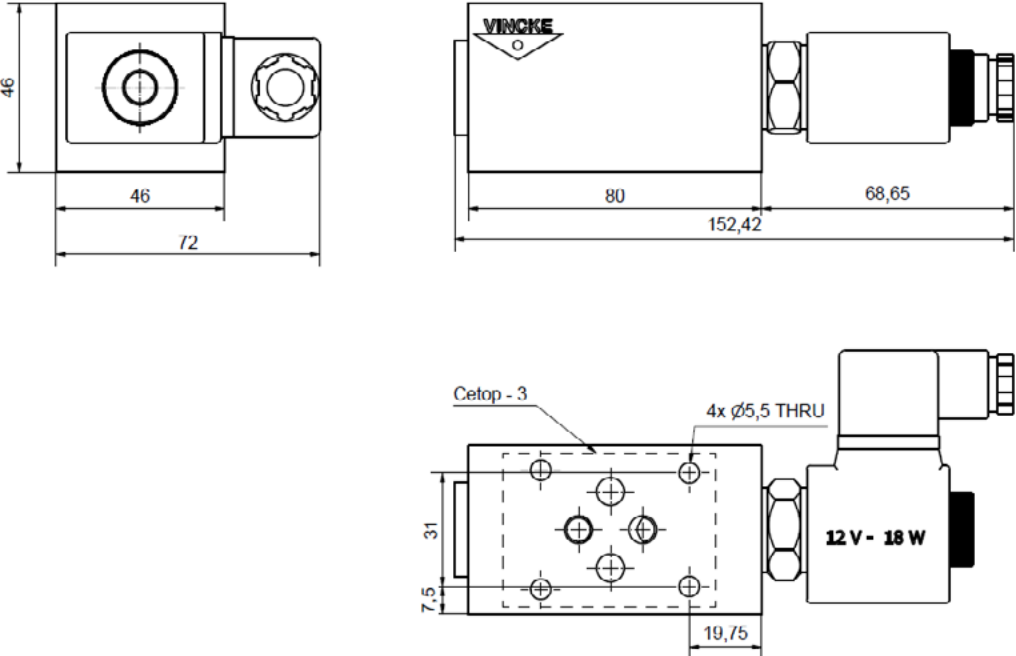

Cetop 5 / NG10

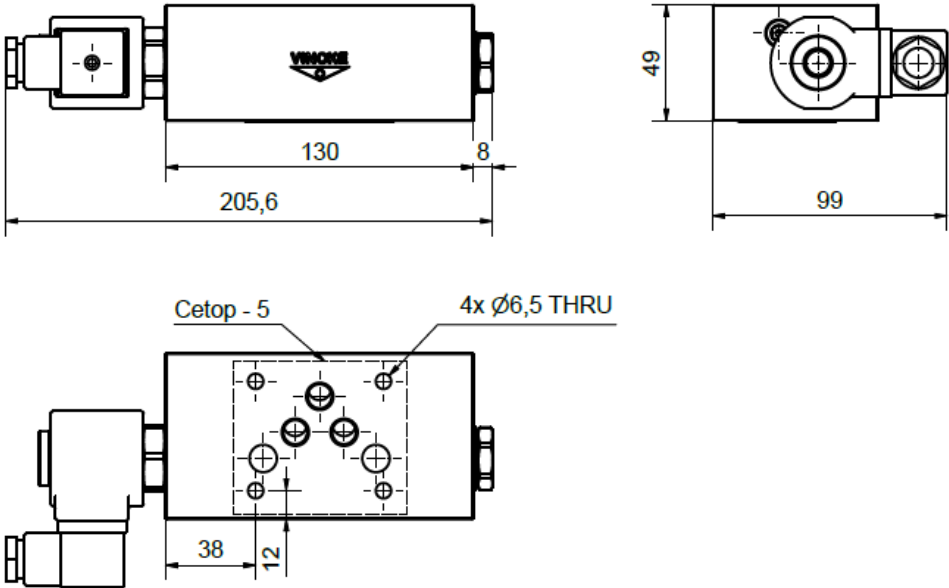

Code Symbol

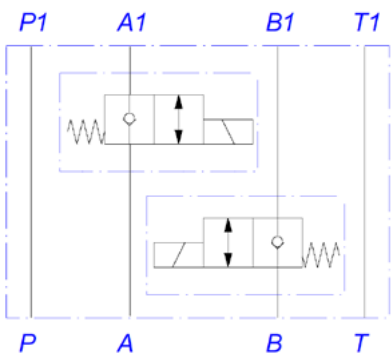
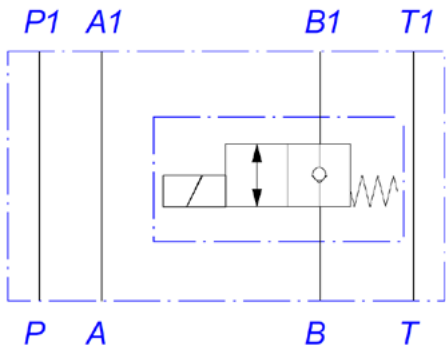
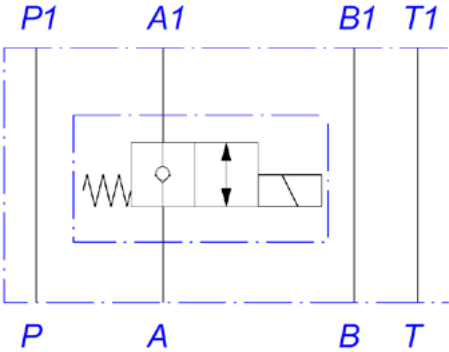

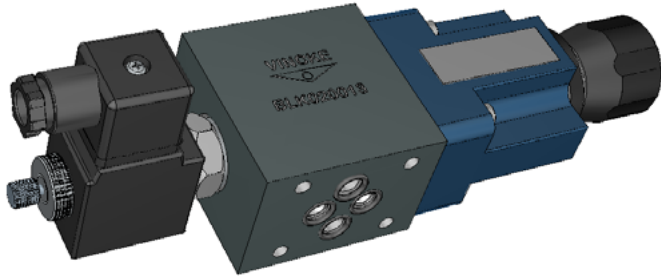

FS series modular Fast-Slow Cetop free flow in one direction and block flow in the counter direction.

Technical Specification

Specification	Cetop 3 / NG6
Max. working pressure (MPa)	350
Max. Flow (L/min)	50
Working fluid	Mineral oil: phosphate-ester
Fluid temp. (°C)	-20~70
Viscosity (mm ² /s)	2.8~500
O penning pressure	a: 0.05 b: 0.25 c: 0.4

Cleanliness

The maximum allowable cleanliness of the oil should be according to 9th degree of Standard NAS1638. It is suggested that the minimum filter rating should be $\beta_{10} \geq 75$.

Ordering Code

FS-6--****

Fast-Slow Cetop

Nominal size 6 Cetop 3

A A Pipeline

B B Pipeline

W AB Pipeline

Seal Material
Omit NBR Seals
V FPM Seals

O penning pressure
a 0.05
b 0.25
c 0.4

Code Symbol

FAST-SLOW NORMALLY CLOSE LINE A

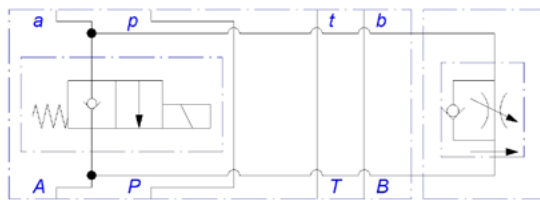

OR SIDE

FAST-SLOW NORMALLY CLOSE LINE B

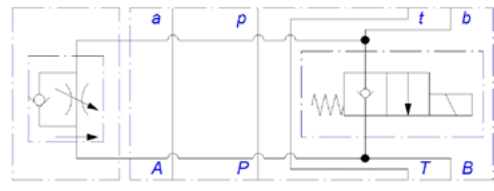

OR SIDE

FAST-SLOW NORMALLY CLOSE LINE P

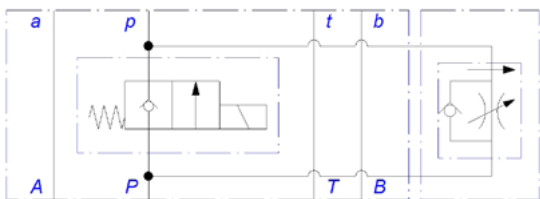

OR SIDE

FAST-SLOW NORMALLY CLOSE LINE T

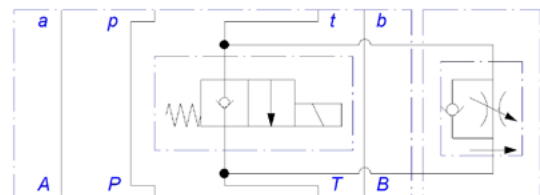

OR SIDE

FAST-SLOW NORMALLY OPEN LINE A

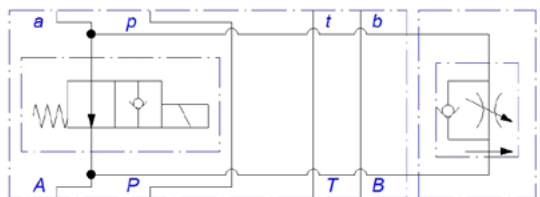

OR SIDE

FAST-SLOW NORMALLY OPEN LINE B

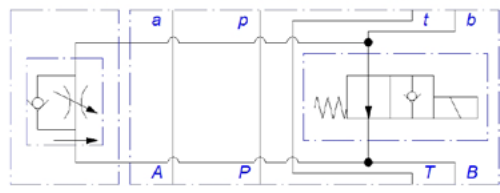

OR SIDE

FAST-SLOW NORMALLY OPEN LINE P

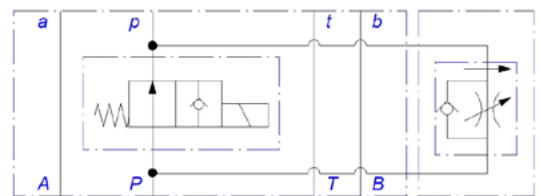

OR SIDE

FAST-SLOW NORMALLY OPEN LINE T

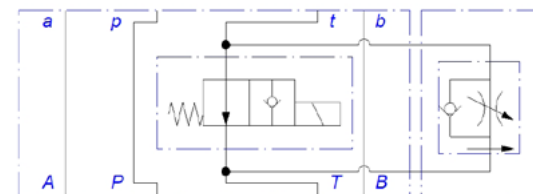

OR SIDE

External Dimensions

Cetop 3 / NG6

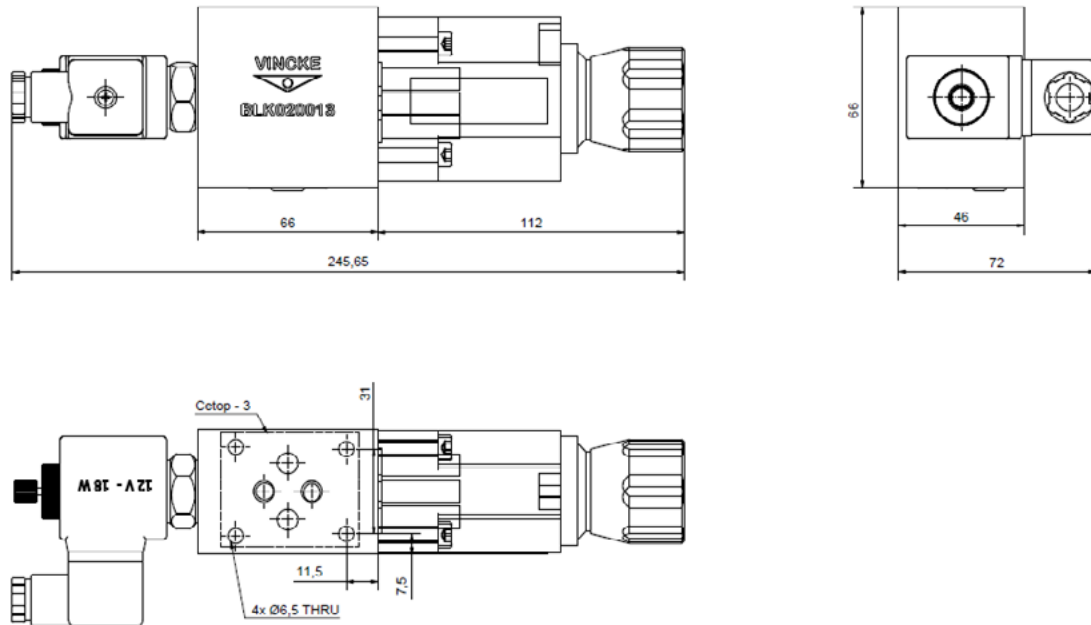



Technical Specification

Specification		Cetop 3 / NG6									
2-way flow control valve		Mineral oil (HL, HLP) wit DIN51524; organic phosphate (HFD-R)									
Fluid											
Temperature range of oil (°C)		-20~+80									
Cleanness of oil		The highest pollution grade of oil NAS1638 grade 9, advise the filtration of filter to be $\beta_{10} \geq 75$									
Flow	Q max (L/min)	0.2	0.6	1.5	3.0	6.0	10.0	16.0	25.0	32.0	
	Q min to 10MPa (ML/min)	15	15	15	15	25	50	70	100	250	
	~31.5MPa (ML/min)	25	25	25	25	25	50	70	100	250	
The pressure drop ΔP , when B \rightarrow A flow reversely-freely		see the back curve									
Minimum differential pressure (MPa)		0.6~1.4									
Pressure stability, to $\Delta P=31.5\text{MPa}$ (%)		$\pm 2(Q_{\max})$									
Working pressure, port A (MPa)		~31.5									
Weight (Kg)		To 1.3 (SB ~ 1.5)									
Rectifier stack board											
Nominal flow rate (L/min)		32									
Start Pressure (MPa)		~21									
Weight (Kg)		about 0.9									

Under the small flow, when flow from P (entrance of directional valve) to A (exit of flow control valve), the pressure loss is substantial.

Ordering Code

KFRC-6-7-6-3-V-*

Flow control valve

Nominal size 6 Cetop 3

Setting device

Scale knob can be locked=3

With scale knob= 7

When scale is at 0 position, it corresponds to Port= 6

Explain other details with words

1.V=FKM seal
No mark= NBR seal

- 1.Flow (A → B)
- 0.2Q=to 0.2L/min
- 0.6Q=to 0.6L/min
- 1.5Q= to 1.5L/min
- 3Q= to 3L/min
- 6Q= to 6L/min
- 10Q= to 10L/min
- 16Q= to 16L/min
- 25Q= to 25L/min
- 32Q= to 32L/min

Hydraulic Symbol

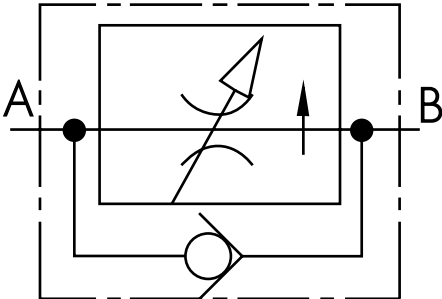

Characteristic Curve

(measured when $v=36\text{mm}^2/\text{s}$; $t=50^\circ\text{C}$)

curve of flow-scale (flow control A \rightarrow B)

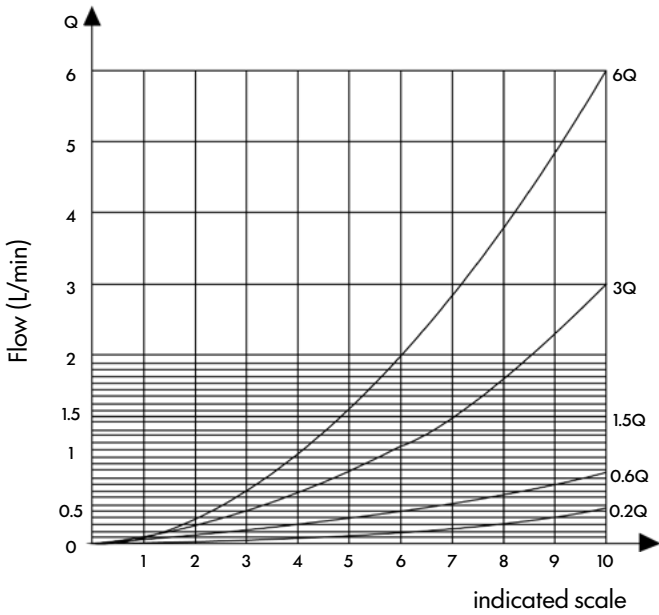
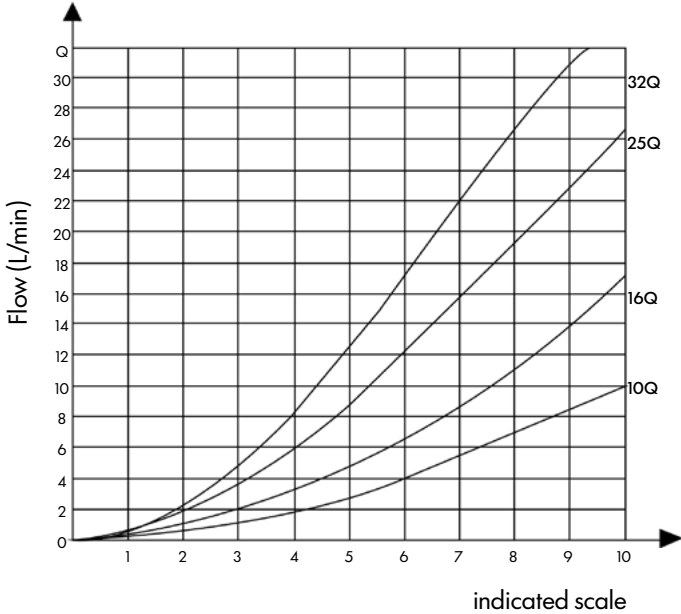

Flow Control Valve

Choke orifice closed, the differential pressure goes by one-way valve from B to A

Curve of pressure and flow

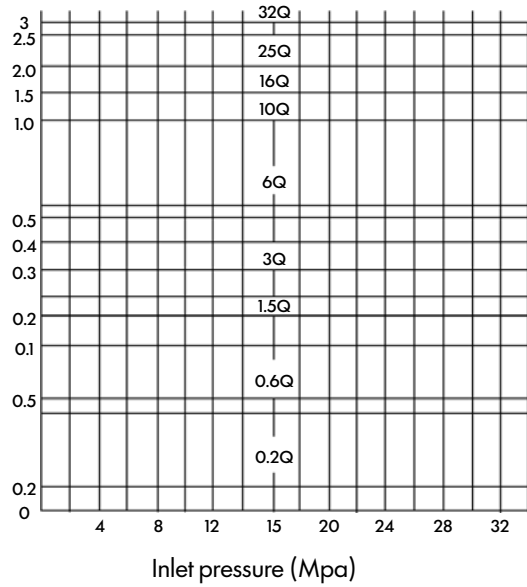
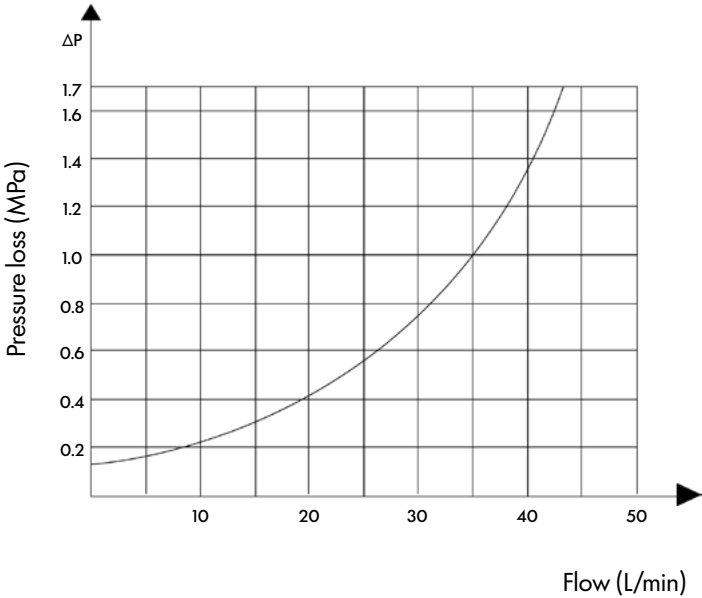

The effect from temperature when $\Delta P=2\text{Mpa}$

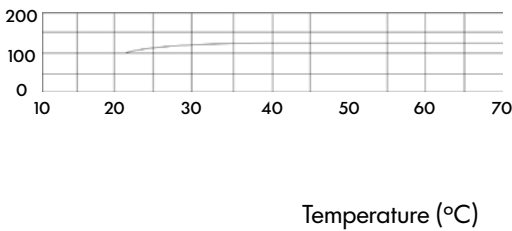
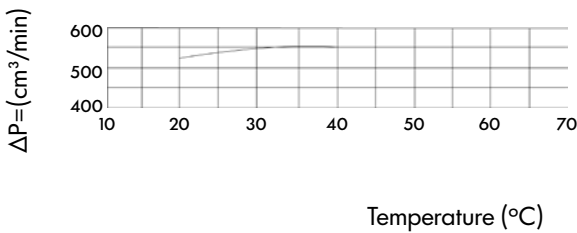
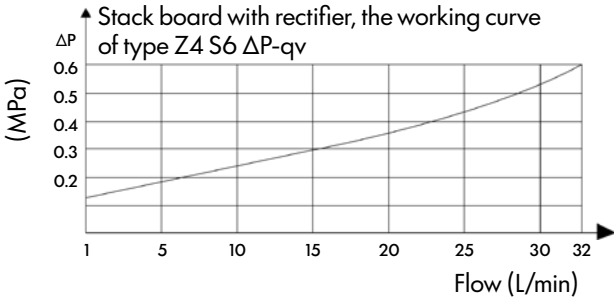
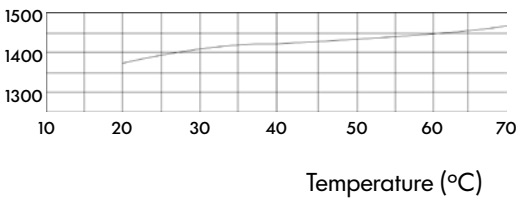

External Dimensions

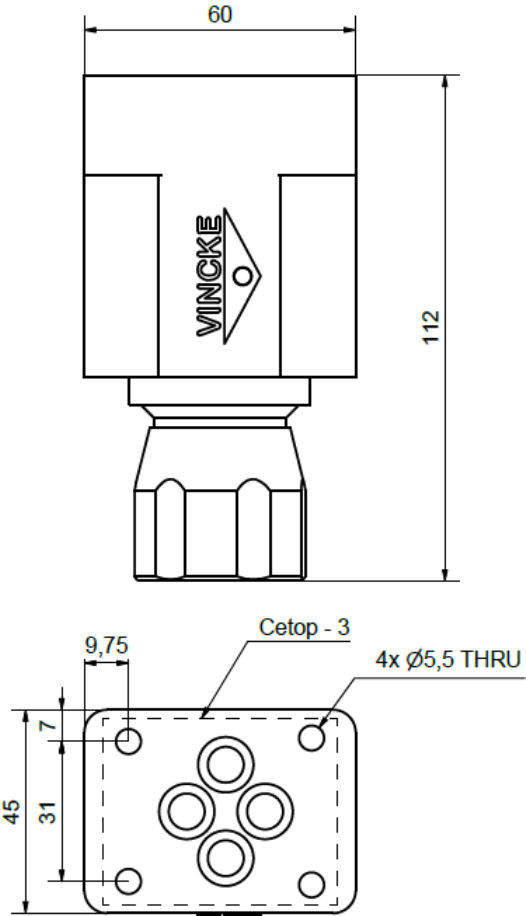

RELIEF VALVE

Pág 87

UNLOADING VALVE

Pág 92

VINCKE
HYDRAULICS

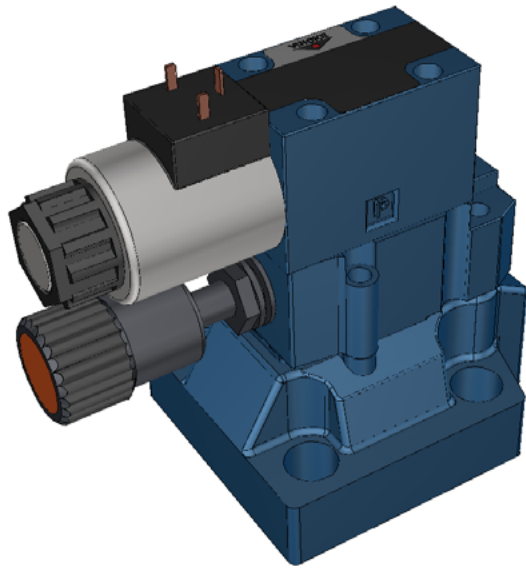

Technical Specification

Specification	Cetop 3 / NG6		Cetop 5 / NG6	
	10	15	20	25
Max Flow (L/min)	250	500	500	500
Max. working pressure (MPa)	35			
Working fluid	Mineral oil: phosphate-ester hydraulic oil			
Fluid Temp (C°)	-20~70			
Viscosity (Mm ² /s)	12~380			
Working press (MPa)	5	10	20	31.5 35

Cleanliness

The maximum allowable cleanliness of the oil should be according to 9th degree of Standard NAS1638. It is suggested that the minimum filter rating should be $\beta_{10} \geq 75$.

Ordering Code

DAM--10-**-B-1-Y*-DC24-**-**-****

Relief valve	Seal Material omit NBR V FPM
Omit with solenoids directional valve W Without solenoids directional valve	Pilot operated drainage port thread Omit G1/4" 2 M14X1.5
Omit Pilot operated valve C Pilot operated without main cartridge (not marked diameter) Pilot operated with main cartridge (marked diameter)	Omit no damping ²⁾ 08 0.8 Damping 10 1.0 Damping 12 1.2 Damping
Nominal size 10-20	Omit whitout push road emergency ³⁾ N9 with concealed push road emergency
Omit Subplate connection G Pipe type connection-G Scew G2 Pipe type connection-M Scew	Z5L Square connector with light ⁴⁾
Working pressure 5 to 5MPa 10 to 10MPa 20 to 20MPa 31.5 to 31.5MPa 35 to 35MPa	Working voltage ⁵⁾ D12 DC12V D24 DC24V A110 AC110V A220 AC220V B110 (B110V Rectifield) B220 (B220V Rectifield)
A Always close B Always open	Omit Standard Type ⁶⁾ U minimum setting pressure is lower type
1 Rotary knob 2 Sleeve with hehagon and protective cap	Omit Intl cntrl intl disch X Extl cntrl intl disch Y Intl cntrl extl disch XY Extl cntrl extl disch

Code Symbol

Y...

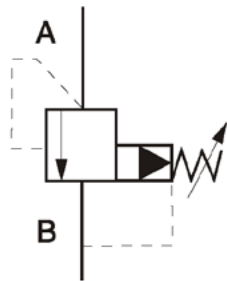

Y..X/..

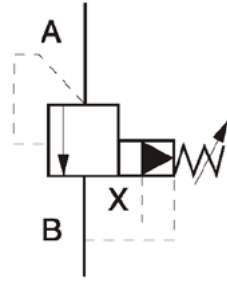

Y..Y/..

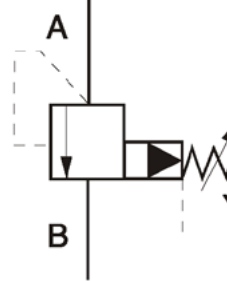

Y..XY/..

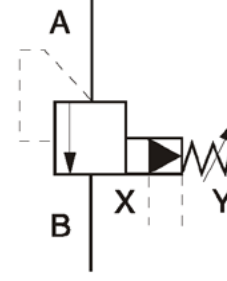

YW..
Always close

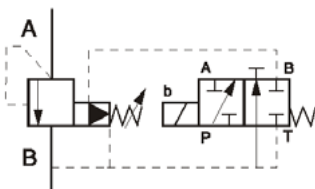

YW..X/
Always close

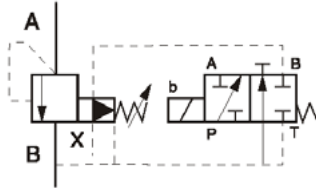

YW..Y/
Always close

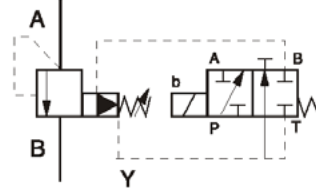

YW..XY/
Always close

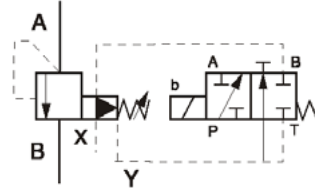

Always open

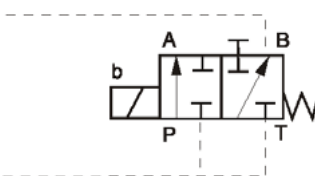

Always open

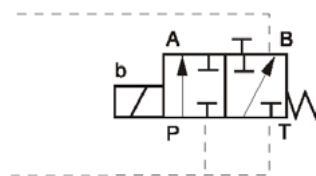

Always open

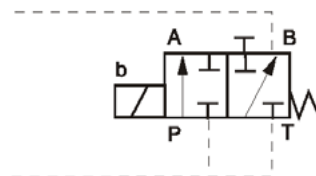

Always open

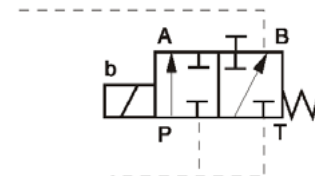

Performance Curve

- 1) The characteristic curves were measured with external, pressureless, pilot oil drain.
- 2) In the case of internal pilot oil drain, the inlet pressure increases by the outlet pressure in port T.

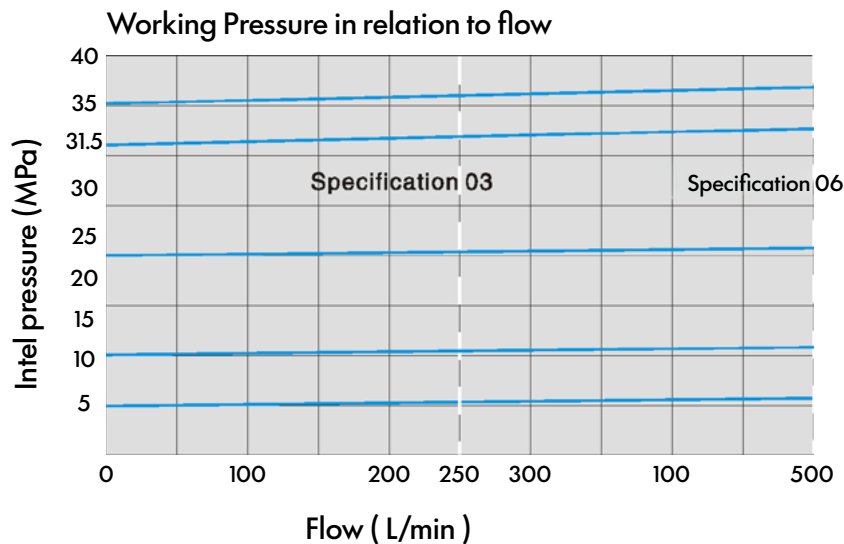

Minimum set pressure and circulation pressure in dependence upon the flow standard version.

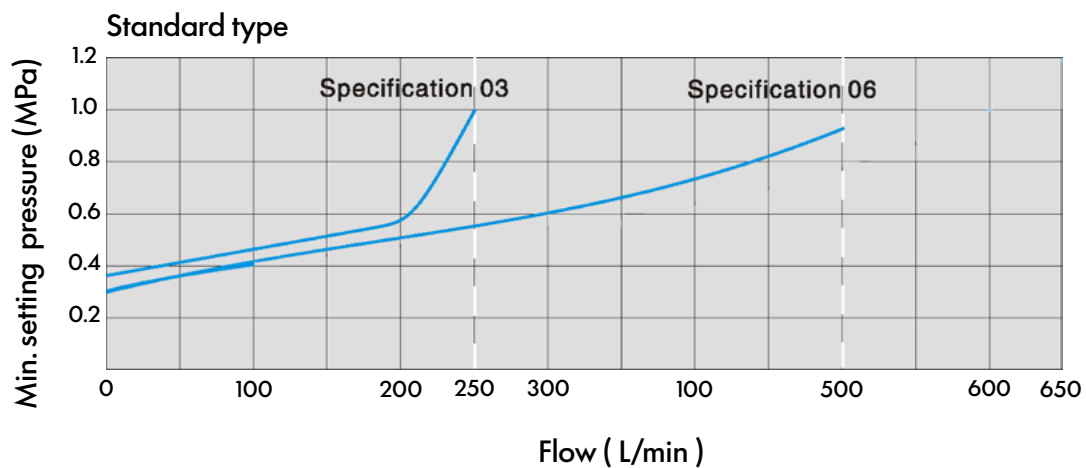

Minimum set pressure and circulation pressure in dependence upon the flow version "u"

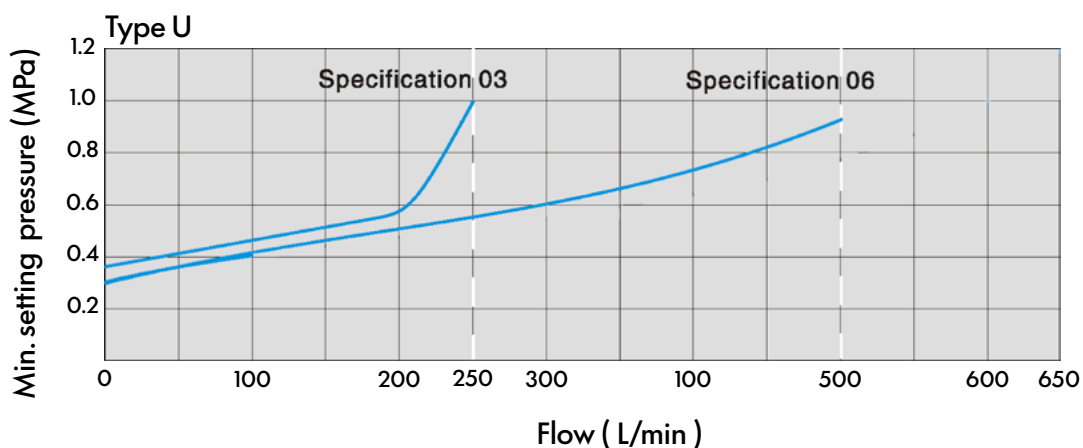

The characteristic curves are valid for outlet pressure B:O over the entire flow range.

External Dimensions

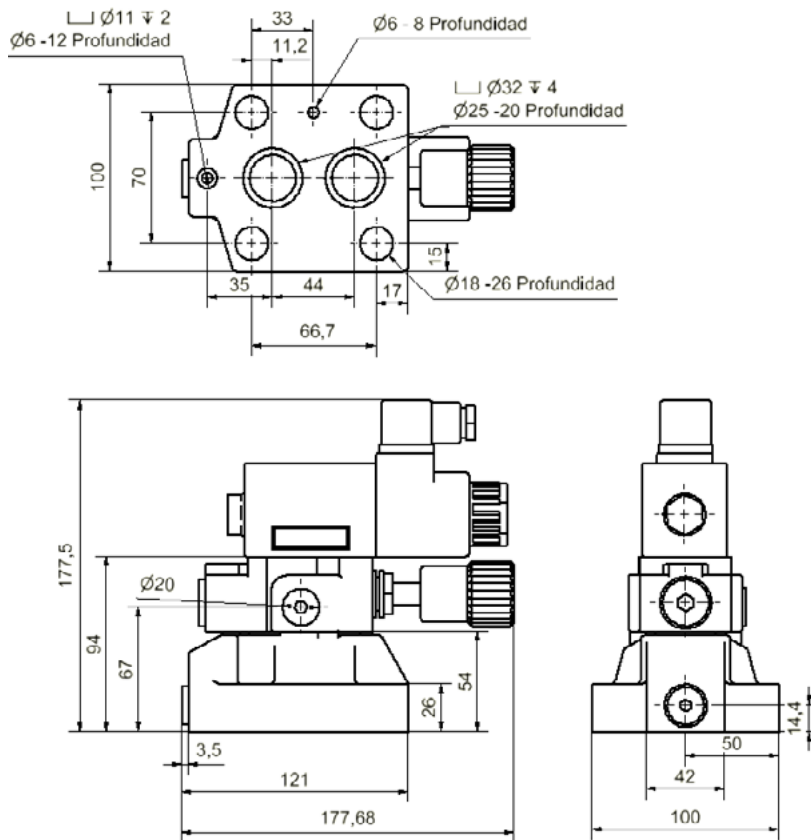

Subplate Mounting Size

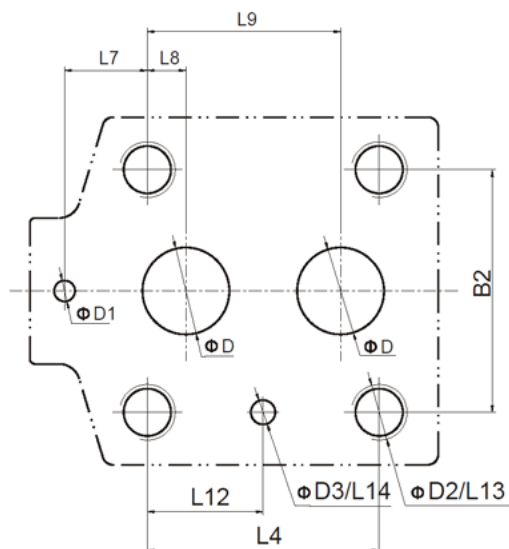

Specification	Mounting screw	Tighten torque
Y/YW-03	M12x45-10.9	130Nm
Y/YW-06	M16x50-10.9	310Nm

Specification	B1	B2	L1	L2	L3	L4	L5	L6	L7	L8	L9	L10	L11	L12	L13	L14	D	D1	D2	D3
Y/YW-03	77.9	54	95	90	67	54	23.5	149.3	0	22.1	47.5	14	159.7	22.1	20	5	12	6	M12	7
Y/YW-06	100	69.8	122.2	117.5	83.7	66.7	26.5	161.8	23.8	11.1	55.6	11	172.2	33.3	25	6	25	6	M16	7

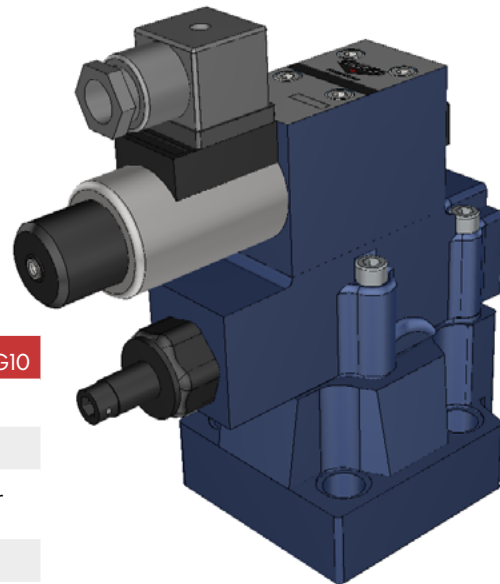

Technical Specification

Specification	Cetop 3 / NG6	Cetop 5 / NG10
Max. working pressure (MPa)	31.5	
Max Flow (L/min)	250	500
Working fluid	Mineral oil: phosphate-ester hydraulic oil	
Fluid Temp (C°)	-20~70	
Viscosity (Mm ² /s)	12~380	
Working press (MPa)	5 10 20	31.5 35

Cleanliness

The maximum allowable cleanliness of the oil should be according to 9th degree of Standard NAS1638. It is suggested that the minimum filter rating should be $\beta_{10} \geq 75$.

Ordering Code

DIU--10-***-Y-**-***

Sequence valve

Pilot operated valve
 Omit Pilot operated without main cartridge
 (not marked diameter)
 C Pilot operated with main cartridge
 (marked diameter)

Nominal size 10-20

Working press
 5 to 5MPa
 10 to 10MPa
 20 to 20MPa
 31.5 to 31.5MPa
 35 to 35MPa

Omit Without check valve
 D With check valve

Seal Material
 omit NBR
 V FPM

Pilot operated drainage port thread
 Omit G1/4"
 2 M14X1.5

Omit Intl cntrl intl disch
 X Extl cntrl intl disch
 Y Intl cntrl extl disch
 XY Extl cntrl extl disch

1 Rotary knob
 2 Sleeve with hexagon and protective cap

Code Symbol

YS..

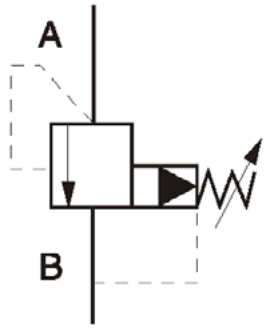

YS..X/..

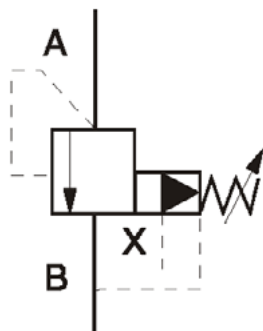

YS..Y/..

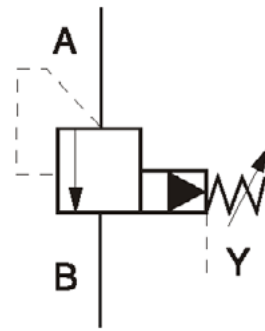

YS..XY/..

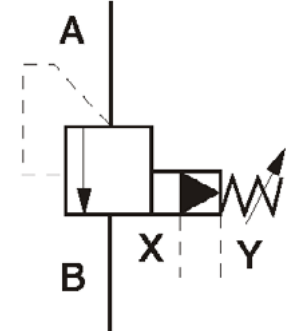

YS..D..

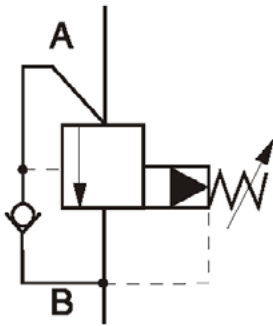

YS..D..X/..

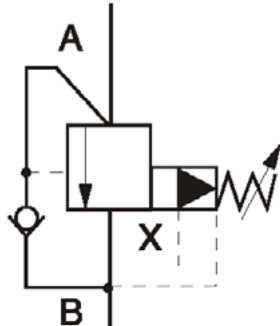

YS..D..Y/..

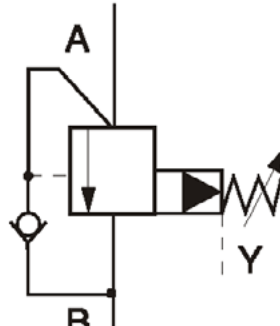

YS..D..XY/..

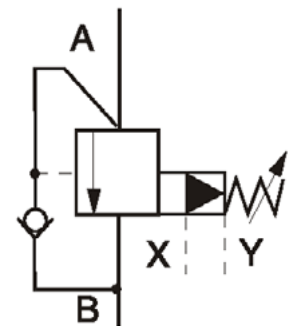

Performance Curve

Intel pressure in relation to the flow (A → B)

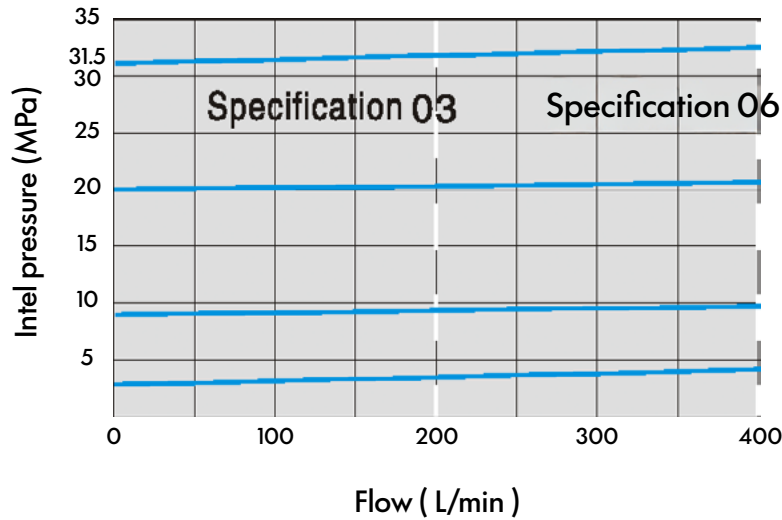

Minimum settable pressure in relation to the flow (A → B)
(=bypass pressure version "...X...")

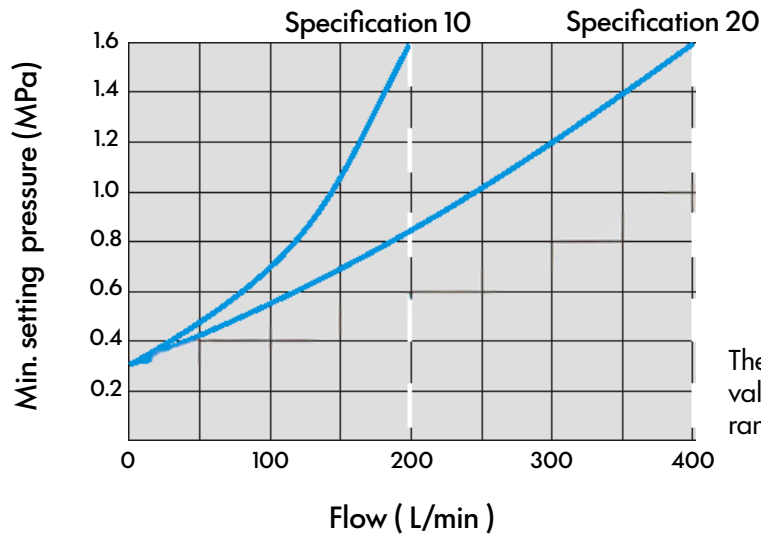

The characteristic curve are valid for the complete flow range

Bypass pressure in relation to (A → B)
(only version "...XY...")

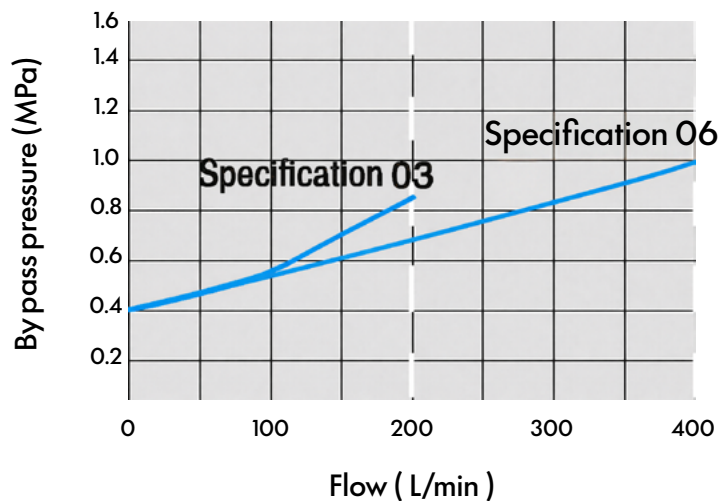

The characteristic curves are valid for outlet pressure $P_B = 0$ for the complete flow range

Unloading Valve

The curve ΔP -Q pass through the check valve

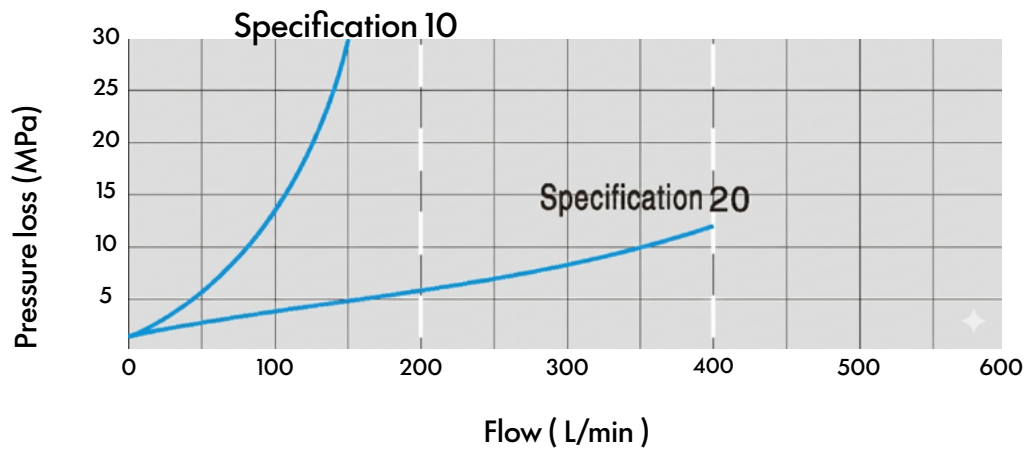

External Dimensions

Cetop 3 / NG6

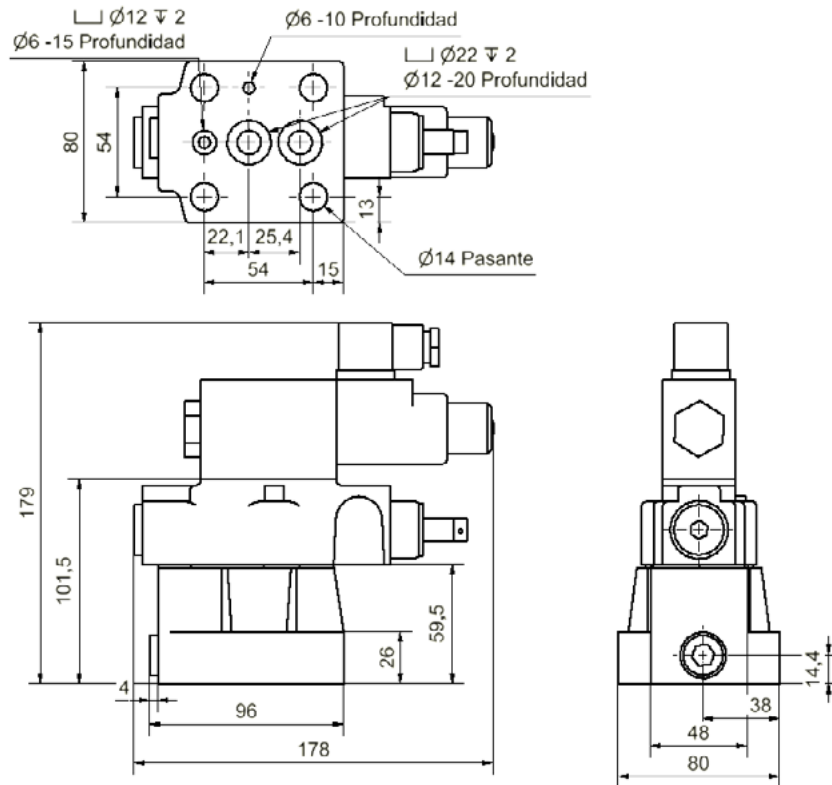

Cetop 5 / NG10

