

# IN-LINE VALVES

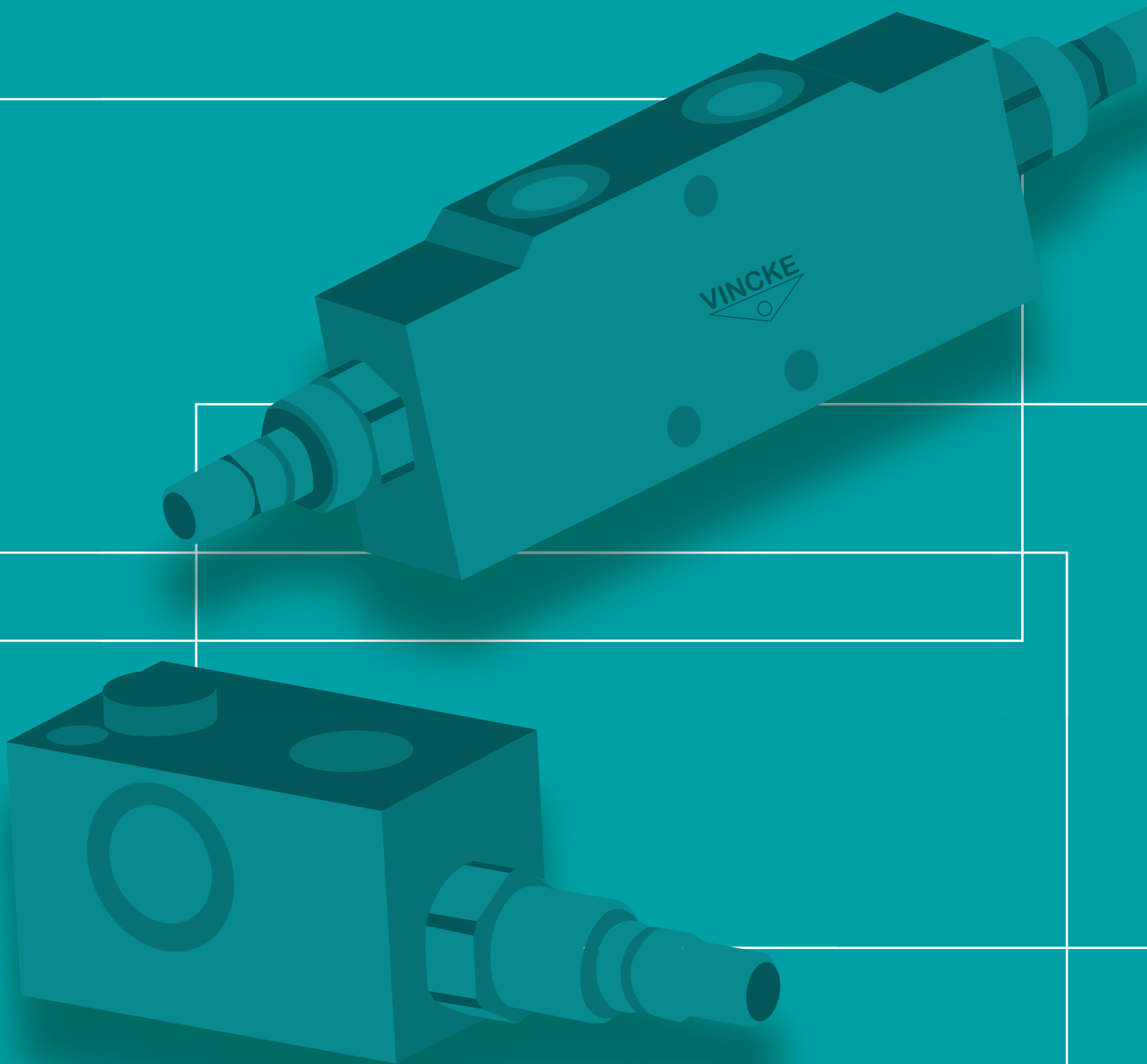

# VINCKE

# INDEX

RELIEF VALVES.....	4
SOLENOIDS VALVES .....	9
COILS.....	13
CHECK VALVES .....	15
HOSE BURST VALVES .....	21
FLOW CONTROL VALVES .....	22
LOAD CONTROL VALVES .....	31
SEQUENCE VALVES.....	34
SHUTTLE VALVES.....	35
DIRECTIONAL VALVES .....	36
END STROKE .....	41
MOTOR VALVES.....	42
FLOW DIVIDERS.....	44



**Vincke** offers a wide range of hydraulic valves for all industrial applications. We manufacture all types of hydraulic valves: from directional control valves to pressure control, flow control, shuttle, sequence, check, from standard on/off valves to high-dynamic proportional valves. Common to all is the combination of outstanding reliability and cost efficiency which makes them the appropriate solution for almost any operational purpose.

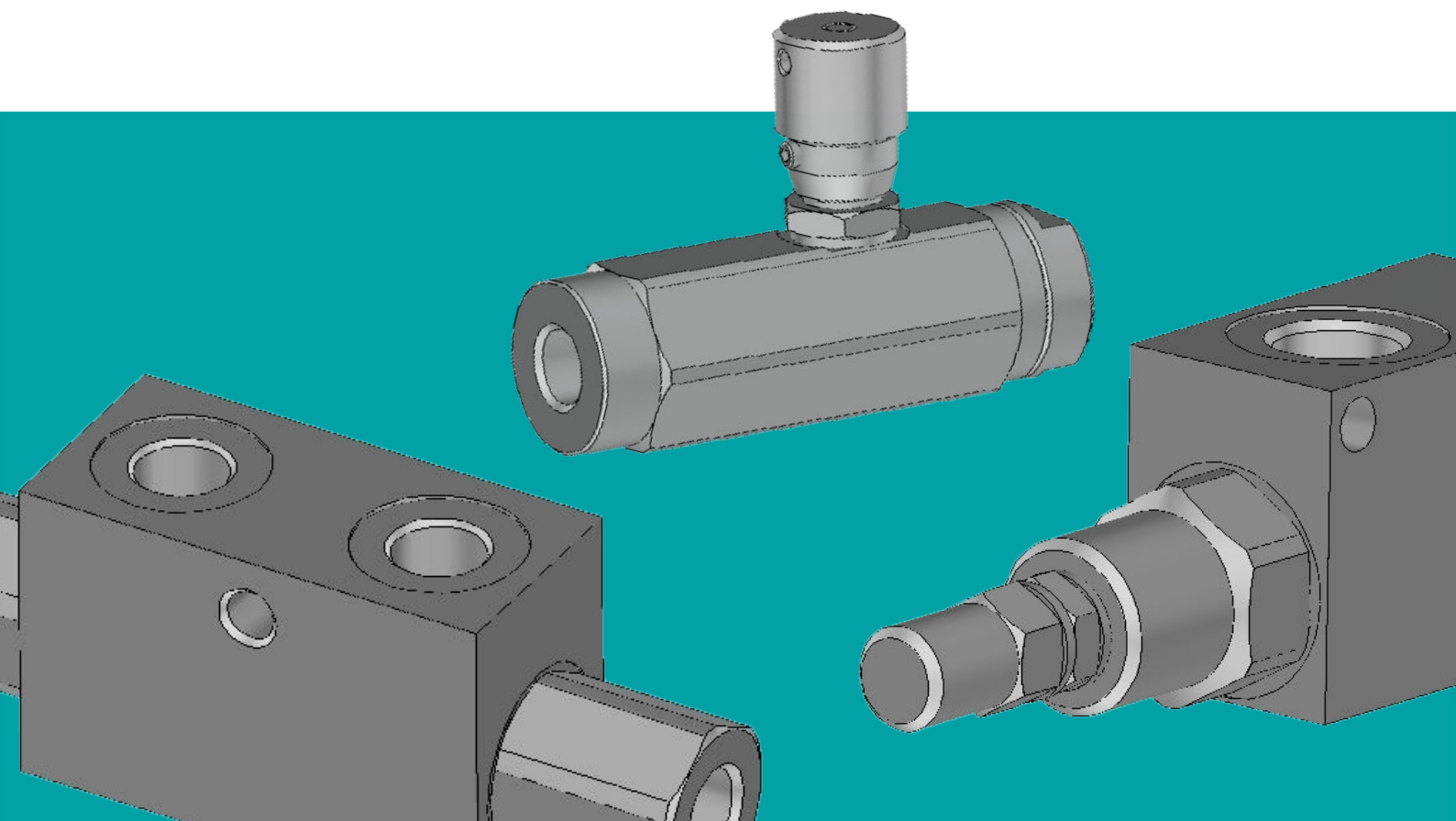

## IN-LINE PANEL MOUNTING RELIEF VALVES

### SPECIFICATIONS

Fluid viscosity:	30 - 100 mm <sup>2</sup> /s
Filtration:	25 $\mu$
Ambient temperature:	40°C
Fluid temperature:	-20°C + 75°C
Ambient temperature:	-20°C + 50°C

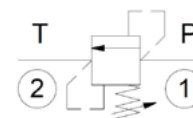

### DIMENSIONS (mm)

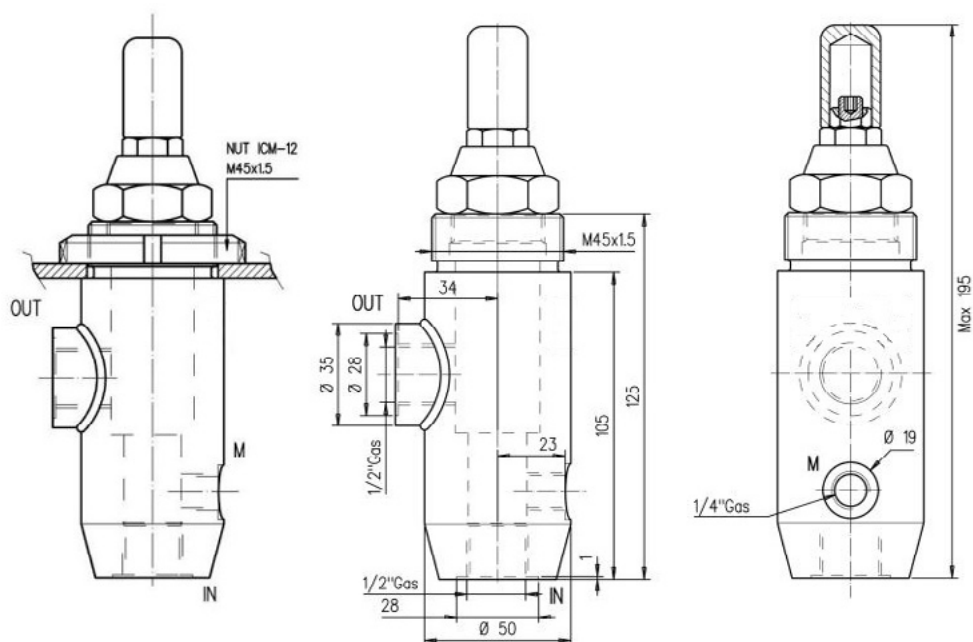

Standard code	Thread	Q max (l/min)	Pressure	Weight (kg)
K-DRLVBH-20	1/2	50	3 - 20	2
K-DRLVBH-80	1/2	50	10 - 80	2
K-DRLVBH-160	1/2	50	60 - 160	2
K-DRLVBH-280	1/2	50	100 - 280	2
K-DRLVBH-320	1/2	20	100 - 320	2

## RELIEF VALVES

### SPECIFICATIONS

Fluid viscosity:	ISO 3448
Filtration:	ISO 4406
Fluid temperature:	-20°C + 90°C
Ambient temperature:	-20°C + 50°C
Max. operating pressure:	350 Bar
Standard seals:	NBR
Manifold material:	Zinc plated steel

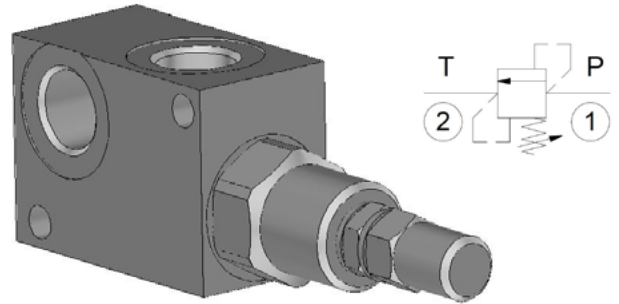

### DIMENSIONS (mm)

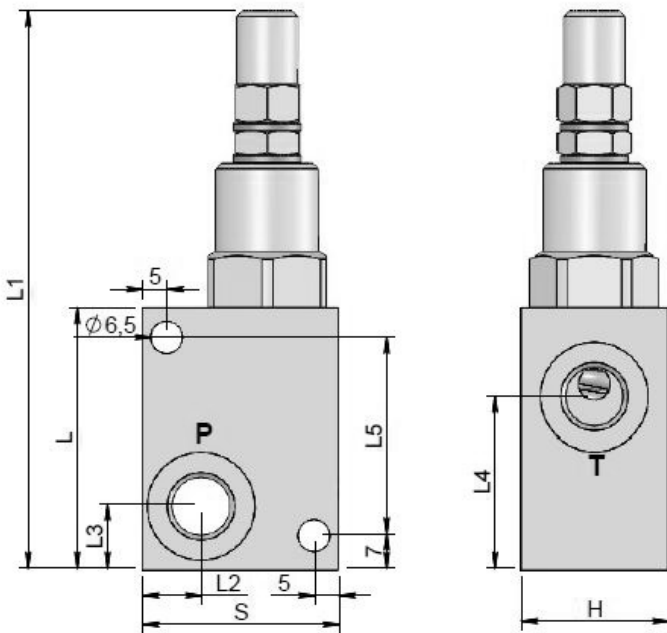

### PERFORMANCE

Oil viscosity 24 mm<sup>2</sup>/s (3,5 °E) - Temperature 50°C

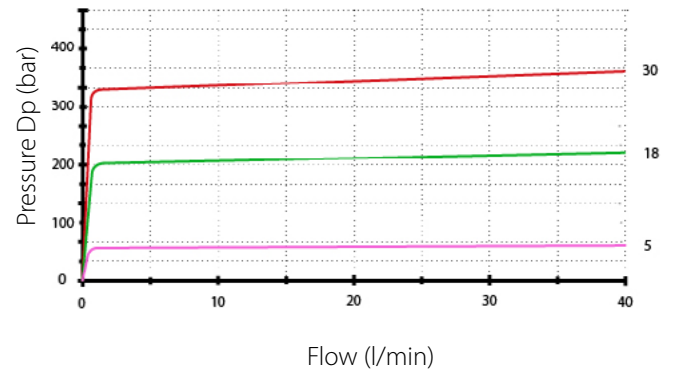

Std setting at 5 l/min

30 = 10 - 50 bar	30 bar
18 = 10 - 180 bar	90 bar
5 = 80 - 300 bar (Std)	150 bar

Standard code	Thread	L	L1	L2	L3	L4	L5	H	S	Weight (kg)	Q max (l/min)
K-DRLV-45	3/8	55	117	12	15	35.5	43	30	40	0.45	40

## RELIEF VALVES

### SPECIFICATIONS

Fluid viscosity:	ISO 3448
Filtration:	ISO 4406
Fluid temperature:	-20°C + 90°C
Ambient temperature:	-20°C + 50°C
Max. operating pressure:	350 Bar
Standard seals:	NBR
Manifold material:	Zinc plated steel

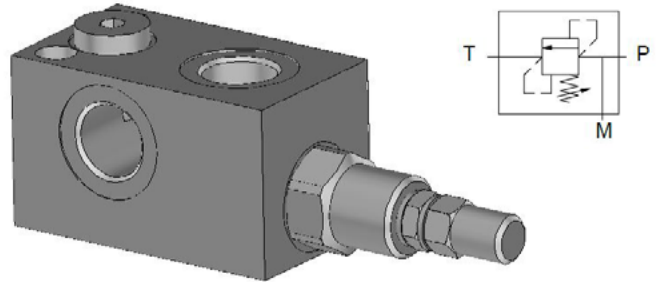

### DIMENSIONS (mm)

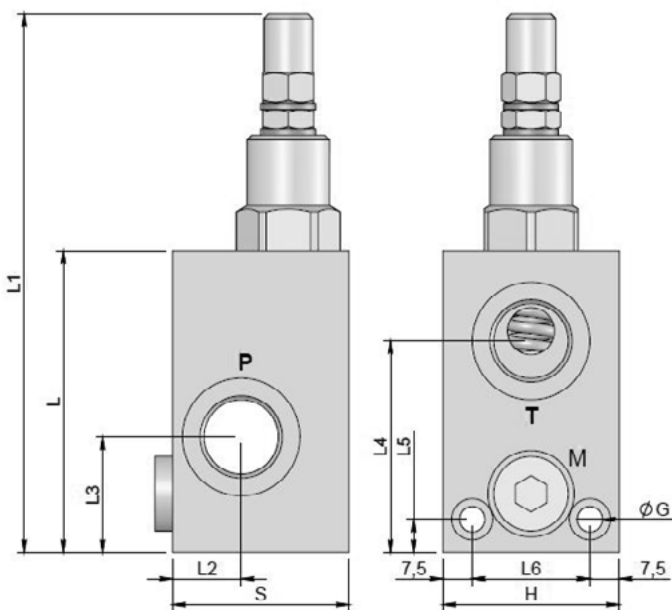

### PERFORMANCE

Oil viscosity 24 mm<sup>3</sup>/s (3,5 °E) - Temperature 50°C

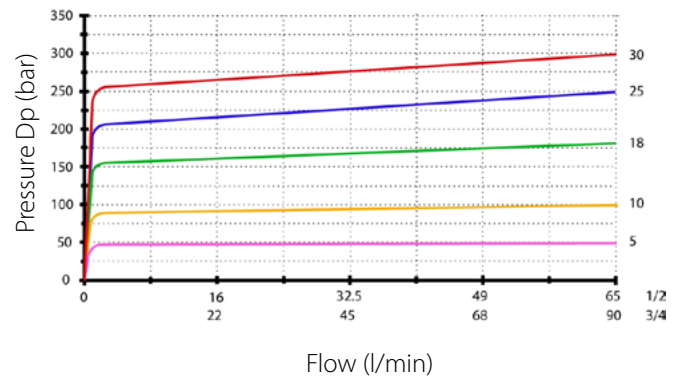

Std setting at 5 l/min

30 = 10 - 50 bar	30 bar
25 = 20 - 100 bar	70 bar
18 = 10 - 180 bar	90 bar
10 = 50 - 250 bar	130 bar
5 = 80 - 300 bar (Std)	150 bar

Standard code	Thread	M	L	L1	L2	L3	L4	L5	L6	G	H	S	Weight (kg)	Q max (l/min)
K-DRLV-70	1/2	1/4	77	139	17.5	29.5	54	8.5	30	6.5	45	45	1.0	70
K-DRLV-100	3/4	1/4	92	154	20	35	68	10	32	8.5	50	50	1.5	90

## RELIEF VALVES

### SPECIFICATIONS

Fluid viscosity:	ISO 3448
Filtration:	ISO 4406
Fluid temperature:	-20°C + 90°C
Ambient temperature:	-20°C + 50°C
Max. operating pressure:	350 Bar
Standard seals:	NBR
Manifold material:	Zinc plated steel

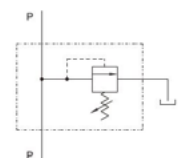

### DIMENSIONS (mm)

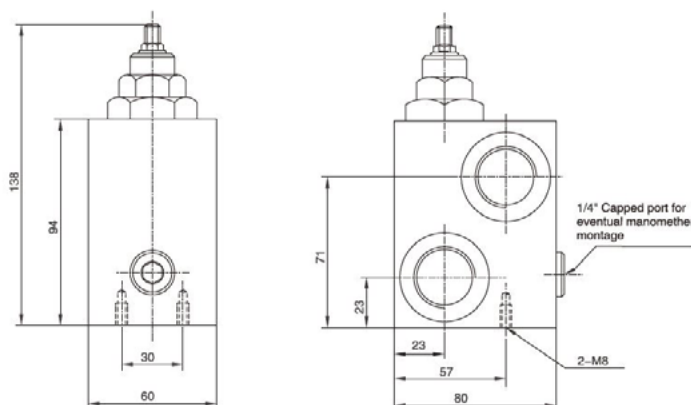

### PERFORMANCE

Oil viscosity 24 mm<sup>3</sup>/s (3,5 °E) - Temperature 50°C

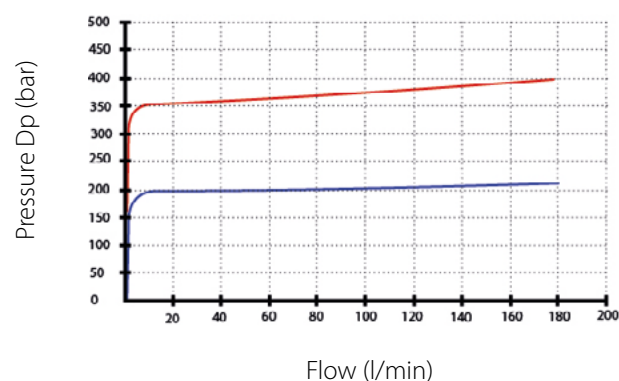

Std setting at 5 l/min

30 = 10 - 50 bar	30 bar
25 = 20 - 100 bar	70 bar
18 = 10 - 180 bar (Std)	90 bar
10 = 50 - 250 bar	130 bar
5 = 80 - 300 bar	150 bar

Standard code	Thread	M	L	L1	L2	L3	L4	L5	L6	G	H	S	Weight (kg)	Q max (l/min)
K-DRLV-180	1"	1/4	77	139	17.5	29.5	54	8.5	30	6.5	45	45	1.0	180

## DOUBLE RELIEF VALVES

### SPECIFICATIONS

Fluid viscosity:	ISO 3448
Filtration:	ISO 4406
Fluid temperature:	-20°C + 90°C
Ambient temperature:	-20°C + 50°C
Max. operating pressure:	350 Bar
Standard seals:	NBR
Manifold material:	Zinc plated steel

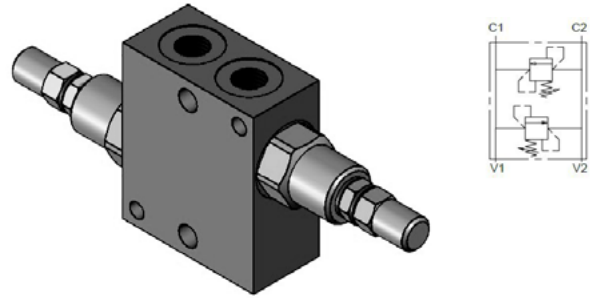

### DIMENSIONS (mm)

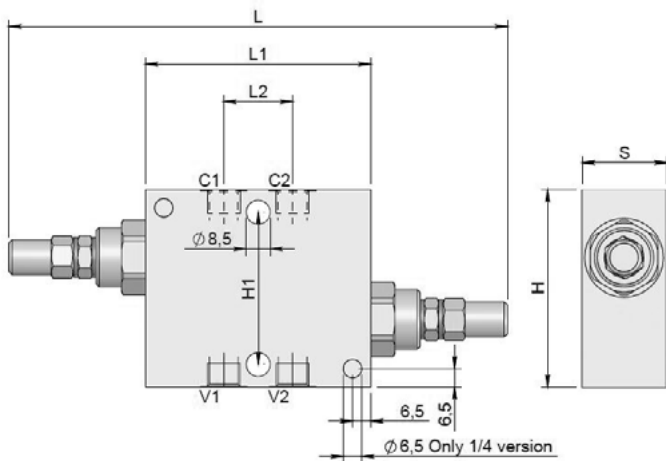

### PERFORMANCE

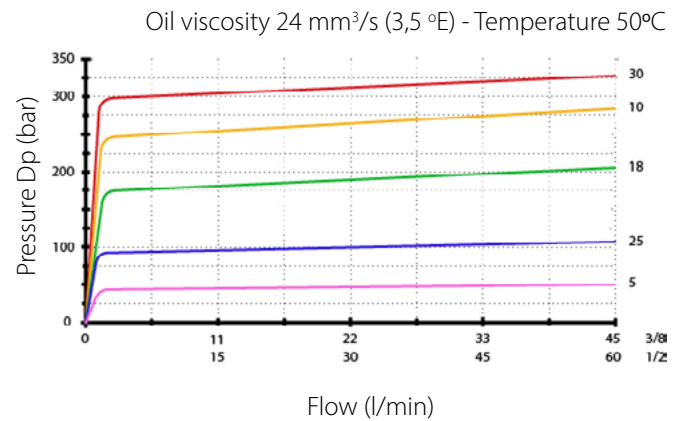

Std setting at 5 l/min

30 = 10 - 50 bar	30 bar
25 = 20 - 100 bar	70 bar
18 = 10 - 180 bar	90 bar
10 = 50 - 250 bar (Std)	130 bar
5 = 80 - 300 bar	150 bar

Standard code	Thread	L	L1	L2	H	H1	S	Weight (kg)	Q max (l/min)
K-DRLVD-45	3/8	176	80	33	70	54	30	1.2	45
K-DRLVD-70	1/2	200	80	38	70	54	30	1.1	70

## 2/2 NORMALLY OPEN

40L

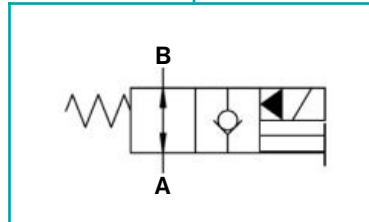
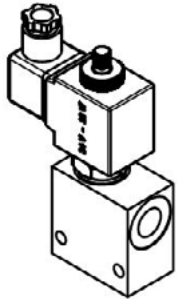

70L

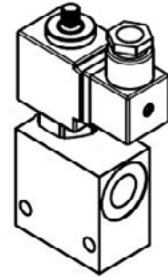

### SPECIFICATIONS

Thread:	3/8
Fluid viscosity:	ISO 3448
Filtration:	ISO 4406
Fluid temperature:	-20°C + 90°C
Ambient temperature:	-20°C + 50°C
Max. operating pressure:	280 Bar
Standard seals:	NBR
Material:	Aluminium
Type override:	push knob

### DIMENSIONS (mm)

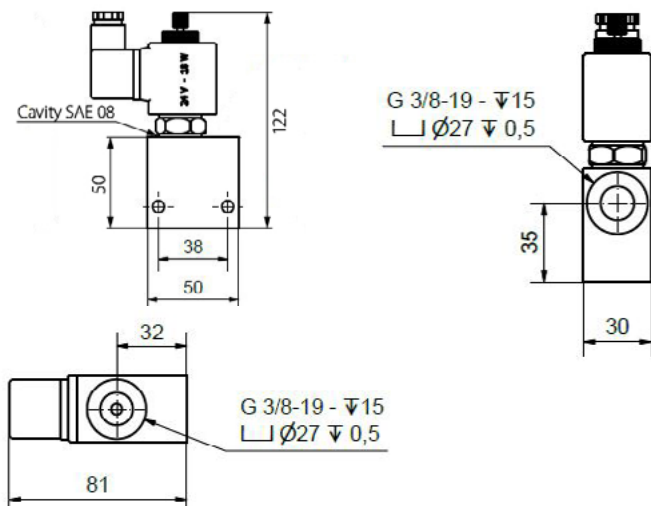

### SPECIFICATIONS

Thread:	1/2
Fluid viscosity:	ISO 3448
Filtration:	ISO 4406
Fluid temperature:	-20°C + 90°C
Ambient temperature:	-20°C + 50°C
Max. operating pressure:	280 Bar
Standard seals:	NBR
Material:	Aluminium
Type override:	push knob

### DIMENSIONS (mm)

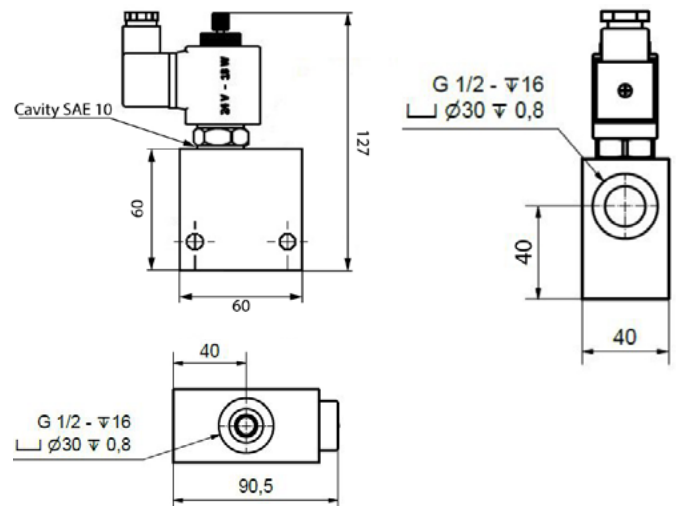

Standard code	Volt
SV-2/2-NO-40-38-12V	12 dc
SV-2/2-NO-40-38-24V	24 dc
SV-2/2-NO-40-38-220V	220 rac

Standard code	Volt
SV-2/2-NO-70-12-12V	12 dc
SV-2/2-NO-70-12-24V	24 dc
SV-2/2-NO-70-12-220V	220 rac

## 2/2 NORMALLY CLOSED

40L

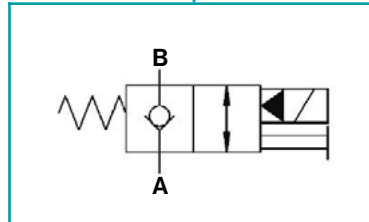
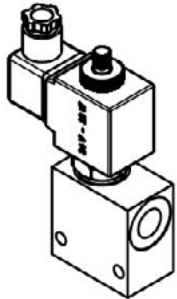

70L

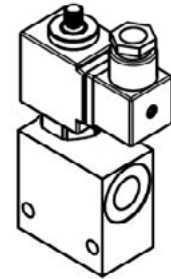

### SPECIFICATIONS

Thread:	3/8
Fluid viscosity:	ISO 3448
Filtration:	ISO 4406
Fluid temperature:	-20°C + 90°C
Ambient temperature:	-20°C + 50°C
Max. operating pressure:	280 Bar
Standard seals:	NBR
Material:	Aluminium
Type override:	screw

### DIMENSIONS (mm)

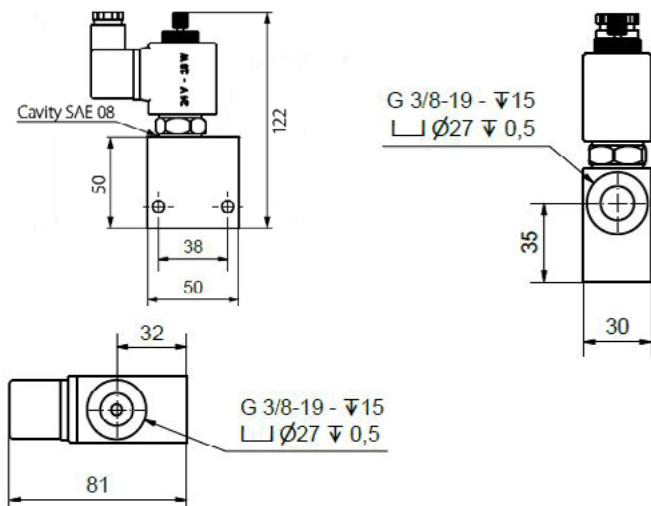

### SPECIFICATIONS

Thread:	1/2
Fluid viscosity:	ISO 3448
Filtration:	ISO 4406
Fluid temperature:	-20°C + 90°C
Ambient temperature:	-20°C + 50°C
Max. operating pressure:	280 Bar
Standard seals:	NBR
Material:	Aluminium
Type override:	push and twist

### DIMENSIONS (mm)

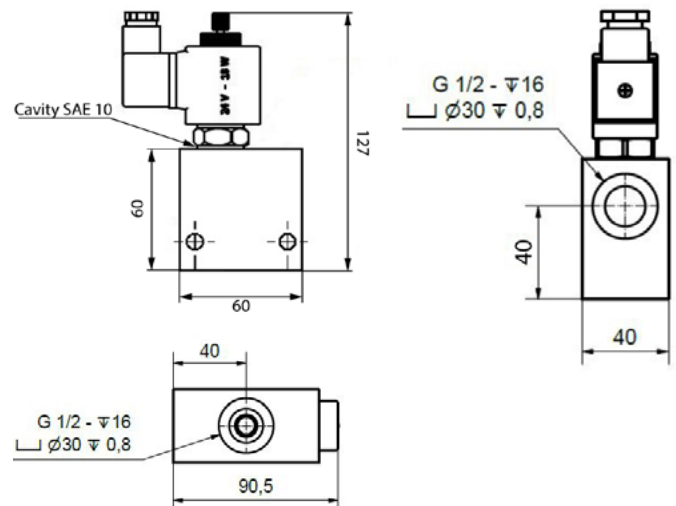

Standard code	Volt
SV-2/2-NC-40-38-12V	12 dc
SV-2/2-NC-40-38-24V	24 dc
SV-2/2-NC-40-38-220V	220 rac

Standard code	Volt
SV-2/2-NC-70-12-12V	12 dc
SV-2/2-NC-70-12-24V	24 dc
SV-2/2-NC-70-12-220V	220 rac

## 2/2 NORMALLY OPEN DOUBLE LOCK VALVE

40L

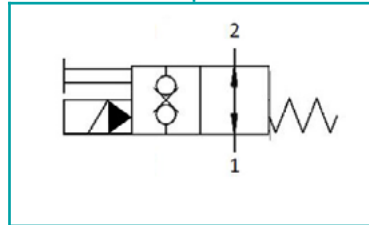
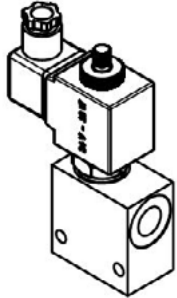

70L

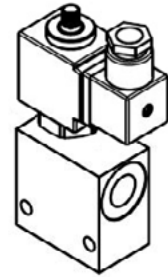

### SPECIFICATIONS

Thread:	3/8
Fluid viscosity:	ISO 3448
Filtration:	ISO 4406
Fluid temperature:	-20°C + 90°C
Ambient temperature:	-20°C + 50°C
Max. operating pressure:	280 Bar
Standard seals:	NBR
Material:	Aluminium
Type override:	screw

### DIMENSIONS (mm)

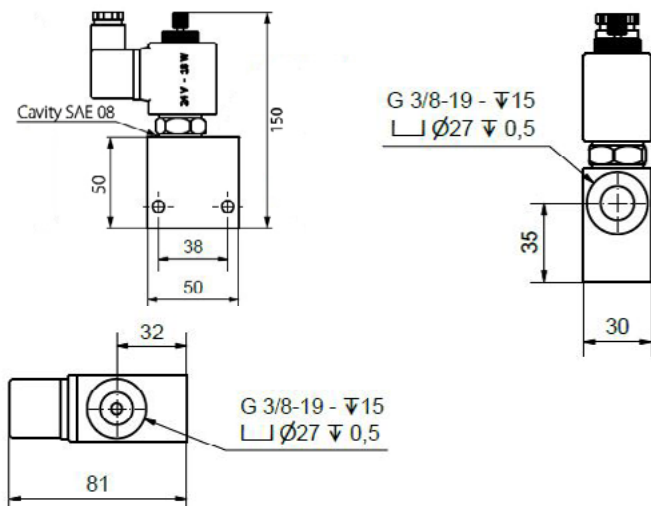

### SPECIFICATIONS

Thread:	1/2
Fluid viscosity:	ISO 3448
Filtration:	ISO 4406
Fluid temperature:	-20°C + 90°C
Ambient temperature:	-20°C + 50°C
Max. operating pressure:	280 Bar
Standard seals:	NBR
Material:	Aluminium
Type override:	push button

### DIMENSIONS (mm)

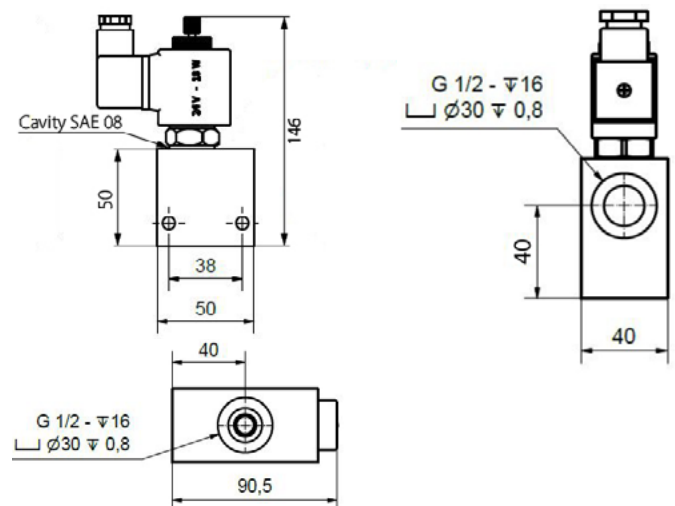

Standar code	Volt
SV-2/2-NO-DC-40-38-12V	12 dc
SV-2/2-NO-DC-40-38-24V	24 dc
SV-2/2-NO-DC-40-38-220V	220 rac

Standar code	Volt
SV-2/2-NO-DC-70-12-12V	12 dc
SV-2/2-NO-DC-70-12-24V	24 dc
SV-2/2-NO-DC-70-12-220V	220 rac

## 2/2 NORMALLY CLOSED DOUBLE LOCK VALVE

### 15L /30L

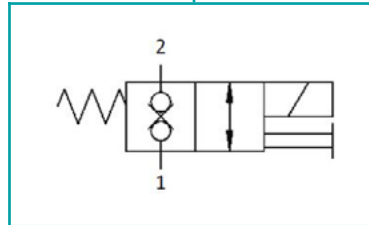
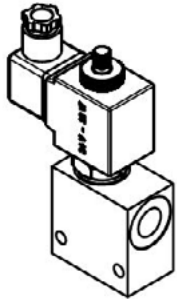

### 70L

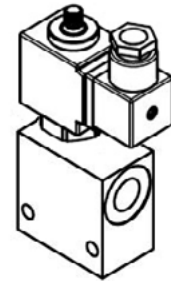

### SPECIFICATIONS

Thread:	3/8
Fluid viscosity:	ISO 3448
Filtration:	ISO 4406
Fluid temperature:	-20°C + 90°C
Ambient temperature:	-20°C + 50°C
Max. operating pressure:	280 Bar
Standard seals:	NBR
Material:	Aluminium
Type override:	push knob

### DIMENSIONS (mm)

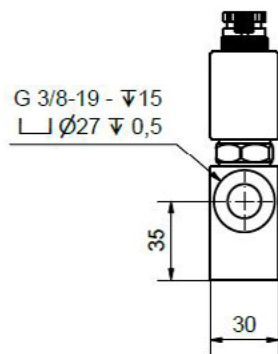
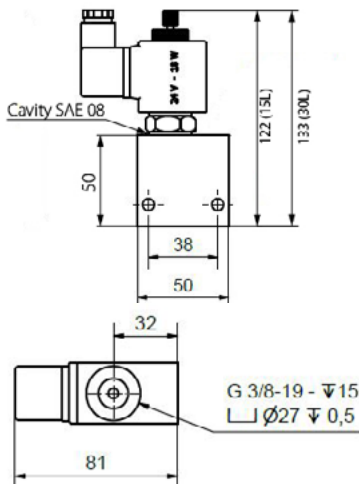

### SPECIFICATIONS

Thread:	1/2
Fluid viscosity:	ISO 3448
Filtration:	ISO 4406
Fluid temperature:	-20°C + 90°C
Ambient temperature:	-20°C + 50°C
Max. operating pressure:	280 Bar
Standard seals:	NBR
Material:	Aluminium
Type override:	screw

### DIMENSIONS (mm)

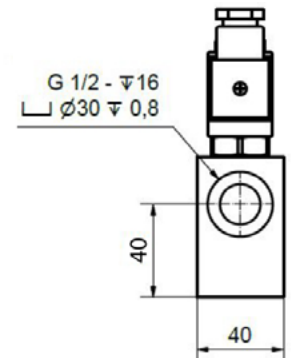
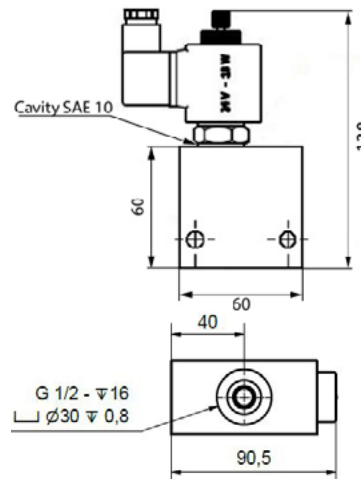

Standard code	Volt
SV-2/2-NC-DC-15-38-12V	12 dc
SV-2/2-NC-DC-15-38-24V	24 dc
SV-2/2-NC-DC-15-38-220V	220 rac
SV-2/2-NC-DC-30-38-12V	12 dc
SV-2/2-NC-DC-30-38-24V	24 dc
SV-2/2-NC-DC-30-38-220V	220 rac

Standard code	Volt
SV-2/2-NC-70-12-12V	12 dc
SV-2/2-NC-70-12-24V	24 dc
SV-2/2-NC-70-12-220V	220 rac

## COIL

### 18W

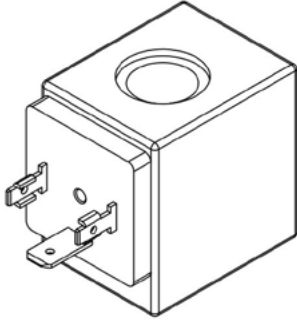

#### SPECIFICATIONS

Power	18W
Coil insulation class	F
ED	100%
Supply power tolerance	±10%DC; +10% -5%AC
Ambient temperature	-30°C +50°C
IP Coil	54

#### DIMENSIONS (mm)

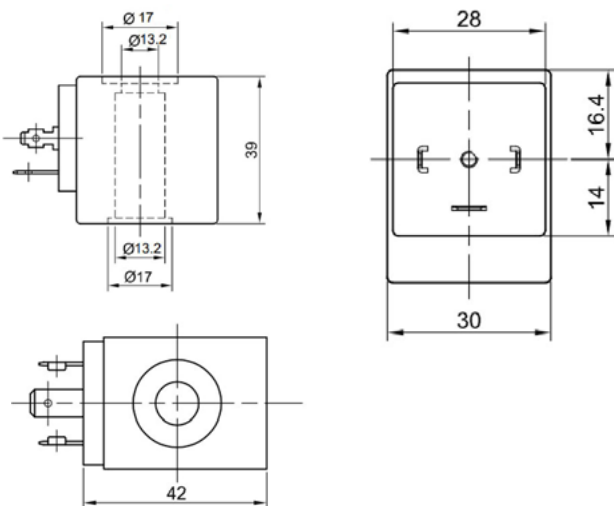

Standard code	Ø	Volt	W
VNKPP050801	13	12 dc	18
VNKPP050802	13	24 dc	18
VNKPP050803	13	110 rac	18
VNKPP050804	13	220 rac	18

### 22W

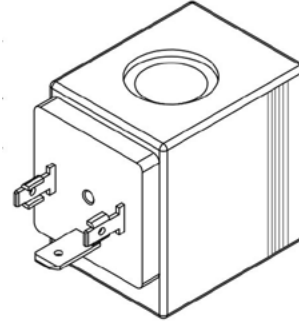

#### SPECIFICATIONS

Power	22W
Coil insulation class	H
ED	100%
Supply power tolerance	±10%DC; +10% -5%AC
Ambient temperature	-30°C +50°C
IP Coil	54

#### DIMENSIONS (mm)

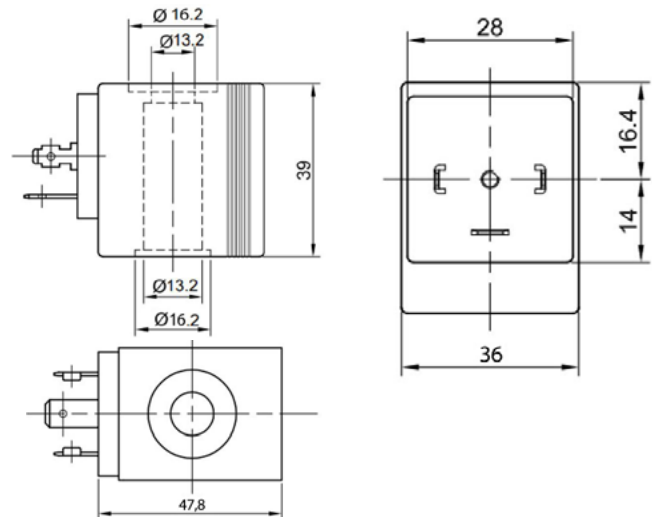

Standard code	Ø	Volt	W
VNKPP050901	13	12 dc	22
VNKPP050902	13	24 dc	22
VNKPP050903	13	26 dc	22
VNKPP050904	13	110 rac	22
VNKPP050905	13	220 rac	22

## OVERRIDE TYPES

### SCREW

---

**Description:**

To operate this override, manually unscrew/screw-in the knob to full stroke position. Once in this mode, the override is self-detended. To return to the de-energized mode, screw-in/unscrew the override knob until positive stop occurs. External dimensions change depending on the valve type.



### PUSH AND TWIST

---

**Description:**

To operate this override, manually push and twist the knurled knob counterclockwise/clockwise. Once in this mode, the override is selfdetended. To return to the de-energized mode, push and twist the override knob clockwise/counterclockwise. External dimensions change depending on the valve type.



### PUSH KNOB

---

**Description:**

In order to operate this override, press the pin with a finger and maintain constant pressure. Once released,the valve will get back to the de-energized mode. External valve dimensions increase.

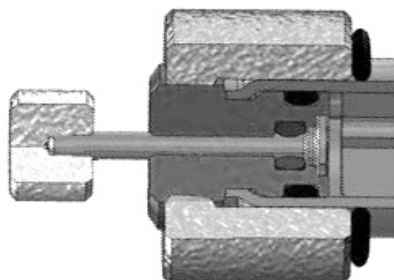

## EXTERNAL PILOT OPERATED SINGLE CHECK VALVES

### SPECIFICATIONS

Fluid viscosity:	ISO 3448
Filtration:	ISO 4406
Fluid temperature:	-20°C + 90°C
Ambient temperature:	-20°C + 50°C
Standard seals:	NBR
External surfaces:	Zinc plated steel

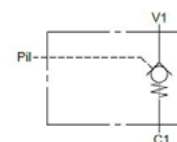

### DIMENSIONS (mm)

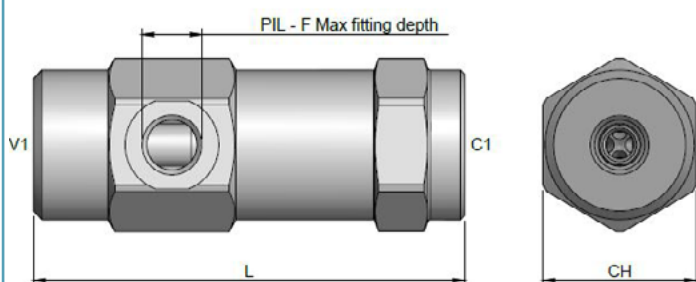

### PERFORMANCE

Oil viscosity 24 mm<sup>3</sup>/s (3,5 °E) - Temperature 50°C

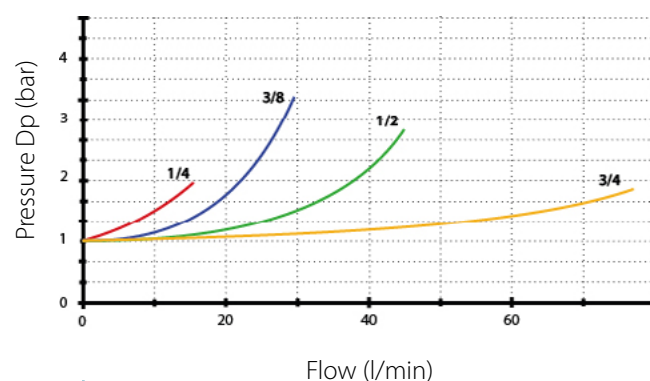

X = 1 bar Std  
Y = 3 bar  
Z = 8 bar

Standard code	Thread	L	F	CH	Weight (kg)	Q max (l/min)	Max Pressure	Pilot ratio
K-SPCELV-14	1/4	103	12	35	0.7	20	350	8.5 : 1
K-SPCELV-38	3/8	109	12	40	0.9	30	300	6 : 1
K-SPCELV-12	1/2	122	12	42	1.1	45	300	5.5 : 1
K-SPCELV-34	3/4	131	14	55	2	80	250	4 : 1

## SINGLE PILOT CHECK VALVE 90°

### SPECIFICATIONS

Fluid viscosity:	ISO 3448
Filtration:	ISO 4406
Fluid temperature:	-20°C + 90°C
Ambient temperature:	-20°C + 50°C
Max. operating pressure:	350 Bar
Standard seals:	NBR
External surfaces:	Zinc plated steel

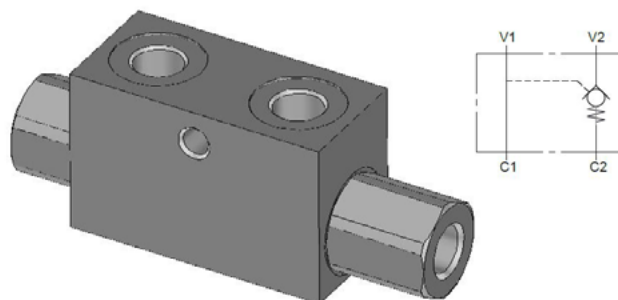

### DIMENSIONS (mm)

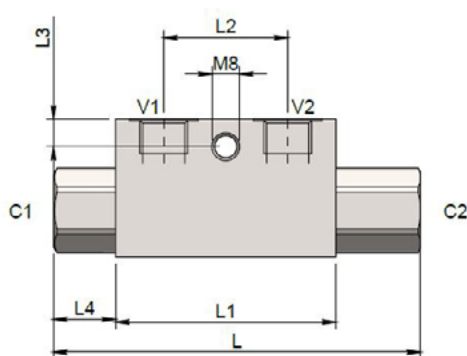
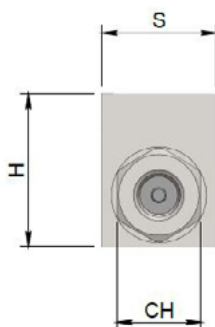

### PERFORMANCE

Oil viscosity 24 mm<sup>3</sup>/s (3,5 °E) - Temperature 50°C

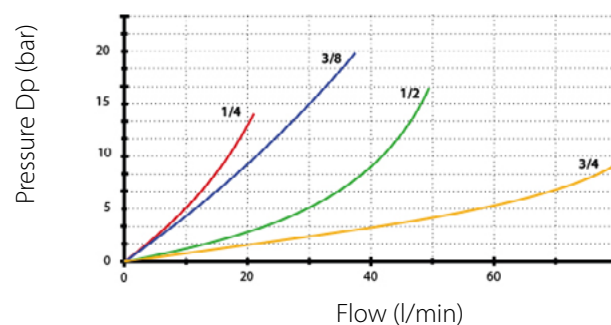

Y = Std on table  
X = 1 bar

Standard code	Thread	L	L1	L2	L3	L4	H	S	CH	Weight (kg)	Q max (l/min)	Cracking P	Pilot ratio
K-SPCLV-14	1/4	106.5	64	36	8	18	40	30	22	0.61	20	4	5.5 : 1
K-SPCLV-38	3/8	120	68	38	8	22	40	30	22	0.70	35	3	5.5 : 1
K-SPCLV-12	1/2	133	90	46	12.5	17	45	35	27	1.00	50	6	5 : 1
K-SPCLV-34	3/4	182	100	46	12	36	60	40	36	1.70	100	2	4 : 1

## 90° DOUBLE PILOT OPERATED CHECK VALVES

### SPECIFICATIONS

Fluid viscosity:	ISO 3448
Filtration:	ISO 4406
Fluid temperature:	-20°C + 90°C
Ambient temperature:	-20°C + 50°C
Max. operating pressure:	350 Bar
Standard seals:	NBR
Manifold material:	Zinc plated steel

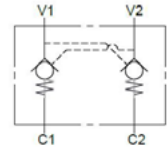
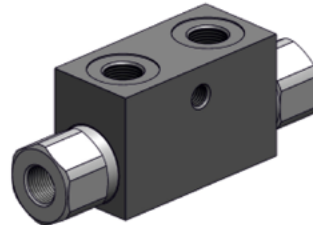

### DIMENSIONS (mm)

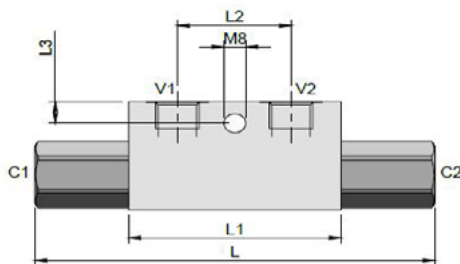
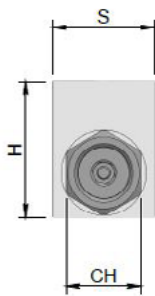

### PERFORMANCE

Oil viscosity 24 mm<sup>2</sup>/s (3,5 °E) - Temperature 50°C

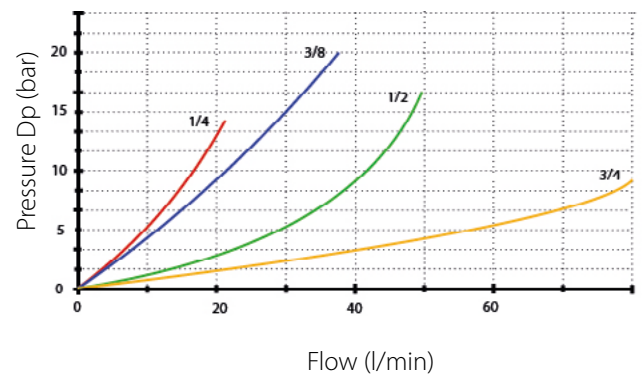

Standard code	Thread	L	L1	L2	L3	H	S	CH	Weigh (kg)	Q max (l/min)	Carcking P	Pilot ratio
K-DPCLV-14	1/4	113	64	36	8	40	30	22	0.65	20	4	5.5 : 1
K-DPCLV-38	3/8	128	68	38	8	40	30	22	0.75	35	3	5.5 : 1
K-DPCLV-12	1/2	142	90	45	12.5	45	35	27	1.05	50	6	5.1
K-DPCLV-34	3/4	192	100	46	12	60	40	36	1.95	100	2	4.1

## 90° DOUBLE PILOT OPERATED CHECK VALVES DIN 2353

### SPECIFICATIONS

Fluid viscosity:	10 - 550mm <sup>2</sup> /s
Filtration:	ISO 16/13
Fluid temperature:	-20°C + 90°C
Ambient temperature:	-20°C + 50°C
Max. operating pressure:	350 Bar
Standard seals:	NBR
Manifold material:	Zinc plated steel

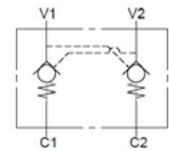
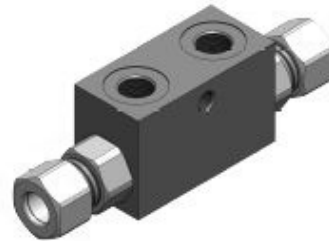

### DIMENSIONS (mm)

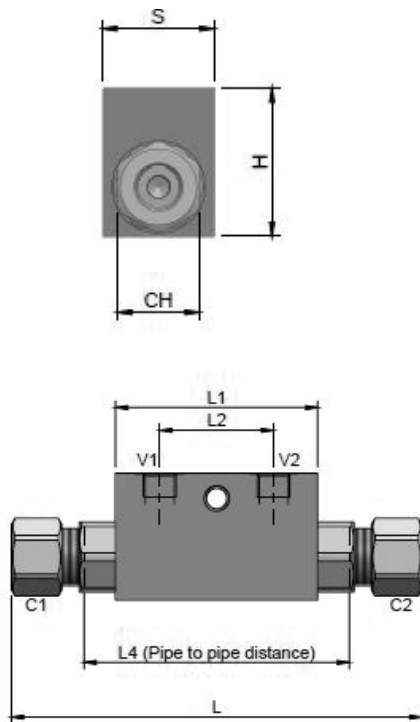

### PERFORMANCE

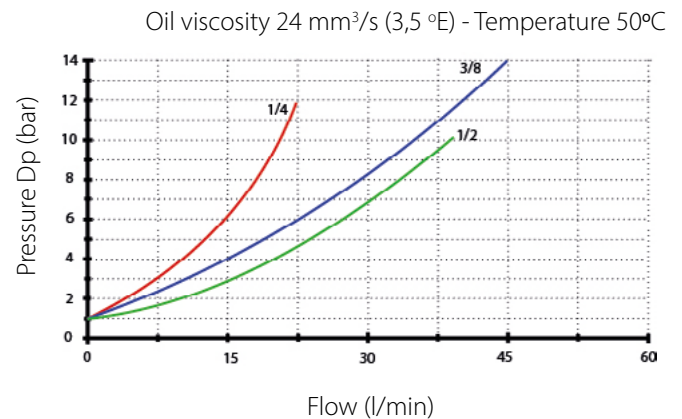

Standard code	Thread	Ø	L	L1	L2	L3	L4	H	S	CH	Weigh (kg)	Q max (l/min)	Pilot ratio
K-DPCLV-14-12L	1/4	12L	130	64	36	160	84	40	30	22	0.69	20	5.5 : 1
K-DPCLV-38-12L	3/8	12L	130	64	36	166	84	40	30	22	0.67	30	5.5 : 1
K-DPVLV-12-15L	1/2	15L	164	90	45	196	106	45	35	30	1.10	50	5 : 1

## DUAL FLANGEABLE PILOT OPERATED CHECK VALVES

### SPECIFICATIONS

Fluid viscosity:	ISO 3448
Filtration:	ISO 4406
Fluid temperature:	-20°C + 90°C
Ambient temperature:	-20°C + 50°C
Max. operating pressure:	300 Bar
Q Max (l/min)	20
Pilot ratio:	4.9 : 1
Standard seals:	NBR
External surfaces:	Zinc plated steel

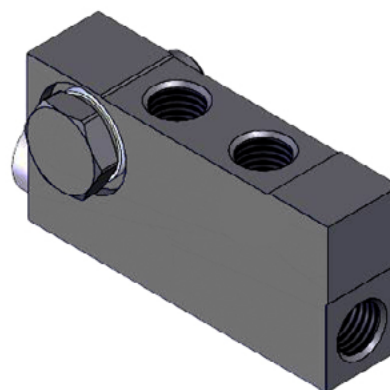

### DIMENSIONS (mm)

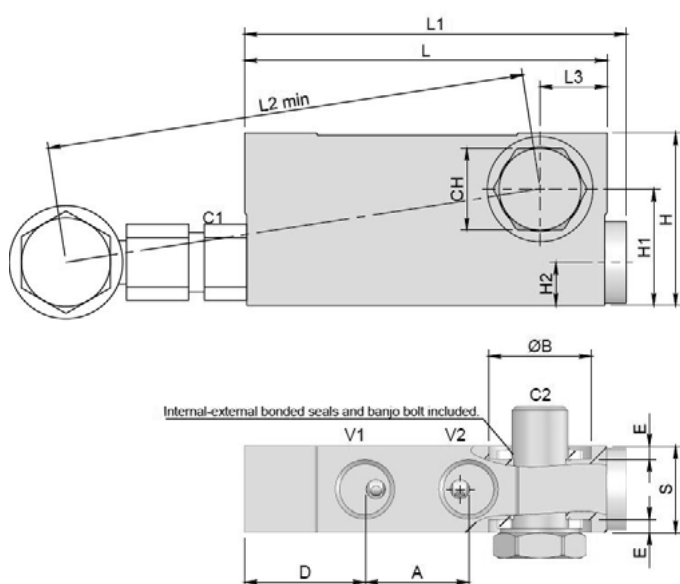

### PERFORMANCE

Oil viscosity 24 mm<sup>3</sup>/s (3,5 °E) - Temperature 50°C

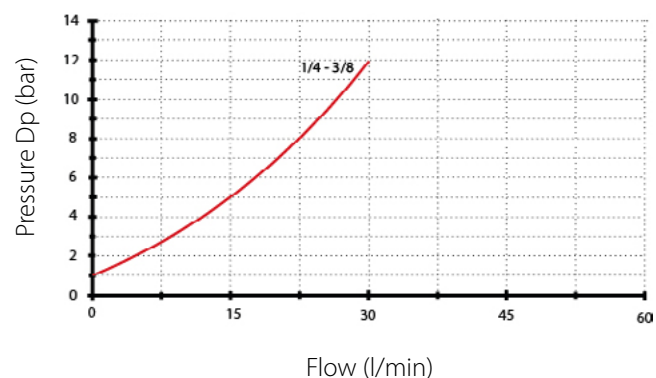

Standard code	Thread	L	L1	L2	L3	A	ØB	D	E	H	H1	H2	S	CH	kg	Cr. Press
K-DPCLV-F-14	1/4	84	88.5	123	15.5	24	243	28	3	40	27	10	80	19	0.48	1
K-DPCLV-F-38	3/8	86	90.5	127	14	29	27	23	4	45	30.5	12.5	25	22	0.68	1

## CHECK VALVES ACCESORIES

### BANJO PIPE

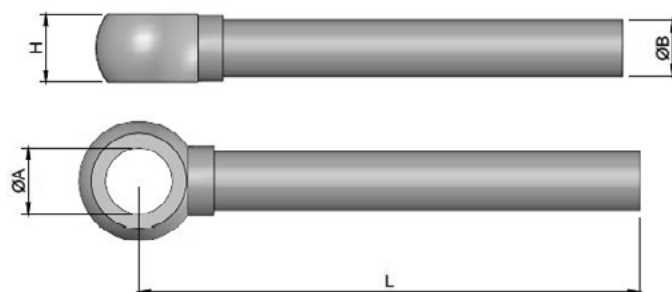

Standard code	Thread	Ø	L	H	ØA	ØB
VNKL050108.7	1/4	12L	40	13.3	14.5	12
VNKL050109	1/4	12L	100	13.3	14.5	12
VNKL050110	1/4	12L	300	13.3	14.5	12
VNKL050111	1/4	12L	500	13.3	14.5	12
VNKL050111.9	3/8	12L	40	17	17	12
VNKL050112	3/8	12L	100	17	17	12
VNKL050112.5	3/8	12L	200	17	17	12
VNKL050113	3/8	12L	300	17	17	12
VNKL050114	3/8	12L	500	17	17	12
VNKL050115	1/2	15L	100	21.2	22	15
VNKL050116	1/2	15L	300	21.5	22	15

### BANJO AND NUT DIN 2353

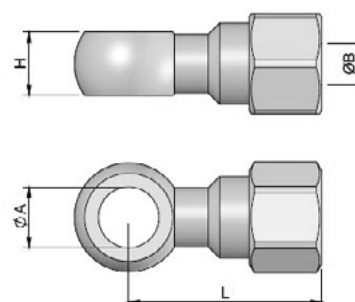
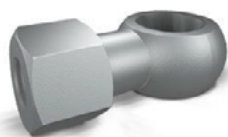

Standard code	Thread	Ø	L	H	ØA	ØB
VNKL050117	1/4	12L	43.5	14	13.3	12
VNKL050118	3/8	12L	38.5	17	17	12
VNKL050119	1/2	15L	44.5	22	21.2	15

## K-BV HOSE BURST VALVES

### SPECIFICATIONS

Fluid viscosity:	ISO 6743/4
Filtration:	ISO 4406
Fluid temperature:	-20°C + 80°C
Ambient temperature:	-20°C + 50°C
Max pressure	350 bar

It's necessary a filter use to protect the valve.  
Max leakage in the version without hole: 0,25 cm<sup>3</sup>/min.



### DIMENSIONS (mm)

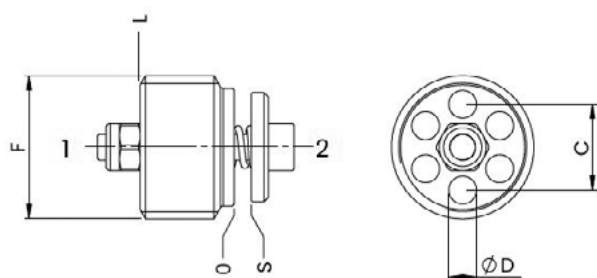

### PERFORMANCE

Oil viscosity 24 mm<sup>3</sup>/s (3,5 °E) - Temperature 50°C

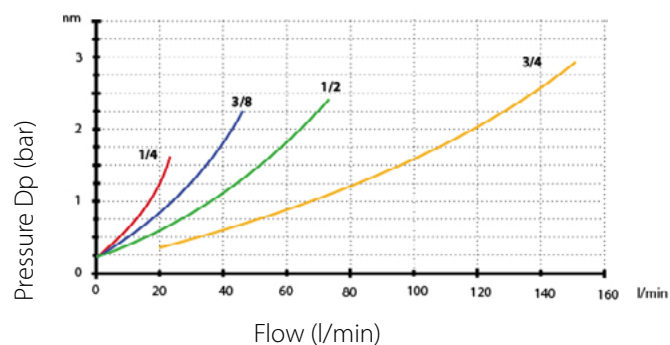

Standard code	Thread	C	D	L	Valve Tightening Torque	Nut Tightening torque for adjustment	Weight (kg)	Q max (l/min)
K-BV-14	1/4	8	2.5	8.2	4	1	0.008	25
K-BV-38	3/8	10	3.25	11	6	1	0.014	50
K-BV-12	1/2	11.5	4	13	10	2	0.025	80
K-BV-34	3/4	14.5	5.2	18	15	2	0.05	150

### HOUSING

#### VALVE BODY FEMALE-MALE

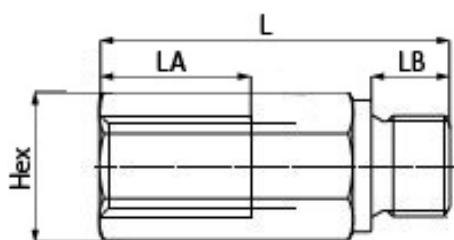

#### VALVE BODY FEMALE-FEMALE

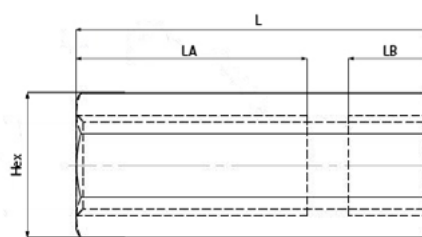

Standard code	Thread	L	LB	LA	Hex	kg
K-BV-14 MF	1/4	50	12	20.5	19	0.08
K-BV-38 MF	3/8	58	13	22.5	24	0.14
K-BV-12 MF	1/2	62	14	22.5	27	0.18
K-BV-34 MF	3/4	75	16	24.5	32	0.30

Standard code	Thread	L	LB	LA	Hex	kg
K-BV-14 FF	1/4	50	14	19	19	0.09
K-BV-38 FF	3/8	58	17	23	24	0.16
K-BV-12 FF	1/2	62	18	22.5	27	0.20
K-BV-34 FF	3/4	75	21	23.5	32	0.30

## UNIDIRECTIONAL PANEL MOUNTING FLOW CONTROL VALVES

### SPECIFICATIONS

Fluid viscosity:	ISO 3448
Filtration:	ISO 4406
Fluid temperature:	-20°C + 90°C
Ambient temperature:	-20°C + 50°C
Manifold material:	Zinc plated steel

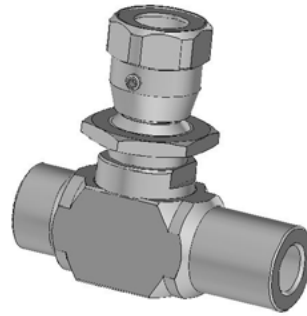

### DIMENSIONS (mm)

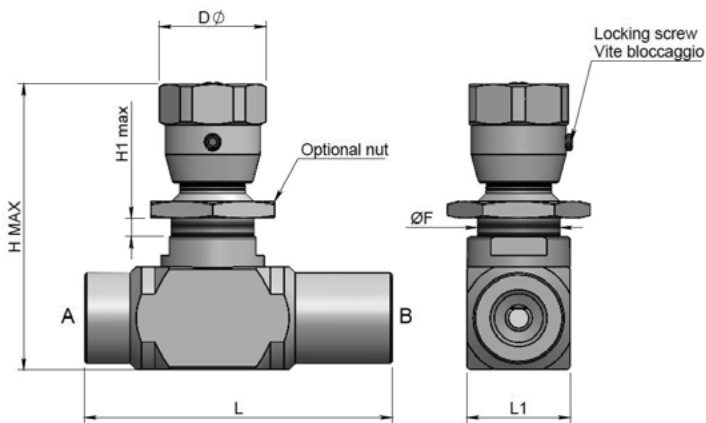

### PERFORMANCE

Oil viscosity 24 mm<sup>3</sup>/s (3,5 °E) - Temperature 50°C

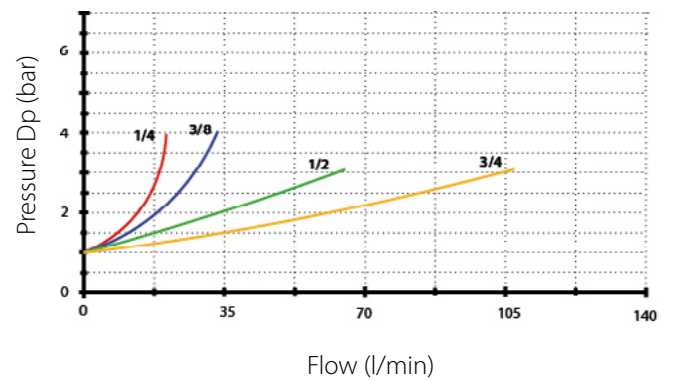

Standard code	Thread	ØF	L	L1	ØD	H max	H1 max	kg	Max Pressure	Q max (l/min)
DV-SC-14	1/4	M20x1.5	73	25	26	75	4.5	0.4	400	15
DV-SC-38	3/8	M20x1.5	83	30	26	83	4.5	0.4	400	30
DV-SC-12	1/2	M20x1.5	94	30	26	90	4.5	0.6	400	50

## BIDIRECTIONAL PANEL MOUNTING FLOW CONTROL VALVES

### SPECIFICATIONS

Fluid viscosity:	ISO 3448
Filtration:	ISO 4406
Fluid temperature:	-20°C + 90°C
Ambient temperature:	-20°C + 50°C
Manifold material:	Zinc plated steel

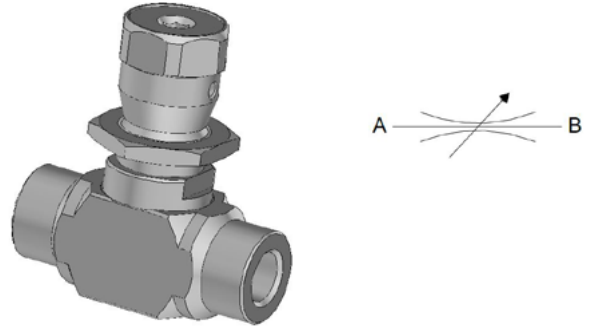

### DIMENSIONS (mm)

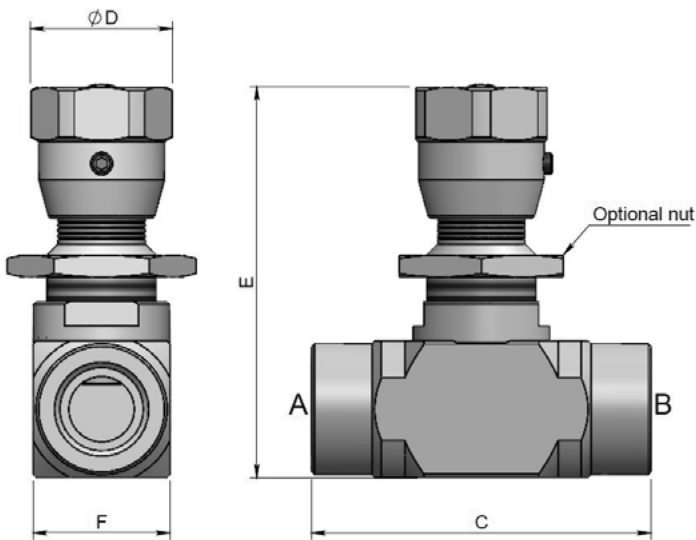

### PERFORMANCE

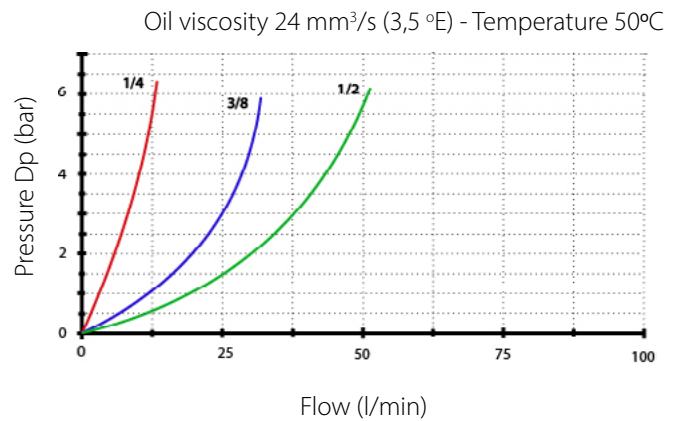

Standard code	Thread	$\varnothing D$	E	F	C	kg	Max Pressure	Q max (l/min)
DRV-SC-14	1/4	26	80	25	62	0.34	350	15
DRV-SC-38	3/8	26	80	25	62	0.33	350	30
DRV-SC-12	1/2	26	88	30	62	0.45	350	50

## 2-WAYS COMPENSATED FLOW CONTROL VALVES

### SPECIFICATIONS

Fluid viscosity:	ISO 3448
Filtration:	ISO 4406
Fluid temperature:	-20°C + 90°C
Ambient temperature:	-20°C + 50°C
External surfaces:	Zinc plated steel

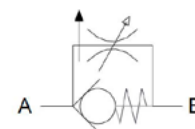
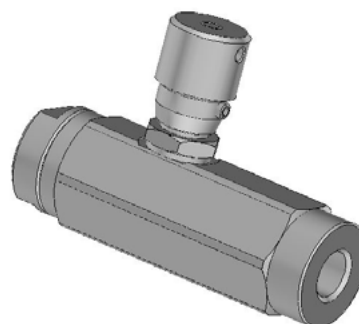

### DIMENSIONS (mm)

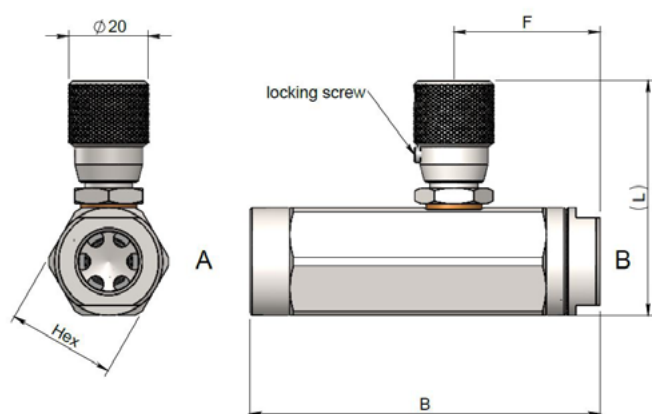

### PERFORMANCE

Oil viscosity 24 mm<sup>2</sup>/s (3,5 °E) - Temperature 50°C

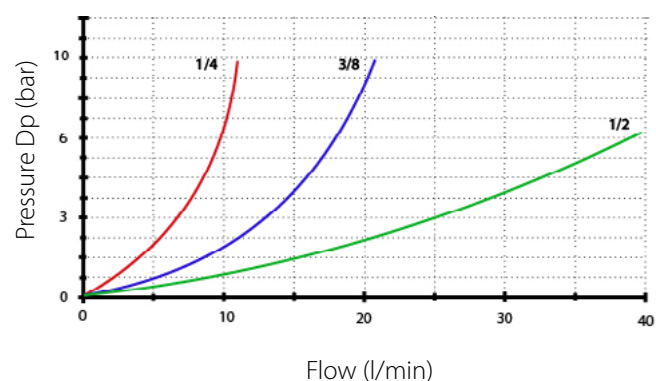

Standard code	Thread	B	F	L	Hex	Weight (kg)	Max. Pressure	Q max (l/min)
K-CFRLV-14	1/4	87.5	36.5	60	27	0.4	250	10
K-CFRLV-38	3/8	87.5	36.5	60	27	0.4	250	20
K-CFRLV-12	1/2	109	46	73	36	0.8	250	45

## BIDIRECTIONAL FLOW CONTROL SCREW BOLT

### SPECIFICATIONS

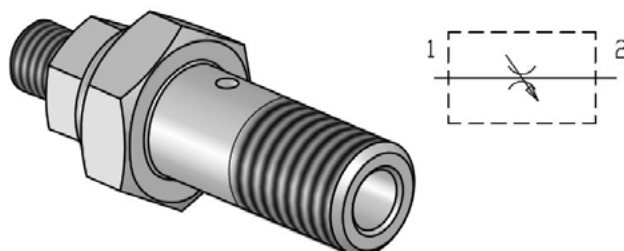

### DIMENSIONS (mm)

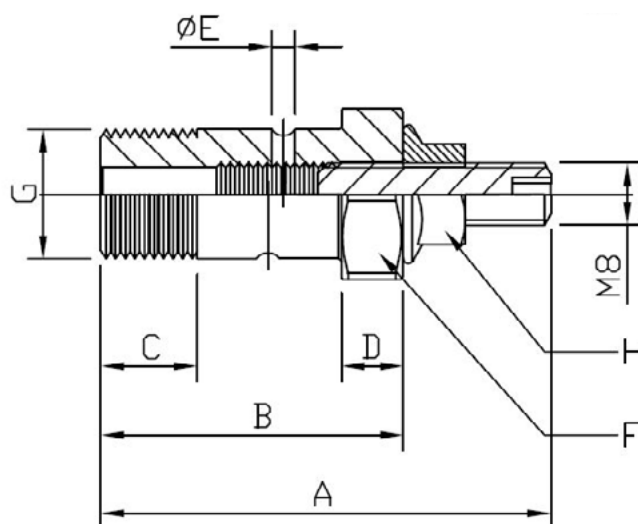

Standard code	Thread	A	B	C	D	E	F	H	M	Weight (kg)
K-CFBLV-14	1/4	53	36	15	7	2.5	19	13	8	0.048
K-CFBLV-38	3/8	58	39	15	8	3	22	13	8	0.076
K-CFBLV-12	1/2	64	46	16	8.5	4	27	13	8	0.120

## BIDIRECTIONAL FLOW CONTROL VALVES

### SPECIFICATIONS

Fluid viscosity:	ISO 3448
Filtration:	ISO 4406
Fluid temperature:	-20°C + 90°C
Ambient temperature:	-20°C + 50°C
Manifold material:	Zinc plated steel

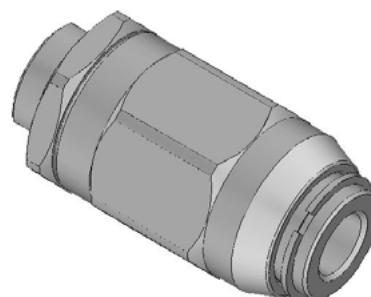

### DIMENSIONS (mm)

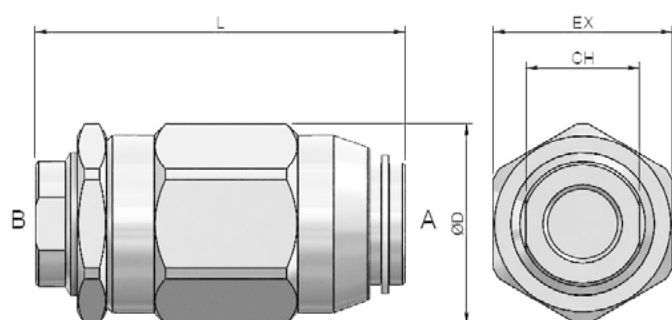

### PERFORMANCE

Oil viscosity 24 mm<sup>3</sup>/s (3,5 °E) - Temperature 50°C

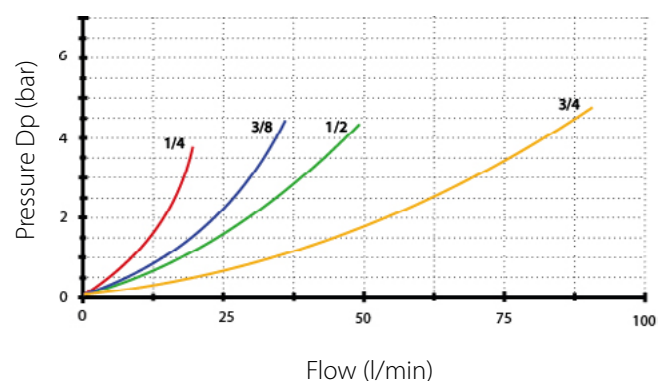

Standard code	Thread	ØD	L	CH	EX	Weight (kg)	Max Pressure	Q max (l/min)
K-FRLV-BHX-14	1/4	33.5	62	19	30	0.24	350	15
K-FRLV-BHX-38	3/8	40.5	73	24	36	0.43	350	35
K-FRLV-BHX-12	1/2	46	83	30	41	0.68	350	45
K-FRLV-BHX-34	3/4	60.5	102	36	55	1.10	300	80

## UNIDIRECTIONAL FLOW CONTROL VALVES

### SPECIFICATIONS

Fluid viscosity:	ISO 3448
Filtration:	ISO 4406
Fluid temperature:	-20°C + 90°C
Ambient temperature:	-20°C + 50°C
Manifold material:	Zinc plated steel



### DIMENSIONS (mm)

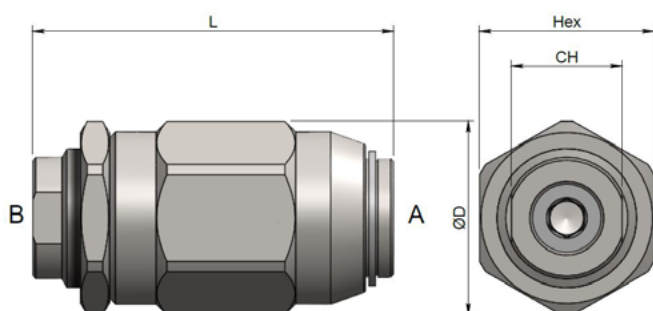

### PERFORMANCE

Oil viscosity 24 mm<sup>2</sup>/s (3,5 °E) - Temperature 50°C

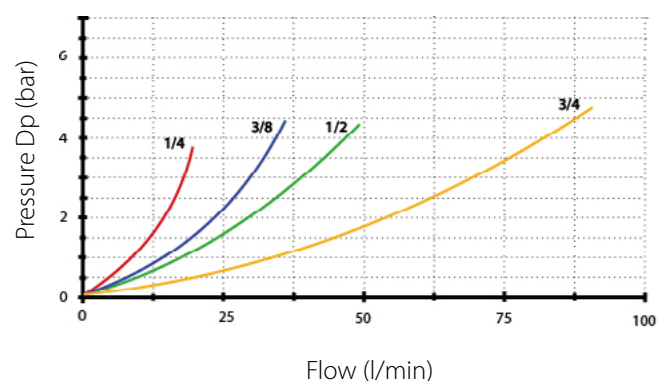

Standard code	Thread	ØD	L	CH	Hex	Weight (kg)	Max Pressure	Q max (l/min)
K-FRLV-UHX-14	1/4	33.5	62	19	30	0.24	350	15
K-FRLV-UHX-38	3/8	35.3	73	24	32	0.43	350	35
K-FRLV-UHX-12	1/2	46	83	30	41	0.68	350	45
K-FRLV-UHX-34	3/4	60.5	102	36	55	1.31	300	80

## BIDIRECTIONAL FLOW CONTROL VALVES

### SPECIFICATIONS

Fluid viscosity:	2.8 - 380 mm/s
Max. pressure (MPa):	31.5
Fluid temperature:	-20°C + 70°C
Ambient temperature:	-20°C + 50°C
Standars seals:	NBR



### DIMENSIONS (mm)

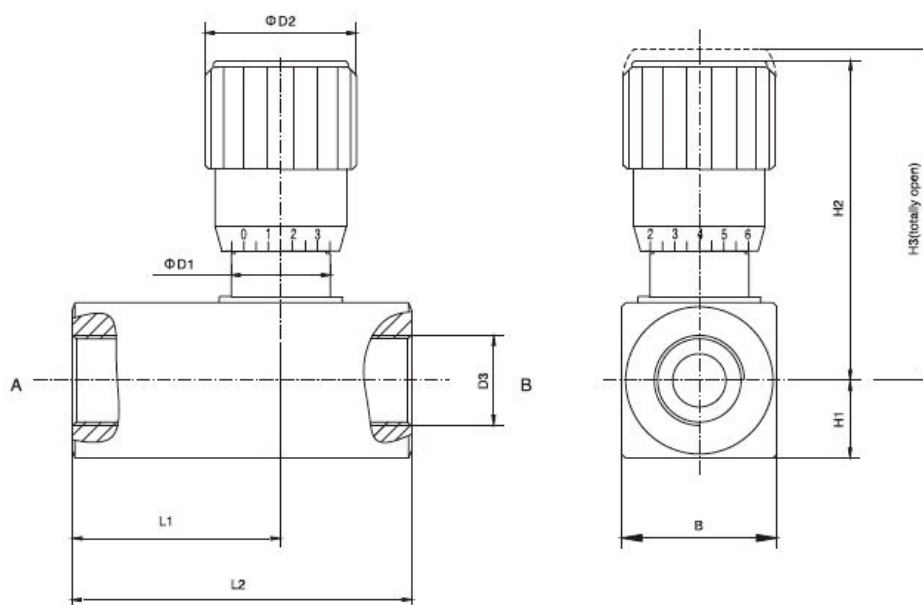

Standard code	B	D1	D2	D3	H1	H2	H3	L1	L2	Q max (l/min)		
DV-8	28	19.3	30	M14X1.5	G 1/4	NPT 1/4	14	61.3	67.9	28	54	60
DV-10	28	19.3	30	M18X1.5	G3/8	NPT3/8	14	61.5	67.5	28	54	75
DV-12	38	24.2	37	M22X1.5	G1/2	NPT1/2	19	78.1	86.5	34	68	140
DV-16	38	24.2	37	M27X2	G3/4	NPT3/4	19	78.3	86.5	39	78	175
DV-20	48	35	48	M33X2	G1"	NPT1"	24	102.3	114.4	45.8	92	200
DV-25	60	50	48	M42X2	G1" 1/4	NPT1" 1/4	30	134.68	148.1	57	114	300

## UNIDIRECTIONAL FLOW CONTROL VALVES

### SPECIFICATIONS

Fluid viscosity:	2.8 - 380 mm/s
Max. pressure (MPa):	31.5
Fluid temperature:	-20°C + 70°C
Ambient temperature:	-20°C + 50°C
Standard seals:	NBR

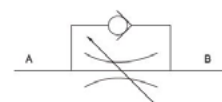

### DIMENSIONS (mm)

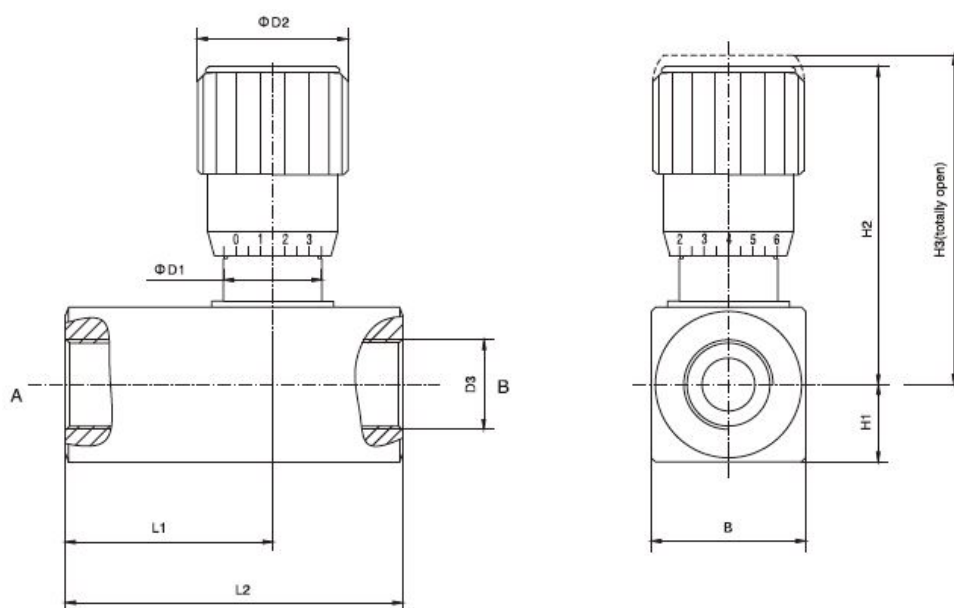

Standard code	B	D1	D2	D3	H1	H2	H3	L1	L2	Q max (l/min)		
DRV-8	28	19.3	30	M14X1.5	G1/4	NPT1/4	14	61.3	67.9	39	64	60
DRV-10	28	19.3	30	M18X1.5	G3/8	NPT3/8	14	61.5	67.5	43	70	75
DRV-12	38	24.2	37	M22X1.5	G1/2	NPT1/2	19	78.1	86.5	52	83	140
DRV-16	38	24.2	37	M27X2	G3/4	NPT3/4	19	78.3	86.5	55.5	89	175
DRV-20	48	35	48	M33X2	G1"	NPT1"	24	102.3	114.4	70.8	117	200
DRV-25	60	50	48	M42X2	G1 1/4"	NPT1 1/4"	30	134.68	148.1	97	154	300
DRV-30	70	70	80	M48X8	G1 1/2"	NPT1 1/2"	35	161.5	181.5	111	172	400

## PROPORTIONAL FLOW REGULATOR 3 WAYS

### SPECIFICATIONS

Max. System Pressure:	241 bar
Leakage:	250cc/min
Hysteresis:	±5%
Viscosity range:	36 to 3000 SU/ 3 to 647 cSt
Filtration:	ISO 18/16/13
Media Operating Temp.range:	-30°C/+100°C
Weight:	0.34kg
Cartridge Torque:	50 Nm
Coil Nut Torque:	3 - 4 Nm

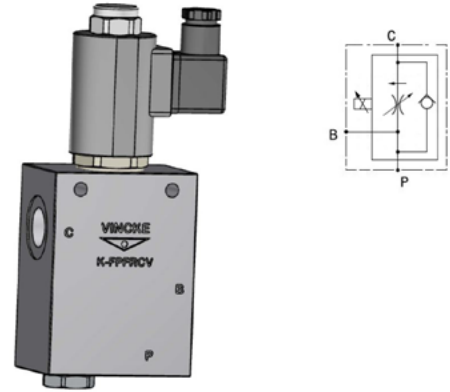

### DIMENSIONS (mm)

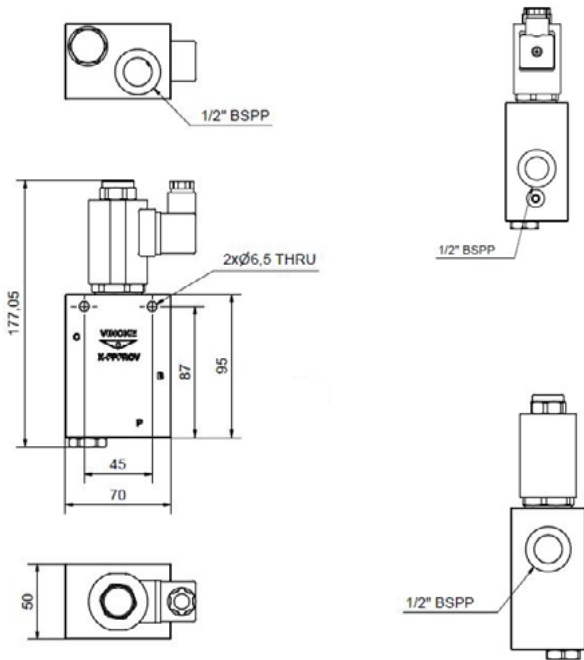

### PERFORMANCE

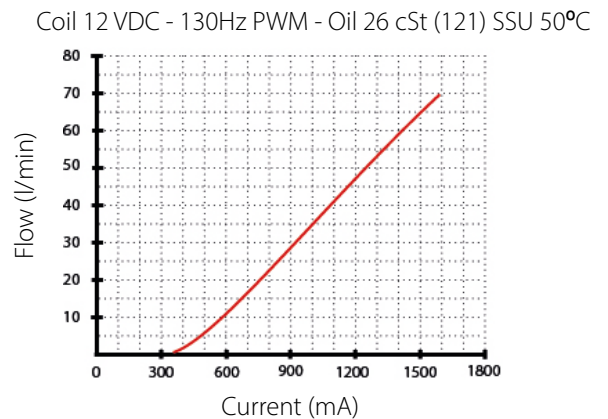

Standard code	Thread	Q max (l/min)	Q (l/min) Reg	Max. Press	Volt.
K-PFRLV-12-12	1/2	110	60	350	12 dc
K-PFRLV-12-24	1/2	110	60	350	24 dc

## LOAD CONTROL SINGLE INTERNAL PILOT

### SPECIFICATIONS

Fluid viscosity:	10 - 550 mm <sup>2</sup> /s
Filtration:	ISO code 16/13
Fluid temperature:	-20°C + 80°C
Ambient temperature:	-20°C + 50°C
Max. operating pressure:	350 Bar
Pilot ratio:	4.25 : 1
Setting at:	5 l/min
Material:	Zinc plated steel

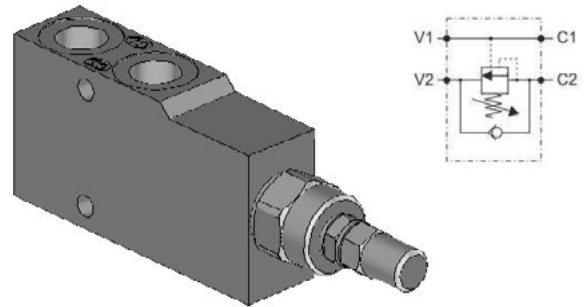

### DIMENSIONS (mm)

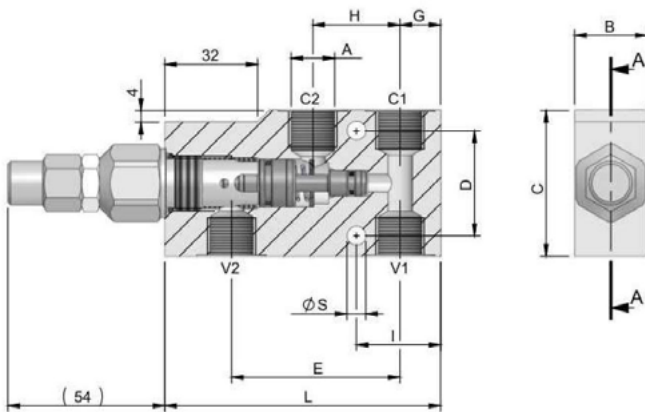

### PERFORMANCE

Oil viscosity 24 mm<sup>3</sup>/s (3,5 °E) - Temperature 50°C

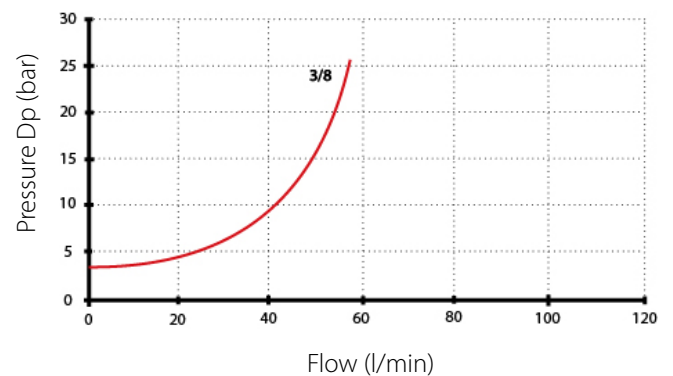

### ADJUSTMENT

**M** Leackproof hex. socket  
Standard screw and cap



Standard code	Thread (A)	B	C	D	E	G	H	I	ØS	Weight (kg)	Q max (l/min)
K-OVCSLV-38	3/8	25	36	58	14	30	95	29	6.5	0.852	40

## LOAD CONTROL SINGLE INTERNAL PILOT

### SPECIFICATIONS

Fluid viscosity:	ISO 3448
Filtration:	ISO 4406
Fluid temperature:	-20°C + 90°C
Ambient temperature:	-20°C + 50°C
Max. operating pressure:	350 Bar
Pilot ratio:	4.25 : 1
Standard seals:	NBR

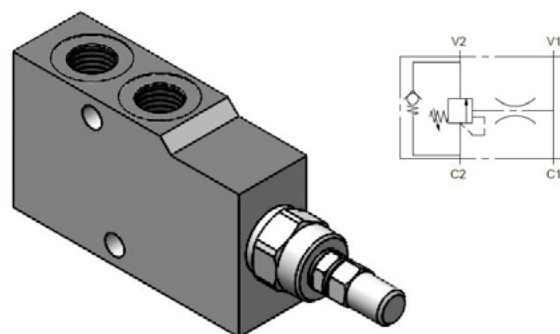

### DIMENSIONS (mm)

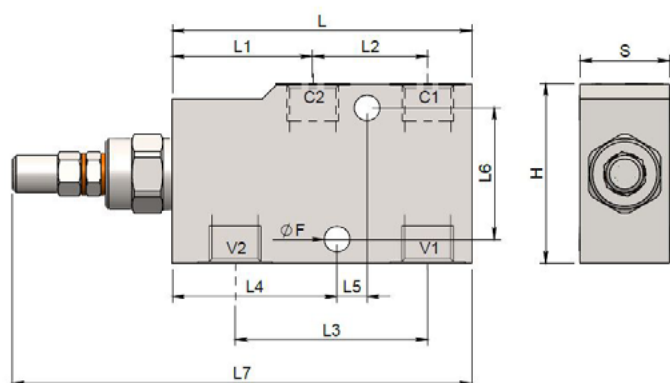

### PERFORMANCE

Oil viscosity 24 mm<sup>2</sup>/s (3,5 °E) - Temperature 50°C

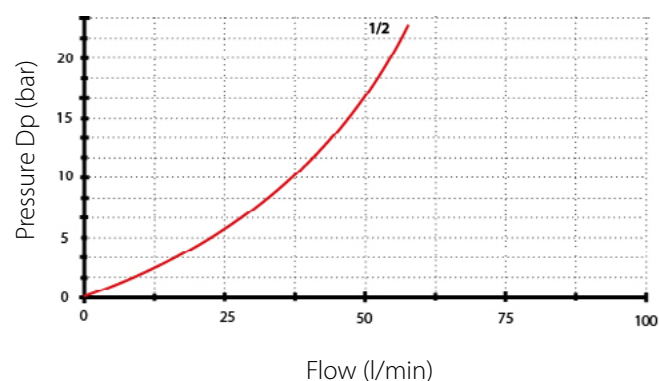

Standard code	Thread	L	L1	L2	L3	L4	L5	L6	L7	H	S	ØF	Weight (kg)	Q max (l/min)
K-OVCDLV-12	1/2	100	50	36	65	57.5	10	44	153.5	60	30	8.5	1.20	60

## LOAD CONTROL DOUBLE INTERNAL PILOT

### SPECIFICATIONS

Fluid viscosity:	10-550mm <sup>2</sup> /s
Filtration:	ISO 16/13
Fluid temperature:	-20°C + 80°C
Ambient temperature:	-20°C + 50°C
Max. operating pressure:	350 Bar
Setting at:	5 l/min
Pilot ratio:	4.25 : 1
Range:	60-350
Std Range:	280
Material:	Zinc plated steel

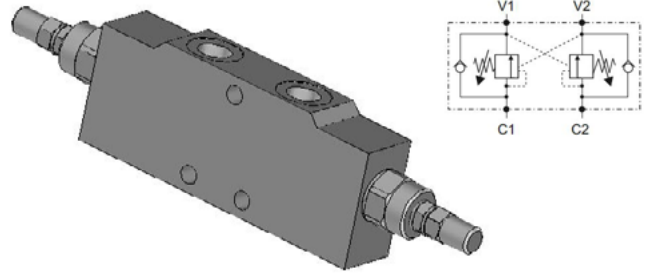

### DIMENSIONS (mm)

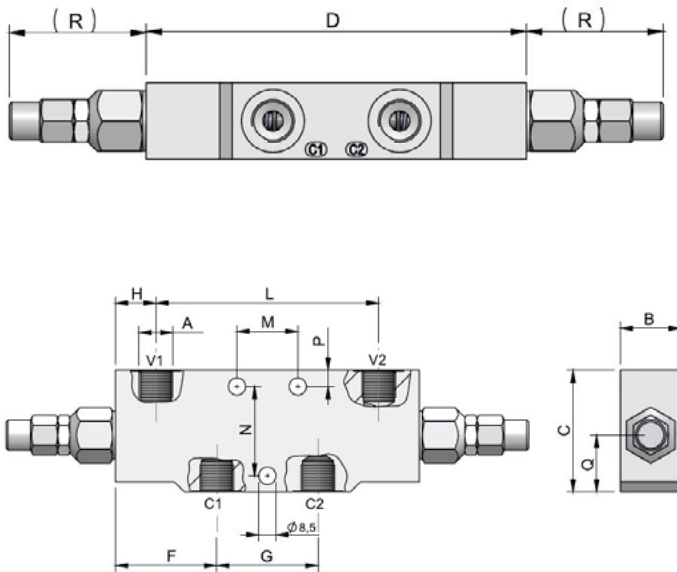

### PERFORMANCE

Oil viscosity 24 mm<sup>2</sup>/s (3,5 °E) - Temperature 50°C

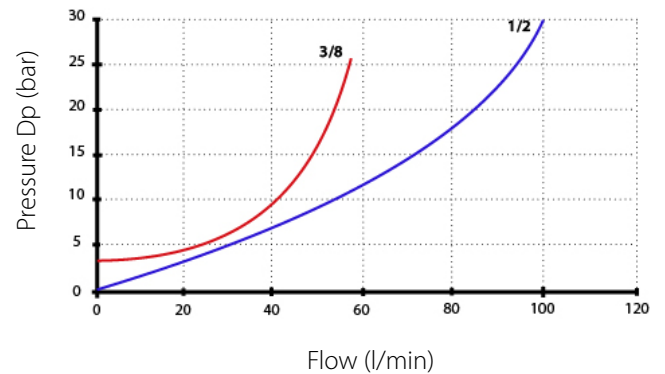

### ADJUSTMENT

M  
Standard      Leakproof hex. socket  
screw and cap



Standard code	Thread	B	C	D	F	G	H	L	M	N	P	Q	R	kg	l/min
K-OVCDLV-38	3/8	30	60	150	45	50	20	110	30	44	8	28	54	2.1	40
K-OVCDLV-12	1/2	30	60	150	45	50	20	110	30	44	8	28	54	2	60

## SEQUENCE VALVES

### SPECIFICATIONS

Fluid viscosity:	10-550 mm <sup>2</sup> /s
Filtration:	ISO 16/13
Fluid temperature:	-20°C + 80°C
Ambient temperature:	-20°C + 50°C
Max. operating pressure:	350 Bar
Setting at:	5 l/min
Material:	Zinc plated steel

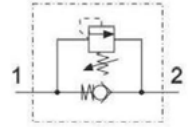
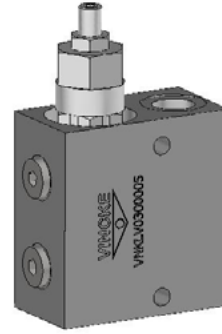

### DIMENSIONS (mm)

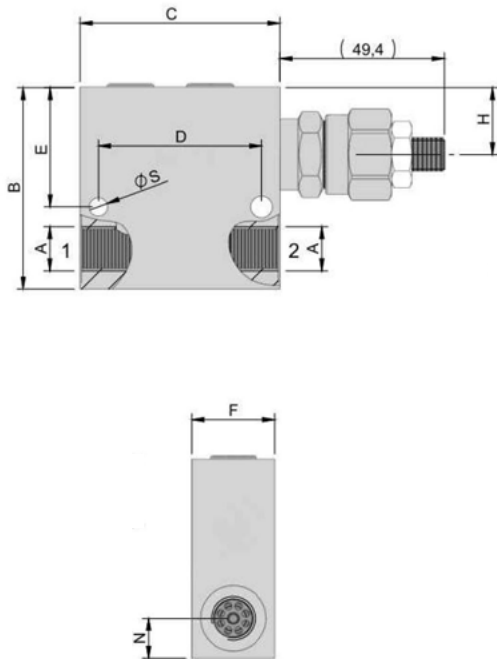

### PERFORMANCE

Oil viscosity 24 mm<sup>3</sup>/s (3,5 °E) - Temperature 50°C

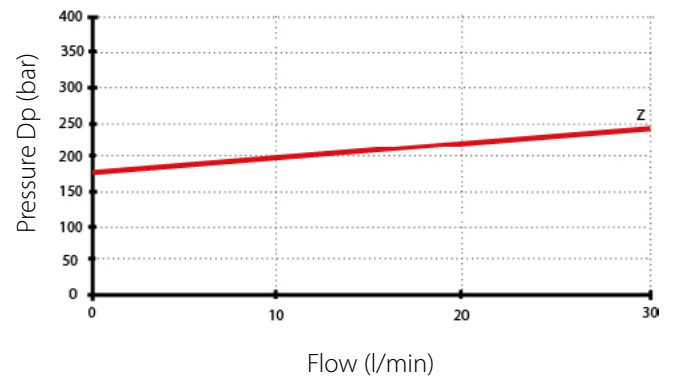

	Range	Standard Calibration	Pressure increase (bar/turn)
Z	50-210	200	65

### ADJUSTMENT

M Leackproof hex. socket screw



Standard code	Thread	B	C	D	E	F	H	N	ØS	Weight (kg)	Q max (l/min)
K-SQLV-38	3/8	60	70	58	32.5	30	17	13	6.5	0.7	20
K-SQLV-12	1/2	70	70	58	35	30	17	17	6.5	0.9	40

## SHUTTLE VALVES

### SPECIFICATIONS

Fluid viscosity:	ISO 3448
Filtration:	ISO 4406
Fluid temperature:	-20°C + 90°C
Ambient temperature:	-20°C + 50°C
Max. operating pressure:	350 Bar
External surfaces:	Zinc plated steel

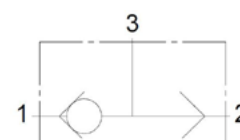
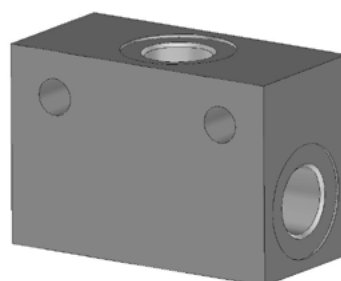

### DIMENSIONS (mm)

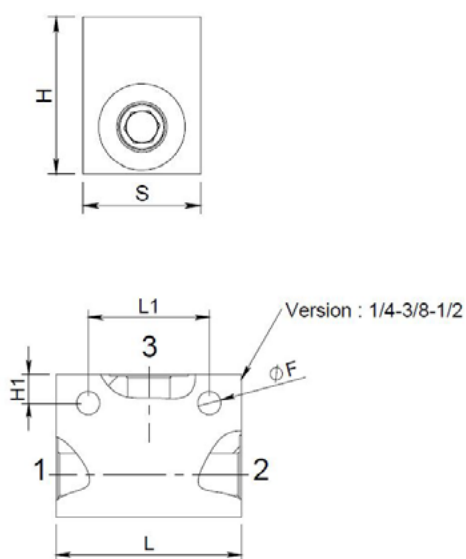

### PERFORMANCE

Oil viscosity 24 mm<sup>2</sup>/s (3,5 °E) - Temperature 50°C

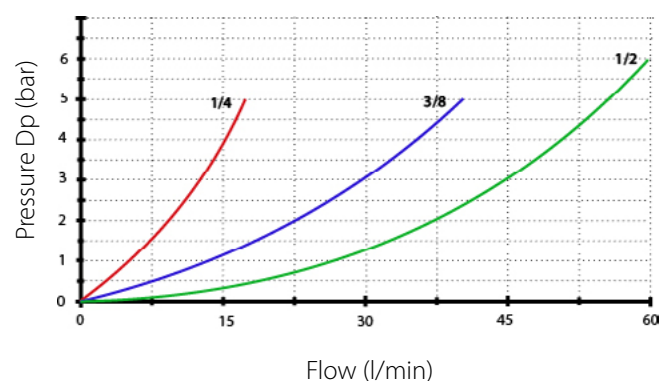

Standard code	Thread	L	L1	H	H1	S	ØF	Weight (kg)	Q max (l/min)
K-SHLV-14	1/4	52	34	40	8	30	6.5	0.30	20
K-SHLV-38	3/8	60	44	40	8	30	6.5	0.35	40
K-SHLV-12	1/2	70	50	60	10	30	8.5	0.66	60

## 3-WAYS MEDIUM PRESSURE MANUAL DIVERTER VALVES

### SPECIFICATIONS

Fluid viscosity:	15-250mm <sup>2</sup> /s
Filtration:	ISO 4406
Fluid temperature:	-20°C + 80°C
Ambient temperature:	-20°C + 50°C

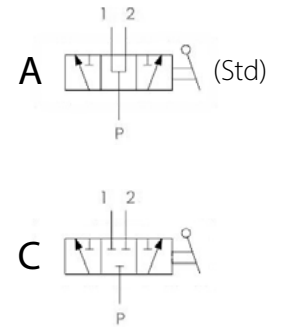

### DIMENSIONS (mm)

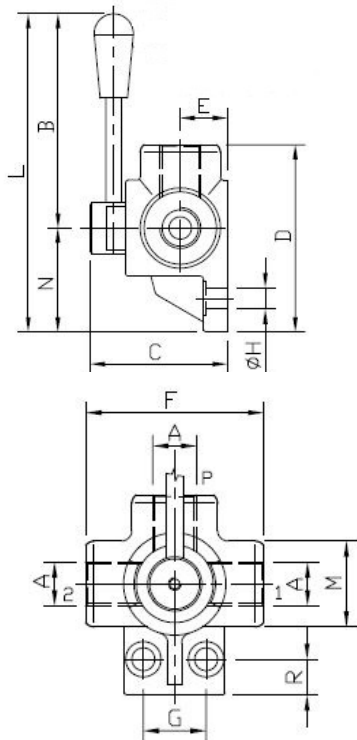

### PERFORMANCE

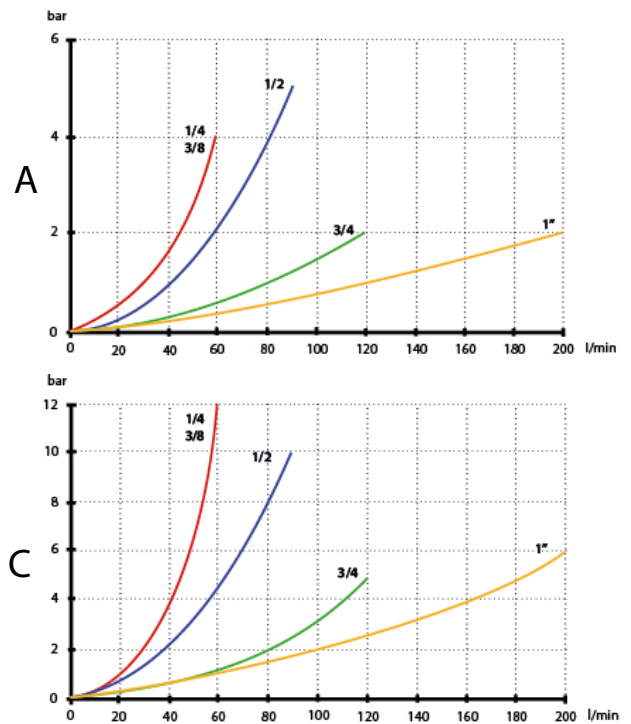

Standard code	Thread	Func	B	C	D	E	F	G	H	L	M	N	R	Q max (l/min)	Max Pres	kg
DDF3140-A	1/4	A/C	128	62	78.5	21	73	24	8.5	169	35	42	11	40	315	0.95
DDF3380-A	3/8	A/C	128	62	78.5	21	73	24	8.5	169	35	42	11	60	315	0.89
DDF3120-A	1/2	A/C	128	70	96	25	85	30	11	182	42	53	17	90	280	1.45
DDF3340-A	3/4	A/C	125	80	100	28	91	32	11	180	47	54	13	120	250	1.82
DDF3100-A	1"	A/C	140	90	113	32.5	98	32	11	207	56	64	14	200	220	2.50

## 6-WAYS MEDIUM PRESSURE MANUAL DIVERTER VALVES

### SPECIFICATIONS

Fluid viscosity:	15-250mm <sup>2</sup> /s
Filtration:	ISO 4406
Fluid temperature:	-20°C + 80°C
Ambient temperature:	-20°C + 50°C

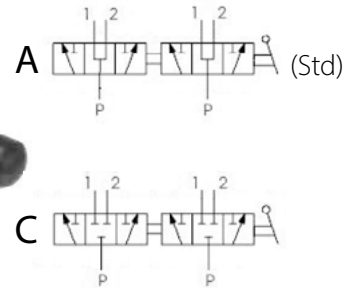

### DIMENSIONS (mm)

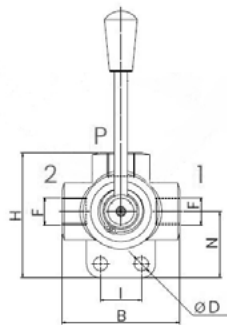
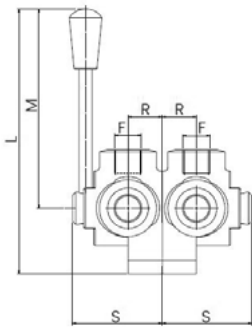

### PERFORMANCE

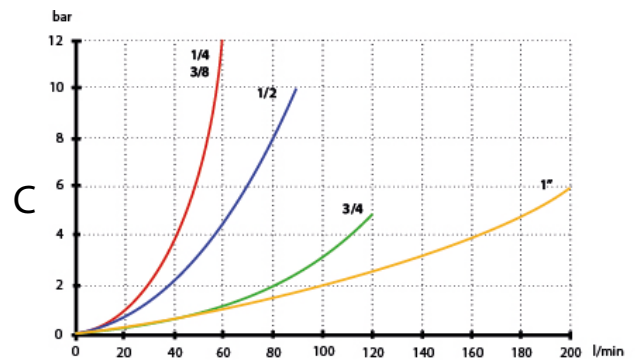
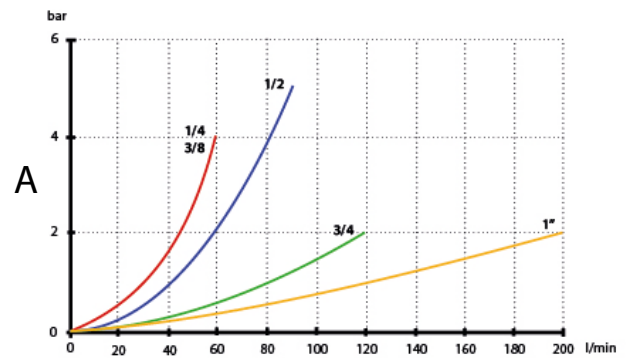

Standard code	Thread	Func	B	H	L	D	I	M	N	S	R	Q max (l/min)	Max Pres	kg
DDF6140-A	1/4	A/C	70	75.5	155.5	8.5	25	115	32	57	21	60+60	350	1.5
DDF6380-A	3/8	A/C	70	75.5	155.5	8.5	25	115	32	57	21	60+60	350	1.5
DDF6120-A	1/2	A/C	80	86	161	8.5	32	115	35	63	24	90+90	350	2.3
DDF6340-A	3/4	A/C	90	98.5	168.5	10.5	32	115	42	67	26	120+120	350	3.5
DDF6100-A	1"	A/C	98	110	176.5	10.5	32	115	50	77	31	200+200	300	5.3

## 3-WAYS HIGH PRESSURE MANUAL DIVERTER VALVES

### SPECIFICATIONS

Fluid viscosity:	15-250mm <sup>2</sup> /s
Filtration:	ISO 4406
Fluid temperature:	-20°C + 80°C
Ambient temperature:	-20°C + 50°C

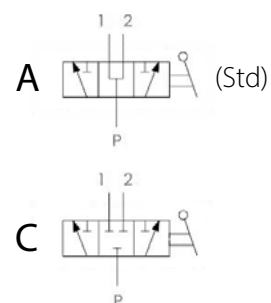

### DIMENSIONS (mm)

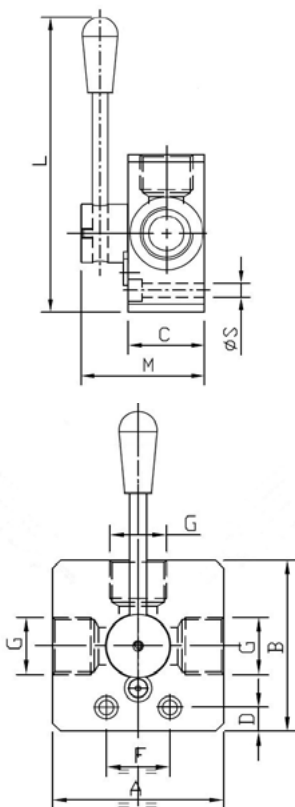

### PERFORMANCE

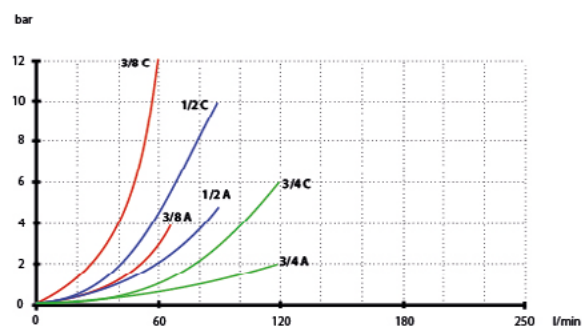

Standard code	Thread	Func	A	B	C	D	F	L	M	S	Q max (l/min)	Max Pres	kg
DDFA3140-A	1/4	A/C	60	60	40	10.5	30	167	68	8.5	50	400	1.10
DDFA3380-A	3/8	A/C	60	60	40	10.5	30	167	68	8.5	60	400	1.10
DDFA3120-A	1/2	A/C	60	60	40	10.5	30	167	68	8.5	90	400	1.05
DDFA3340-A	3/4	A/C	80	80	40	14	32	177	68	8.5	120	400	1.75

## DIRECTIONAL VALVES 3/8 210 BAR (315 BAR WITH DRAIN)

### SPECIFICATIONS

Fluid viscosity:	-2.8 +500 mm <sup>2</sup> /s
Fluid temperature:	-20°C + 80°C
Ambient temperature:	-20°C + 50°C
Max. operating pressure:	210 Bar
Weight:	3.1
Max. flow (l/min):	50

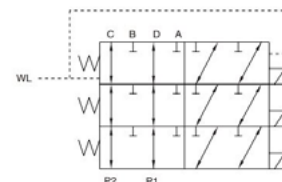
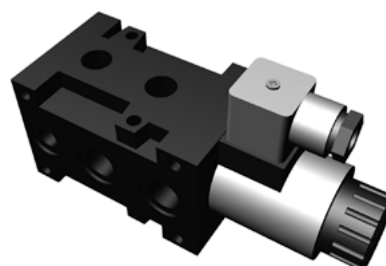

### DIMENSIONS (mm)

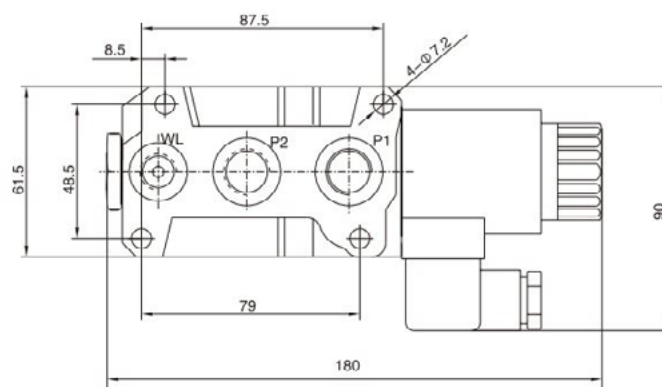
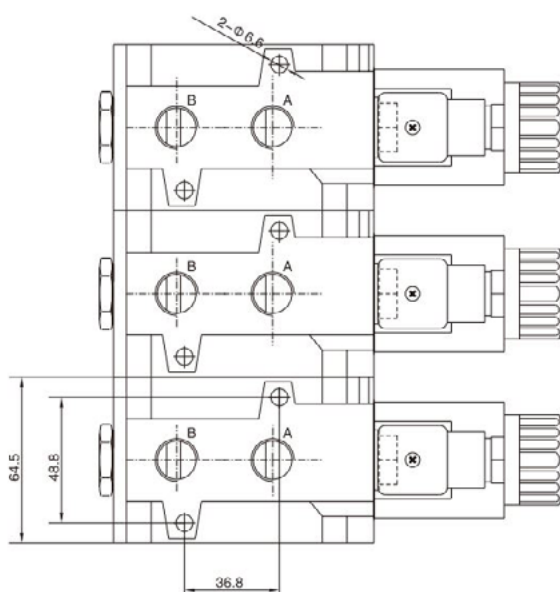

Standard code	Thread	Element Number	Voltage
VNK-6/2-6-3/8-1	3/8	1	12 dc
VNK-6/2-6-3/8-2	3/8	2	12 dc
VNK-6/2-6-3/8-3	3/8	3	12 dc
VNK-6/2-6-3/8-4	3/8	4	12 dc
VNK-6/2-6-3/8-5	3/8	5	12 dc
VNK-6/2-6-3/8-1	3/8	1	24 dc
VNK-6/2-6-3/8-2	3/8	2	24 dc
VNK-6/2-6-3/8-3	3/8	3	24 dc
VNK-6/2-6-3/8-4	3/8	4	24 dc
VNK-6/2-6-3/8-5	3/8	5	24 dc

## VINCKE DIRECTIONAL VALVES 1/2 210 BAR

### SPECIFICATIONS

Fluid viscosity:	-2.8 +500 mm <sup>2</sup> /s
Fluid temperature:	-20°C + 80°C
Ambient temperature:	-20°C + 50°C
Working pressure:	21 MPa
Weight:	5
Max. flow (l/min):	60

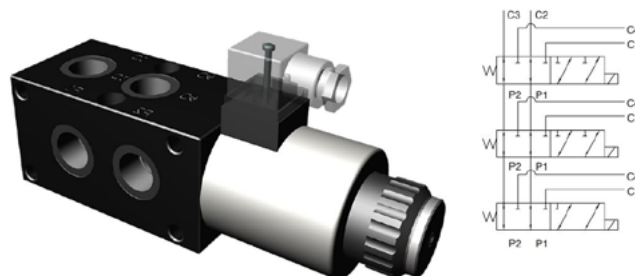

### DIMENSIONS (mm)

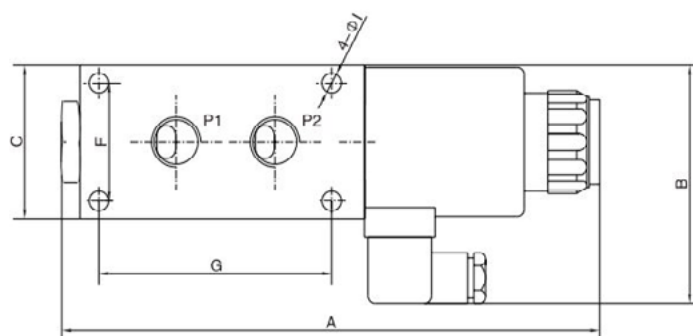
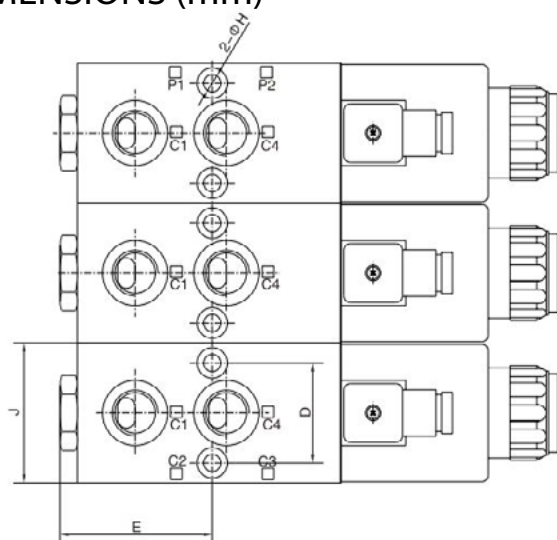

A	B	C	D	E	F	G	H	I	J
229	100.6	65	46	70	50	99	8	8.4	65

Standard code	Thread	Element Number	Voltage
SW 6/2-G-12dc-1	1/2	1	12 dc
SW 6/2-G-12dc-2	1/2	2	12 dc
SW 6/2-G-12dc-3	1/2	3	12 dc
SW 6/2-G-24dc-1	1/2	1	24 dc
SW 6/2-G-24dc-2	1/2	2	24 dc
SW 6/2-G-24dc-3	1/2	3	24 dc

## END STROKE

### SPECIFICATIONS

Fluid viscosity:	ISO 3448
Filtration:	ISO 4406
Fluid temperature:	-20°C + 90°C
Ambient temperature:	-20°C + 50°C
Max. operating pressure:	350 Bar
Standard seals:	NBR
External surfaces:	Zinc plated steel

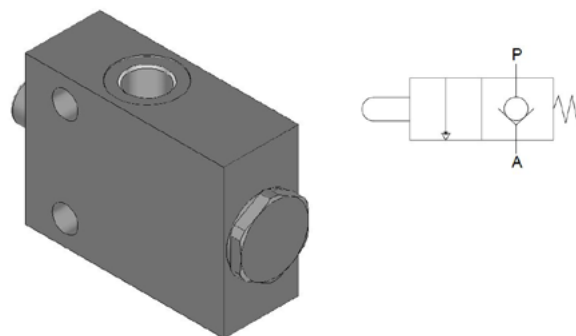

### DIMENSIONS (mm)

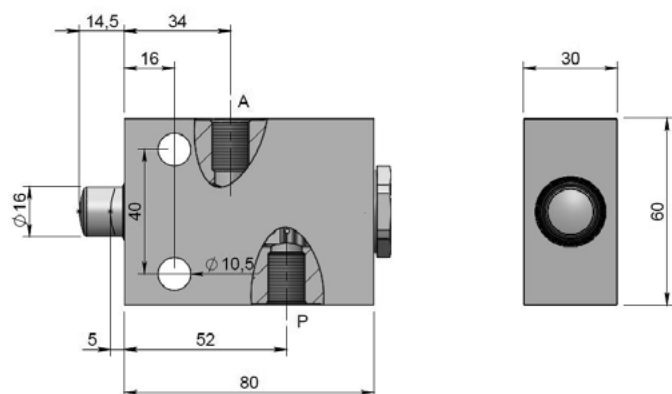

### PERFORMANCE

Oil viscosity 24 mm<sup>3</sup>/s (3,5 °E) - Temperature 50°C

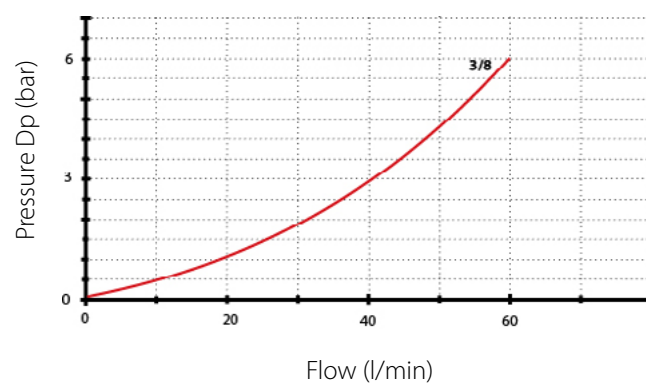

Standard code	Thread	Q max (l/min)	Max Pressure	Weight (kg)
K-ES-38	3/8	40	350	1.00

## RELIEF MOTOR VALVES VNKP/VNKR

### SPECIFICATIONS

Fluid viscosity:	ISO 3448
Filtration:	ISO 4406
Fluid temperature:	-20°C + 90°C
Ambient temperature:	-20°C + 50°C
Max. operating pressure:	350 Bar
Standard seals:	NBR
Manifold material:	Zinc plated steel

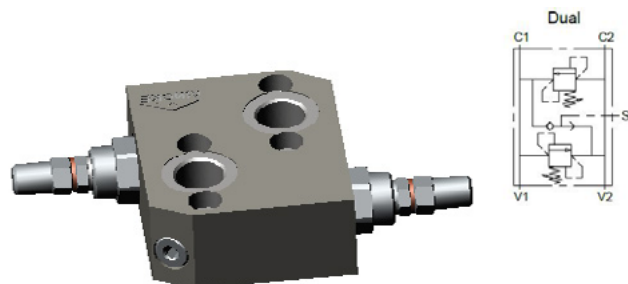

### DIMENSIONS (mm)

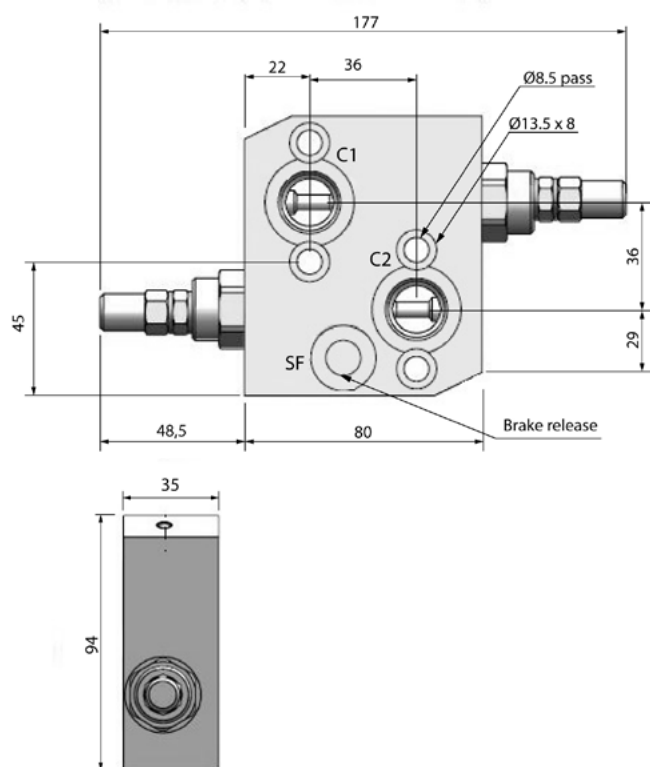

### PERFORMANCE

Oil viscosity 24 mm<sup>2</sup>/s (3,5 °E) - Temperature 50°C

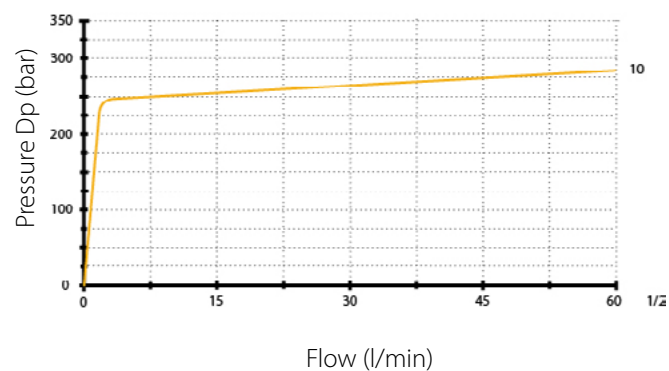

Std setting at 5 l/min

10 = 50 - 250 bar      130 bar

Standard code	Thread	Weight (kg)	Q max (l/min)
K-FPR-DRLVD	1/2	1.7	60

## MANUAL ROTARY DIRECTIONAL CONTROL MOTOR VALVES VNKP/VNKR

### SPECIFICATIONS

Max. flow	70L/min
Max. pressure	250 bar

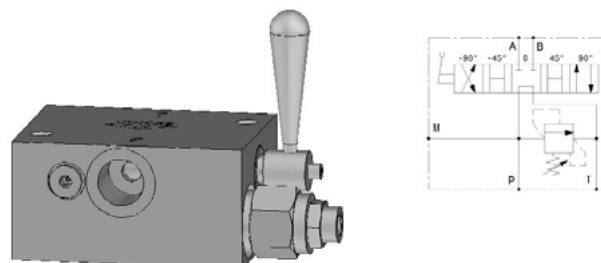

### DIMENSIONS (mm)

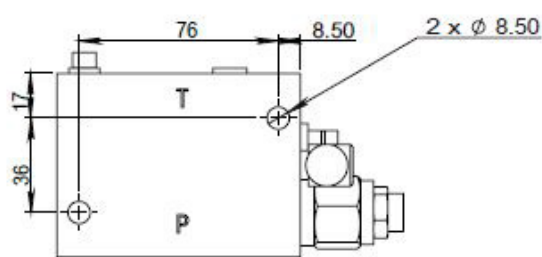
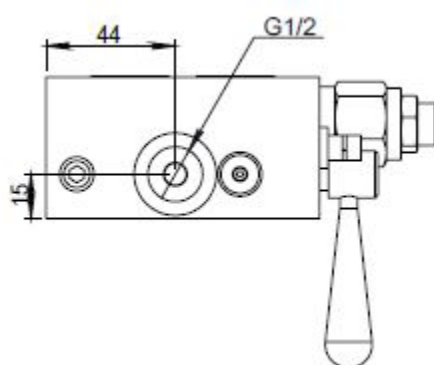
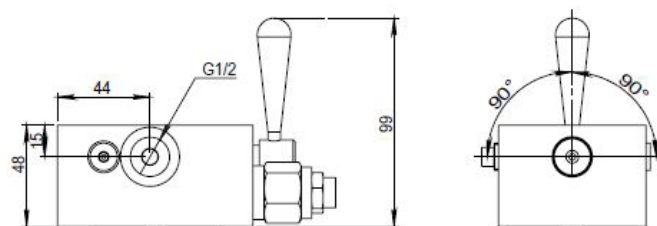
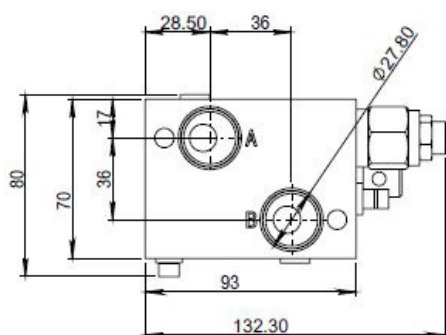

Standard code	Thread	Range	Body material
RMV-A-P-R-250-S	1/2	85-250	Zinc plated steel
RMV-A-P-R-250-B	1/2	85-250	brass

## SPOOL FLOW DIVIDERS

### SPECIFICATIONS

Fluid viscosity:	10-550mm <sup>2</sup> /s
Filtration:	ISO code 16/13
Fluid temperature:	-20°C + 90°C
Ambient temperature:	-20°C + 50°C
Standard seals:	NBR
External surfaces:	Zinc plated steel

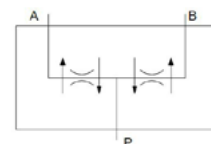

### DIMENSIONS (mm)

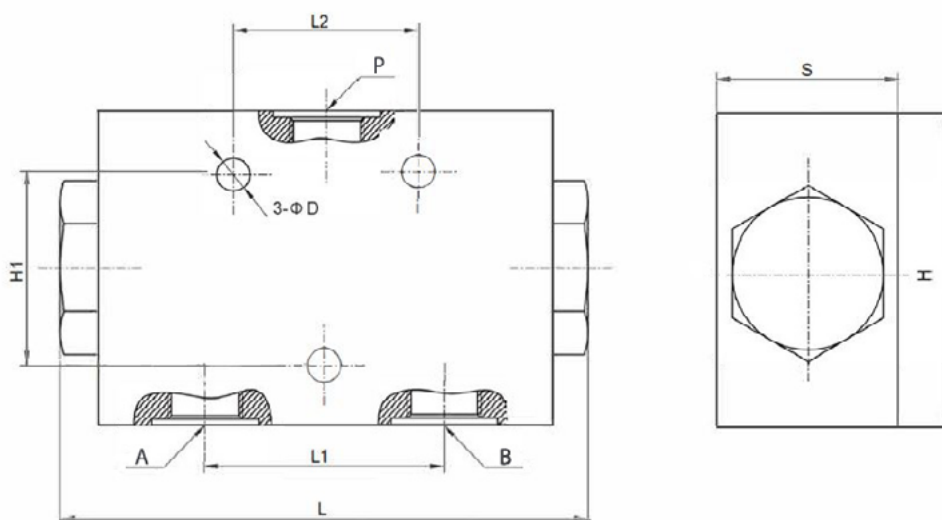

Standard code	Flow/Portata	P	A-B	L	L1	L2	H	H1	S	Max. Pressure	Weight (kg)
K-FDLV-6/10	6-10	3/8	3/8	117	53	40	70	45	40	250	2
K-FDLV-10/20	10-20	3/8	3/8	117	53	40	70	45	40	250	2
K-FDLV-25/40	25-40	1/2	3/8	117	53	40	70	45	40	250	2
K-FDLV-40/60	40-60	1/2	3/8	117	53	40	70	45	40	300	2
K-FDLV-60/80	60-80	1/2	3/8	117	53	40	70	45	40	300	2

# IN-LINE VALVES

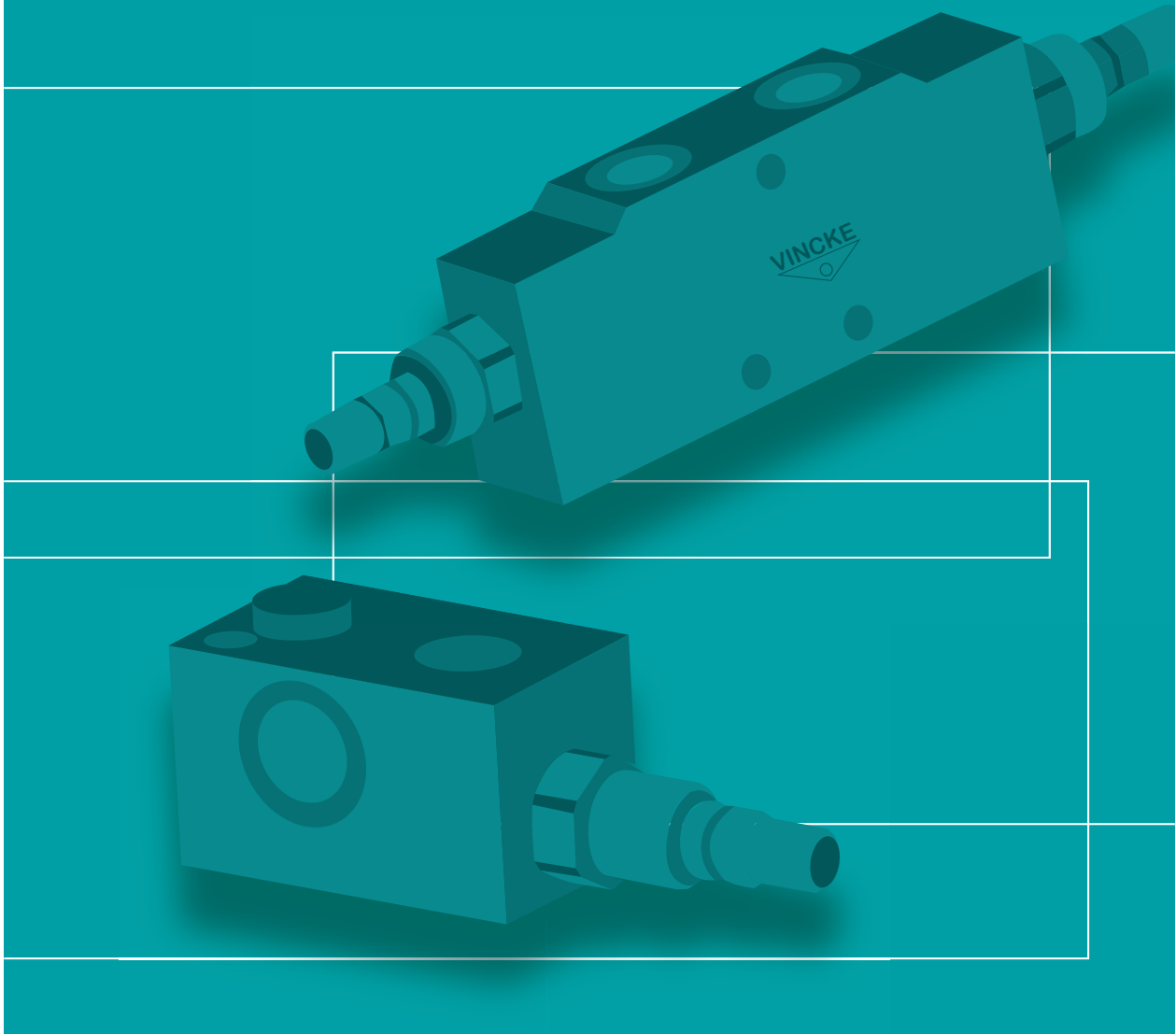

# VINCKE

Your Hydraulic Brand

